

mitsubishi

Mitsubishi
Programmable Controller

Transition of CPUs in MELSEC Redundant System Handbook

(Transition from Q4ARCPU to QnPRHCPU)

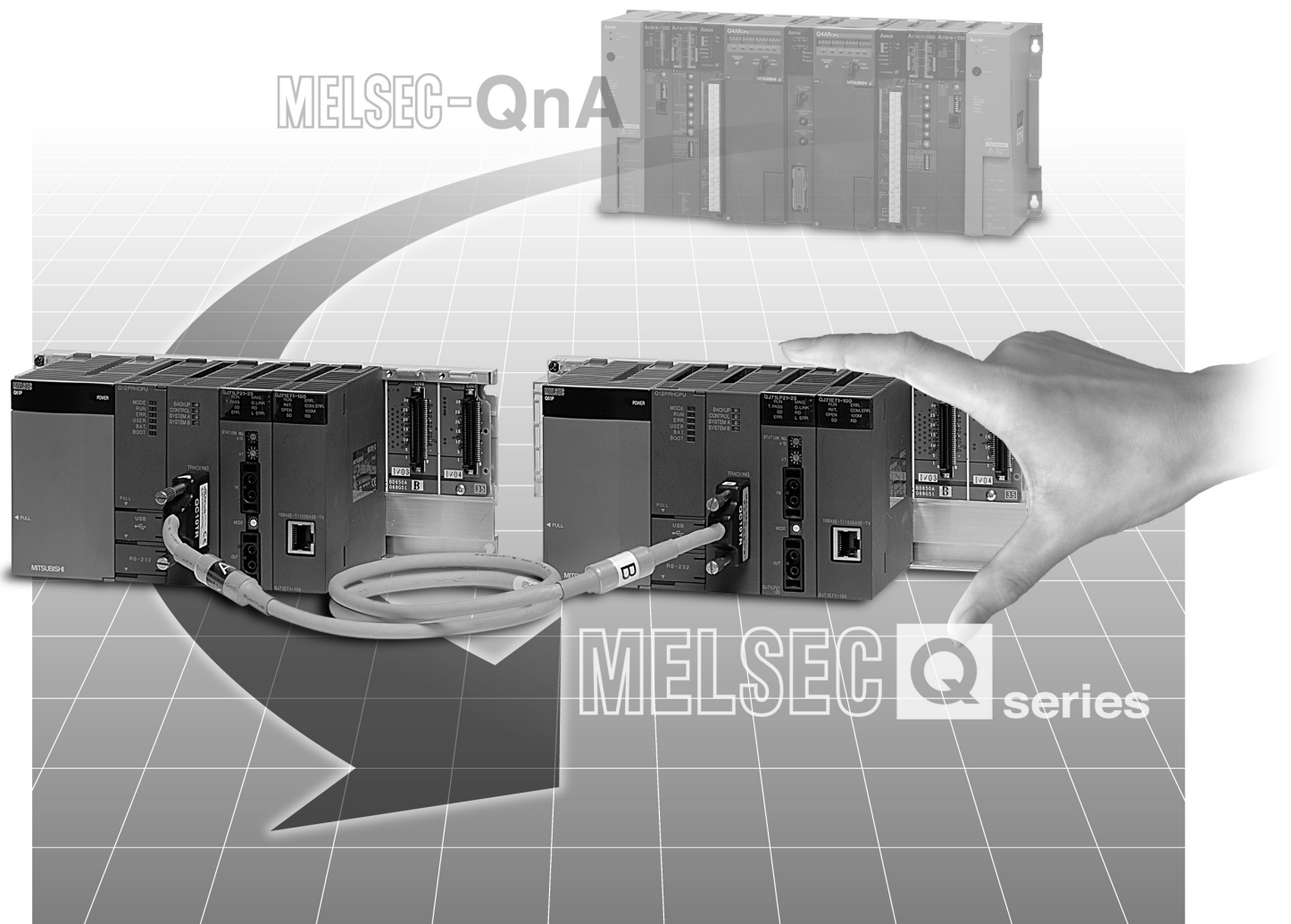

● SAFETY PRECAUTIONS ●

(Always read these instructions before using this equipment.)

Before using this product, please read this handbook and the relevant manuals introduced in this handbook carefully and pay full attention to safety to handle the product correctly.

In this manual, the safety instructions are ranked as "DANGER" and "CAUTION".



Indicates that incorrect handling may cause hazardous conditions, resulting in death or severe injury.

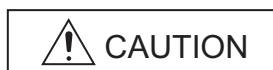

Indicates that incorrect handling may cause hazardous conditions, resulting in medium or slight personal injury or physical damage.

Note that the  CAUTION level may lead to a serious consequence according to the circumstances. Always follow the instructions of both levels because they are important to personal safety.

Please save this handbook to make it accessible when required and always forward it to the end user.

[Design Precautions]**! DANGER**

- Install a safety circuit external to the programmable controller that keeps the entire system safe even when there are problems with the external power supply or the programmable controller. Otherwise, trouble could result from erroneous output or erroneous operation.

(1) Outside the programmable controller, construct mechanical damage preventing interlock circuits such as emergency stop, protective circuits, positioning upper and lower limits switches and interlocking forward/reverse operations.

(2) When the programmable controller detects the following problems, it will stop calculation and turn off all output in the case of (a).

In the case of (b), it will hold or turn off all output according to the parameter setting.

	Q series module	A series module
(a) The power supply module has over current protection equipment and over voltage protection equipment.	Output OFF	Output OFF
(b) The CPU module self-diagnosis functions, such as the watchdog timer error, detect problems.	Hold or turn off all output according to the parameter setting.	Output OFF

In addition, all output will be turned on when there are problems that the programmable controller CPU cannot detect, such as in the I/O controller. Build a fail safe circuit exterior to the programmable controller that will make sure the equipment operates safely at such times.

Refer to "LOADING AND INSTALLATION" in QCPU User's Manual (Hardware Design, Maintenance and Inspection) for example fail safe circuits.

(3) Output could be left on or off when there is trouble in the outputs module relay or transistor. So build an external monitoring circuit that will monitor any single outputs that could cause serious trouble.

[Design Precautions] **DANGER**

- When overcurrent which exceeds the rating or caused by short-circuited load flows in the output module for a long time, it may cause smoke or fire. To prevent this, configure an external safety circuit, such as fuse.
- Build a circuit that turns on the external supply power when the programmable controller main module power is turned on.
If the external power supply is turned on first, it could result in erroneous output or erroneous operation.
- When there are communication problems with the data link, refer to the corresponding data link manual for the operating status of each station.
Not doing so could result in erroneous output or erroneous operation.
- When connecting a peripheral device to the CPU module or connecting a personal computer or the like to the intelligent function module to exercise control (data change) on the running programmable controller, configure up an interlock circuit in the sequence program to ensure that the whole system will always operate safely.
Also before exercising other control (program change, operating status change (status control)) on the running programmable controller, read the manual carefully and fully confirm safety.
Especially for the above control on the remote programmable controller from an external device, an immediate action may not be taken for programmable controller trouble due to a data communication fault.
In addition to configuring up the interlock circuit in the sequence program, corrective and other actions to be taken as a system for the occurrence of a data communication fault should be predetermined between the external device and programmable controller CPU.

 **CAUTION**

- Do not bunch the control wires or communication cables with the main circuit or power wires, or install them close to each other.
They should be installed 100 mm (3.94 inch) or more from each other.
Not doing so could result in noise that would cause erroneous operation.
- When controlling items like lamp load, heater or solenoid valve using an output module, large current (approximately ten times greater than that present in normal circumstances) may flow when the output is turned OFF to ON.
Take measures such as replacing the module with one having sufficient rated current.

[Installation Precautions]

CAUTION

- Use the programmable controller in an environment that meets the general specifications contained in QCPU User's Manual (Hardware Design, Maintenance and Inspection).
Using this programmable controller in an environment outside the range of the general specifications could result in electric shock, fire, erroneous operation, and damage to or deterioration of the product.
- While pressing the installation lever located at the bottom of module, insert the module fixing tab into the fixing hole in the base unit until it stops. Then, securely mount the module with the fixing hole as a supporting point.
Incorrect loading of the module can cause a malfunction, failure or drop.
When using the programmable controller in the environment of much vibration, tighten the module with a screw.
Tighten the screw in the specified torque range.
Undertightening can cause a drop, short circuit or malfunction.
Overtightening can cause a drop, short circuit or malfunction due to damage to the screw or module.
- When installing extension cables, be sure that the base unit and the extension module connectors are installed correctly.
After installation, check them for looseness.
Poor connections could cause an input or output failure.
- Securely load the memory card into the memory card loading connector.
After installation, check for lifting.
Poor connections could cause an operation fault.
- Completely turn off the external supply power used in the system before mounting or removing the module. Not doing so could result in damage to the product. Note that the module can be changed online (while power is on) in the system that uses the Redundant CPU module or on the MELSECNET/H remote I/O station.
Note that there are restrictions on the modules that can be changed online (while power is on), and each module has its predetermined changing procedure.
For details, refer to "System Configuration Cautions" in QnPRHCPU User's Manual (Redundant System).
- Do not directly touch the module's conductive parts or electronic components.
Touching the conductive parts could cause an operation failure or give damage to the module.

[Wiring Precautions]

DANGER

- Completely turn off the external supply power used in the system when installing or placing wiring. Not completely turning off all power could result in electric shock or damage to the product.
- When turning on the power supply or operating the module after installation or wiring work, be sure that the module's terminal covers are correctly attached. Not attaching the terminal cover could result in electric shock.

CAUTION

- Be sure to ground the FG terminals and LG terminals to the protective ground conductor. Not doing so could result in electric shock or erroneous operation.
- When wiring in the programmable controller, be sure that it is done correctly by checking the product's rated voltage and the terminal layout. Connecting a power supply that is different from the rating or incorrectly wiring the product could result in fire or damage.
- External connections shall be crimped or pressure welded with the specified tools, or correctly soldered. Imperfect connections could result in short circuit, fires, or erroneous operation.
- Tighten the terminal screws with the specified torque. If the terminal screws are loose, it could result in short circuits, fire, or erroneous operation. Tightening the terminal screws too far may cause damages to the screws and/or the module, resulting in fallout, short circuits, or malfunction.
- Be sure there are no foreign substances such as sawdust or wiring debris inside the module. Such debris could cause fires, damage, or erroneous operation.
- The module has an ingress prevention label on its top to prevent foreign matter, such as wire offcuts, from entering the module during wiring. Do not peel this label during wiring. Before starting system operation, be sure to peel this label because of heat dissipation.
- Install our programmable controller in a control panel for use. Wire the main power supply to the power supply module installed in a control panel through a distribution terminal block. Furthermore, the wiring and replacement of a power supply module have to be performed by a maintenance worker who acquainted with shock protection. (QCPU User's Manual (Hardware Design, Maintenance and Inspection)).

[Startup and Maintenance Precautions]

DANGER

- Do not touch the terminals while power is on. Doing so could cause shock or erroneous operation.
- Correctly connect the battery.
Also, do not charge, disassemble, heat, place in fire, short circuit, or solder the battery.
Mishandling of battery can cause overheating or cracks which could result in injury and fires.
- Switch off all phases of the external supply power used in the system when cleaning the module or retightening the terminal or module mounting screws.
Not doing so could result in electric shock. Undertightening of terminal screws can cause a short circuit or malfunction. Overtightening of screws can cause damages to the screws and/or the module, resulting in fallout, short circuits, or malfunction.

CAUTION

- The online operations conducted for the CPU module being operated, connecting the peripheral device (especially, when changing data or operation status), shall be conducted after the manual has been carefully read and a sufficient check of safety has been conducted.
Operation mistakes could cause damage or problems with of the module.
- Do not disassemble or modify the modules.
Doing so could cause trouble, erroneous operation, injury, or fire.
- Use any radio communication device such as a cellular phone or a PHS phone more than 25cm (9.85 inch) away in all directions of the programmable controller.
Not doing so can cause a malfunction.
- Completely turn off the external supply power used in the system before mounting or removing the module. Not doing so could result in damage to the product.
Note that the module can be changed online (while power is on) in the system that uses the redundant CPU module or on the MELSECNET/H remote I/O station.
Note that there are restrictions on the modules that can be changed online (while power is on), and each module has its predetermined changing procedure. For details, refer to "System Configuration Cautions" in QnPRHCPU User's Manual (Redundant System).
- Do not mount/remove the module onto/from the base unit or terminal block more than 50 times (IEC61131-2-compliant), after the first use of the product. Failure to do so may cause to malfunction.
- Do not drop or give an impact to the battery mounted to the module.
Doing so may damage the battery, causing the battery fluid to leak inside the battery.
If the battery is dropped or given an impact, dispose of it without using.
- Before touching the module, always touch grounded metal, etc. to discharge static electricity from human body, etc. Not doing so can cause the module to fail or malfunction.

[Disposal Precautions] **CAUTION**

- When disposing of this product, treat it as industrial waste.

[Transportation Precautions] **CAUTION**

- When transporting lithium batteries, make sure to treat them based on the transport regulations.
(Refer to QCPU User's Manual (Hardware Design, Maintenance and Inspection))

REVISIONS

* The handbook number is given on the bottom left of the back cover.

Print date	* Handbook number	Revision
Jan., 2008	L(NA)-08117ENG-A	First edition

Japanese Handbook Version L-08116-A

This handbook confers no industrial property rights or any rights of any other kind, nor does it confer any patent licenses. Mitsubishi Electric Corporation cannot be held responsible for any problems involving industrial property rights which may occur as a result of using the contents noted in this handbook.

CONTENTS

SAFETY PRECAUTIONS.....	A - 1
REVISIONS.....	A - 8
CONTENTS.....	A - 9

CHAPTER 1 INTRODUCTION **1 - 1 to 1 - 12**

1.1 Suggestions for Replacement from the Q4ARCPU to the QnPRHCPU	1 - 1
1.1.1 Features of QnPRHCPU.....	1 - 2
1.1.2 Precautions for replacement	1 - 12

CHAPTER 2 COMPARISON OF REDUNDANT SYSTEMS **2 - 1 to 2 - 3**

2.1 Comparison between Q4ARCPU and QnPRHCPU	2 - 1
---	-------

CHAPTER 3 REPLACEMENT OF REDUNDANT SYSTEM **3 - 1 to 3 - 6**

3.1 Alternative Models List for Redundant System	3 - 1
3.2 Performance Specifications Comparison between Q4ARCPU and QnPRHCPU	3 - 2
3.3 Functional Comparison between Q4ARCPU and QnPRHCPU.....	3 - 4

CHAPTER 4 CONFIGURATION OF REDUNDANT SYSTEM **4 - 1 to 4 - 31**

4.1 System Configuration	4 - 1
4.1.1 System configuration diagram	4 - 1
4.1.2 Precautions for replacement of redundant system	4 - 3
4.1.3 Restrictions on remote I/O station	4 - 8
4.1.4 I/O refresh delay time	4 - 8
4.1.5 Comparison between the FROM/TO instruction and REMFR/REMTO instruction.....	4 - 8
4.2 GOT Connection	4 - 9
4.3 External Output	4 - 10
4.4 Redundant System Operation Mode.....	4 - 11
4.4.1 Redundant system operation mode	4 - 11
4.4.2 Changing redundant system operation mode	4 - 12
4.5 Deciding Control System/Standby System at Simultaneous Power-ON	4 - 14
4.6 Operation Mode Setting at CPU Start-up	4 - 16
4.6.1 Operation mode for the QnPRHCPU.....	4 - 16
4.6.2 Operation settings screen for the QnPRHCPU.....	4 - 17
4.7 System Switching Method between Control System and Standby System	4 - 18
4.7.1 Comparison of system switching causes	4 - 18
4.7.2 Operation mode setting at CPU switching	4 - 18
4.7.3 User switching	4 - 19
4.7.4 System switching time	4 - 20
4.8 Output Hold Specification at Stop Error	4 - 21

4.8.1	Output mode at QnPRHCPU error.....	4 - 21
4.8.2	Output operation from remote I/O station during an error	4 - 21
4.8.3	Output mode setting during QnPRHCPU error.....	4 - 22
4.9	Tracking Redundant System	4 - 23
4.9.1	Tracking transfer setting data of the QnPRHCPU	4 - 24
4.9.2	Setting tracking data of the QnPRHCPU	4 - 25
4.9.3	Tracking transfer time	4 - 25
4.10	MELSECNET/10(H) Pairing Setting.....	4 - 26
4.11	MELSECNET/H Redundant Settings	4 - 28
4.12	Buffer Memory Batch Refresh.....	4 - 29
4.13	Programming Tool.....	4 - 30
4.14	Restrictions on Instructions	4 - 30
4.15	Compatibility of the Process (PID) Control Instructions	4 - 31

CHAPTER 5	SPECIAL RELAYS	5 - 1 to 5 - 9
------------------	-----------------------	-----------------------

CHAPTER 6	SPECIAL REGISTERS	6 - 1 to 6 - 8
------------------	--------------------------	-----------------------

APPENDICES	App - 1 to App - 3
-------------------	---------------------------

Appendix 1	Related Manuals.....	App - 1
Appendix 1.1	Transition from MELSEC-A/QnA (Large type) series to Q series handbook	App - 1
Appendix 1.2	Q4ARCPU.....	App - 1
Appendix 1.3	QnPRHCPU.....	App - 2

1 INTRODUCTION

1.1 Suggestions for Replacement from the Q4ARCPU to the QnPRHCPU

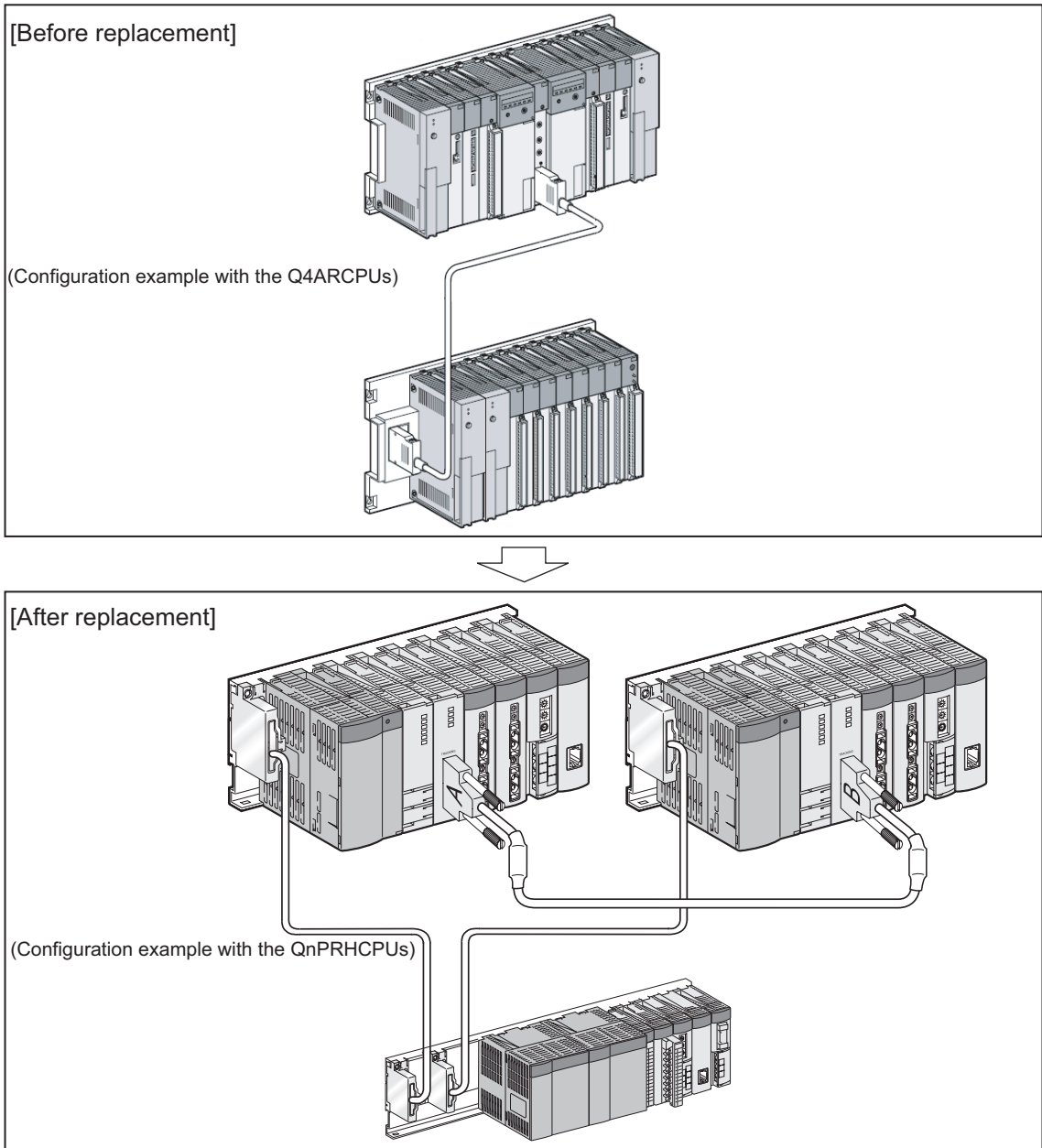

1.1.1 Features of QnPRHCPU

(1) Redundant configuration of basic system

As a redundant system consists two basic systems, i.e., two sets of CPU modules, power supply modules, main base units, network module, etc., one of the basic systems controls the whole system, while the other one performs backup.

Data of the CPU module performing control is transferred to the backup CPU module in order to make the data consistent. This enables the backup system to take over the redundant system control after the control system goes down and system switching occurs.

(Redundant configuration of basic system)

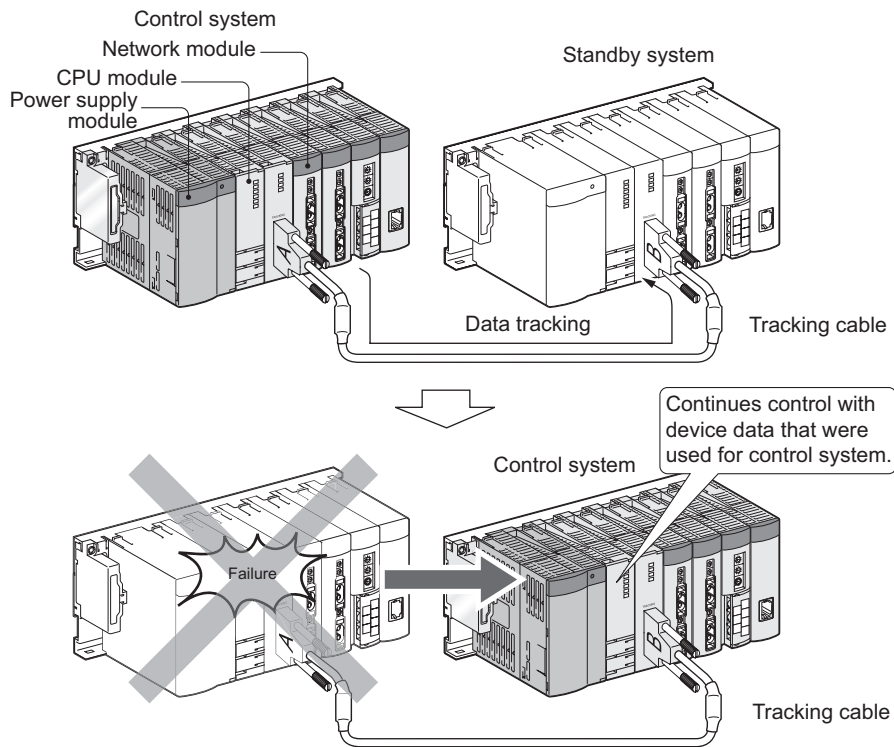

(2) Connection of extension base unit

In the redundant system where the Redundant CPUs whose first five digits of serial number is "09012" or higher is used in both systems, the extension base unit can be connected.

(System to which extension base unit is connected)

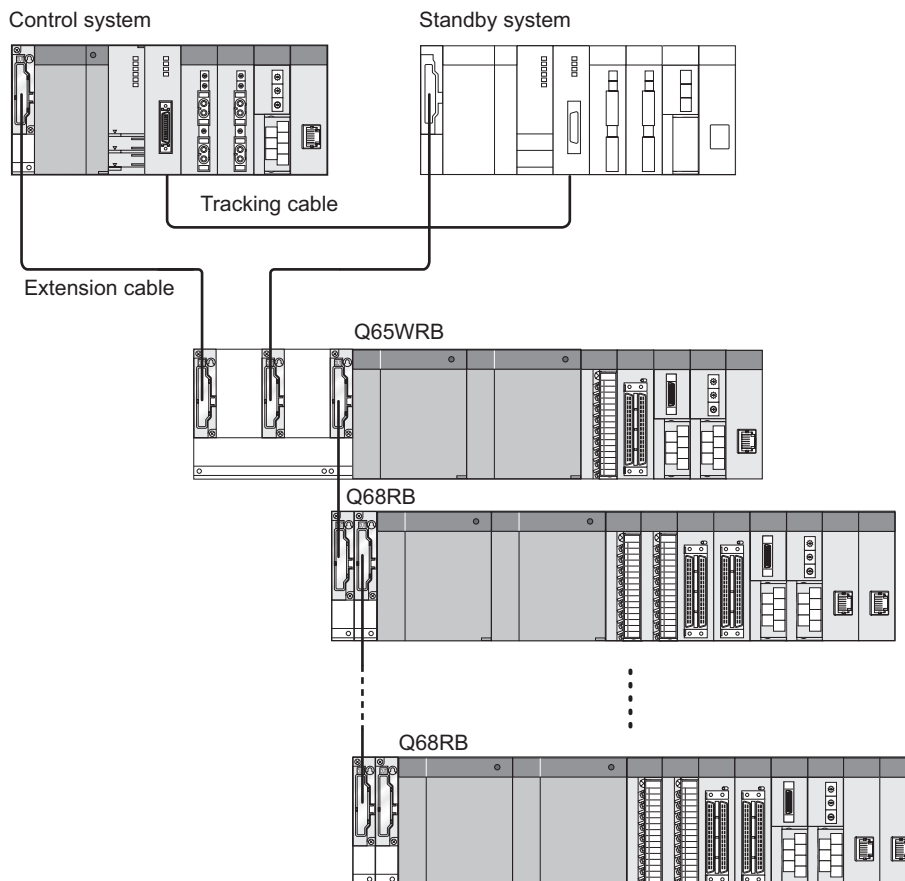

POINT

High-speed system bus of the MELSEC-Q series base unit allows to perform the following functions at high-speed.

- I/O refresh to all modules
- An access to intelligent function module (including auto refresh)
- Link refresh with network module

(3) Network configuration including redundant system

(a) MELSECNET/H PLC to PLC network and Ethernet

In the case of MELSECNET/H PLC to PLC network and Ethernet, control/standby system switching occurs and system control and network communication is continued even when a network module fails or when network cable disconnection is detected.

(System configuration for MELSECNET/H PLC to PLC network)

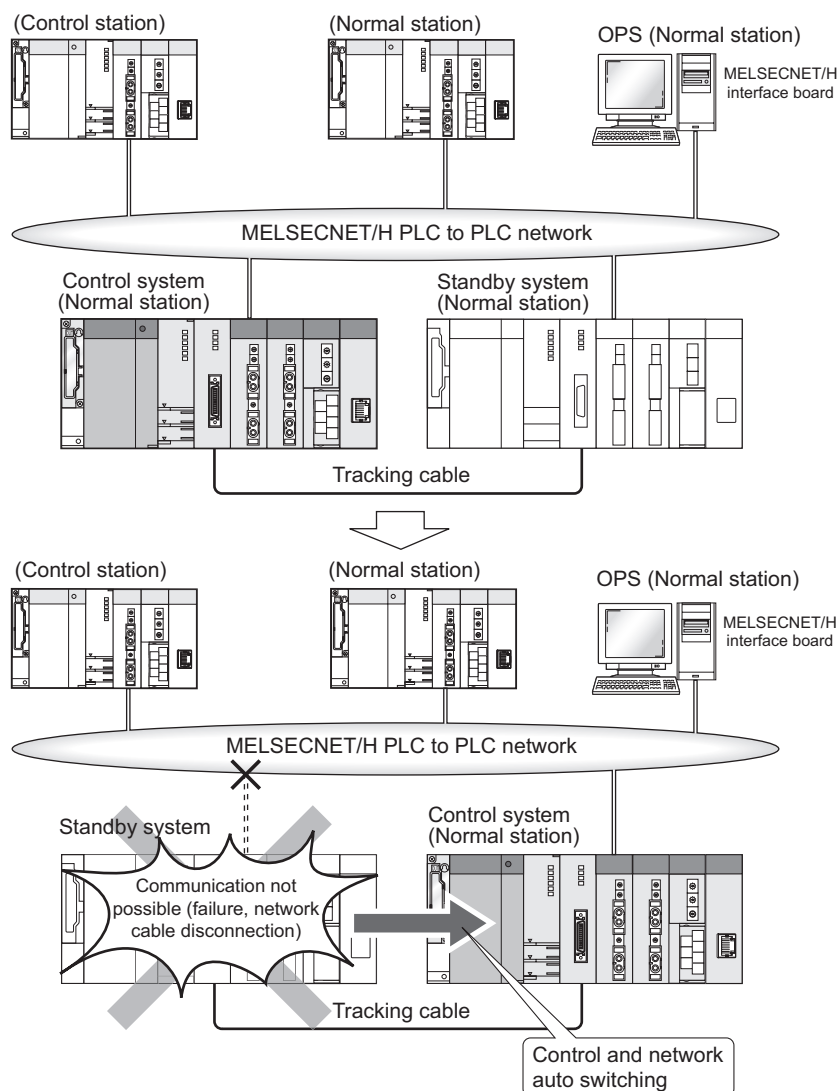

POINT

- 1) Switching systems at Ethernet communication error
 For the Q4ARCPUs, the systems do not switch even if an error occurs in Ethernet communications (Only the communication stops and the CPU module continues an operation.)
 For the QnPRHCPUs, the systems can be switched by parameter setting if an error occurs in Ethernet communications.
- 2) Identifying status of the Redundant CPUs (control system/standby system) during Ethernet communication
 For the Q4ARCPUs, the user must know whether the current control system is system A or system B, and understand the system (system A or system B) in communication with the other device using special relay (SM1516). For the QnPRHCPUs, if an error occurs in Ethernet communications, the communication is continued by control system follow (automatic follow)."

(b) MELSECNET/H remote I/O network

MELSECNET/H remote I/O stations can continue data link even when the control system and standby system switches.

(System configuration for MELSECNET/H remote I/O network)

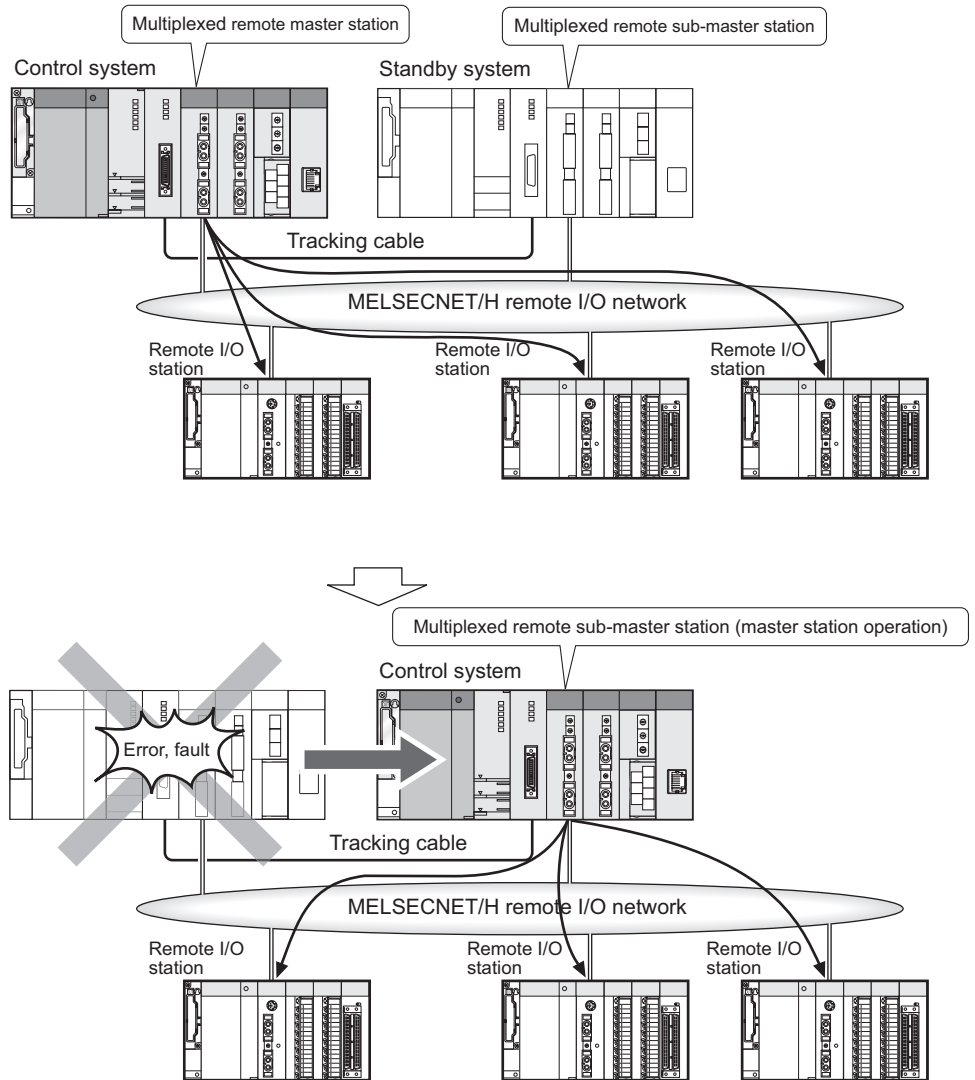

(c) PROFIBUS-DP

When the PROFIBUS-DP master module detects a fault or communication failure with slave stations, the both systems are switched so that the communications can be continued.

(System configuration for PROFIBUS-DP)

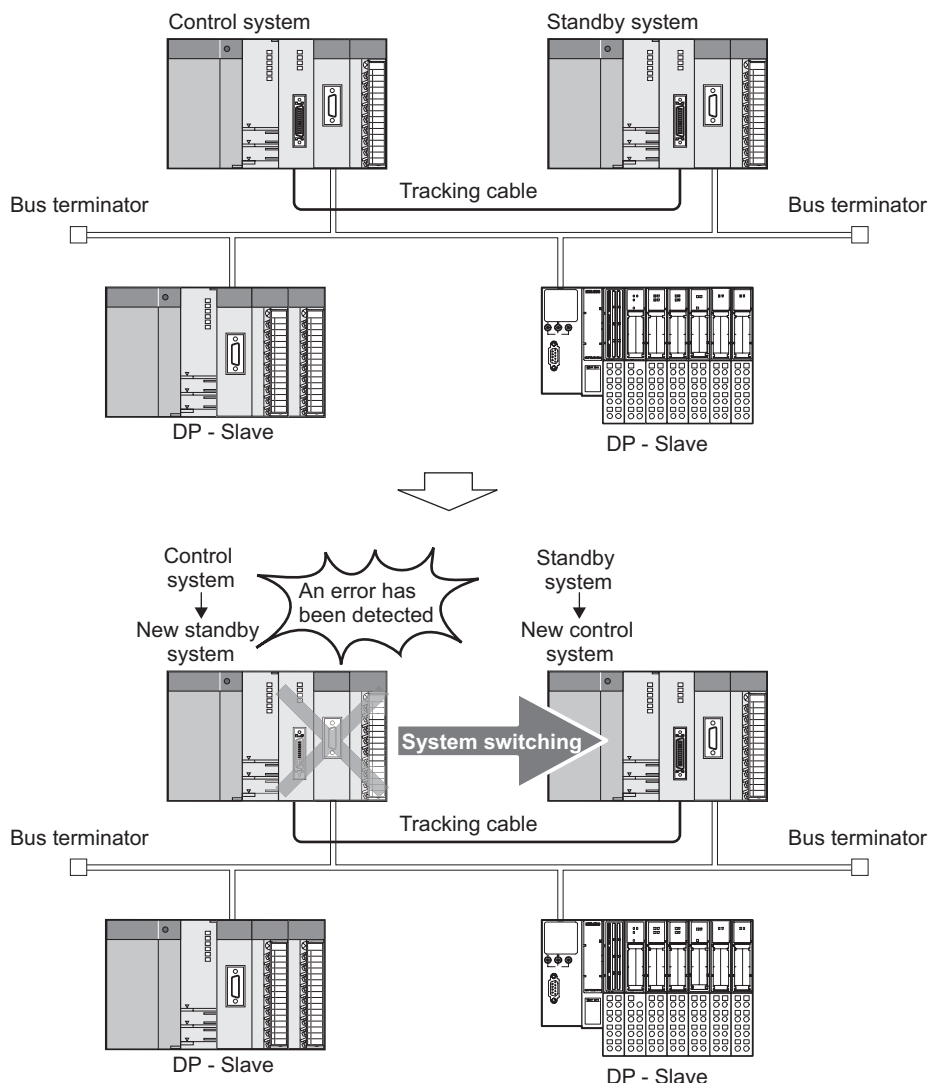

(4) Redundant system settings using parameters

Redundant system settings such as tracking settings, network pairing setting, etc. can be made easily in the parameter settings of GX Developer.

POINT

Starting the Redundant CPUs to which network parameters are set

- 1) When using the Q4ARCPUs, since parameters are written to system A and system B individually, the CPU module to which parameters of the control station on the MELSECNET/10 are written (system A or system B) must be started first.
- 2) When using the QnPRHCPUs, since common parameters are written to system A and system B, considering the system (system A, system B) is unnecessary. Both systems can be used as a start-up system.

(5) Writing parameters and programs to control system and standby system without the need to identify each system

Parameters and programs can be written into both of control system and standby system using GX Developer. There is no need to identify each system.

(Writing to the control system and standby system by Write to PLC)

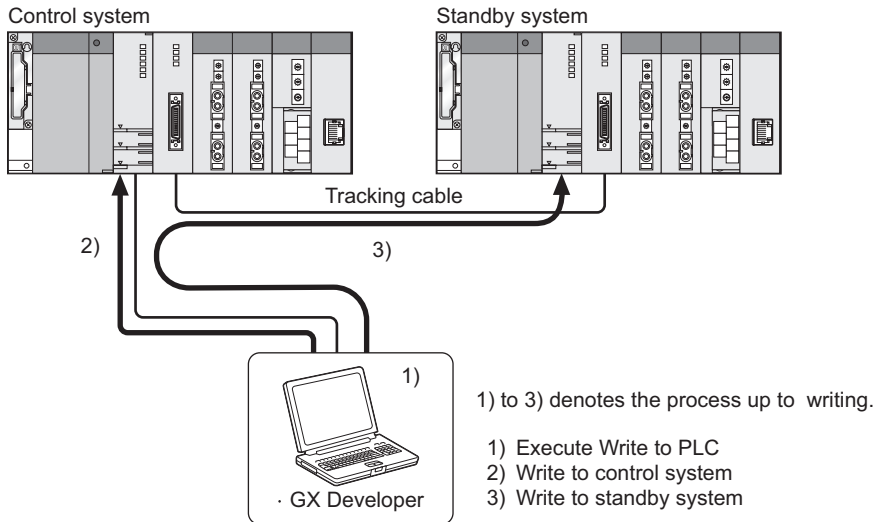

(6) Copy of parameters and programs from control system to standby system

After the CPU module is replaced in standby system, parameters and programs can be copied from the CPU module of control system to the new CPU module by executing the transfer command from GX Developer. This operation can also be done via special relays and special registers.

(Copying parameters and programs when CPU module is replaced)

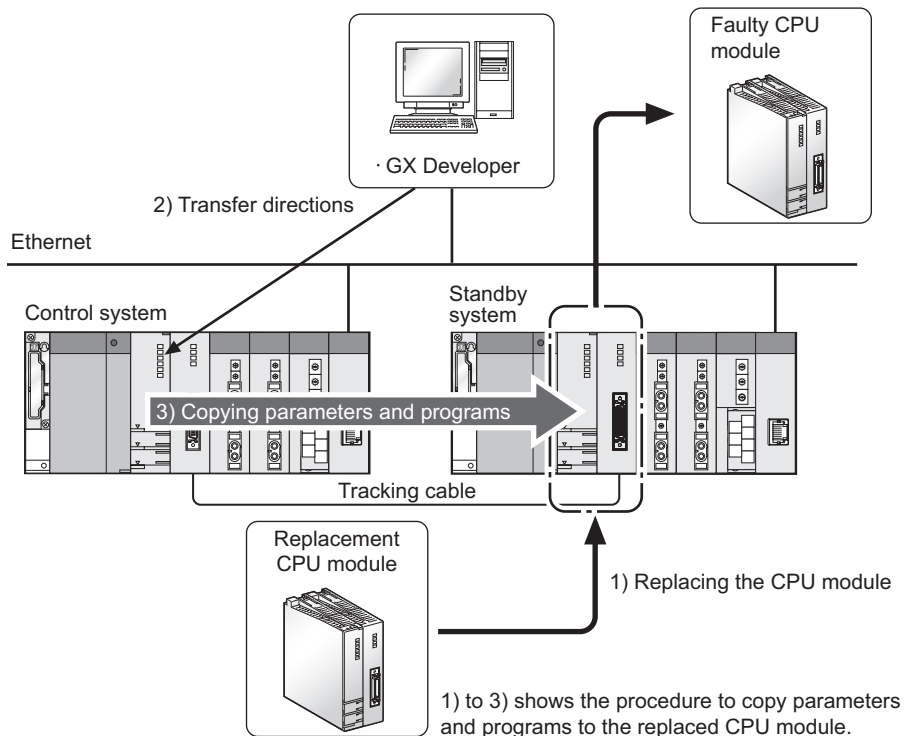

(7) Access to redundant system from host network

When accessing a redundant system from the host OPS via Ethernet, the host OPS can automatically identify and access the control system, if it has been specified as destination in advance.

(System configuration for Ethernet)

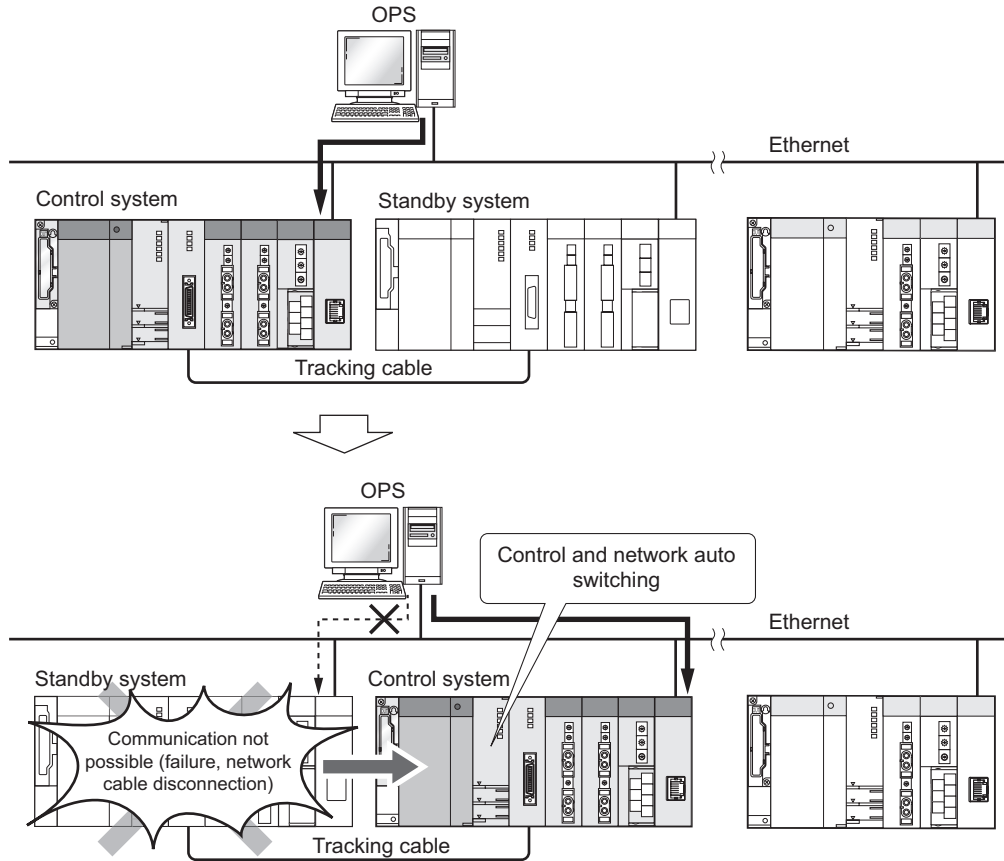

(8) Online module replacement

The redundant CPUs mounted on a main base unit, extension base unit or remote I/O station can be replaced online with GX Developer.

The module can be replaced without stopping the system, when it fails.

Note that a module mounted to the main base unit cannot be replaced online when the extension base unit is connected.

(Online module replacement of I/O module mounted on main base unit)

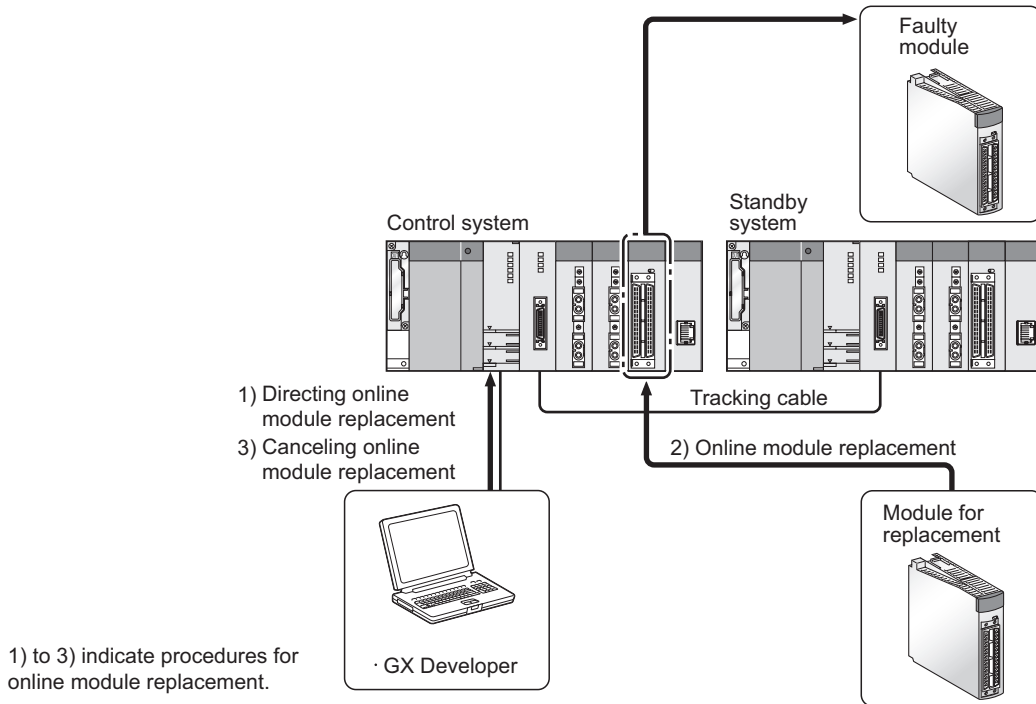

(Online module replacement on remote I/O station)

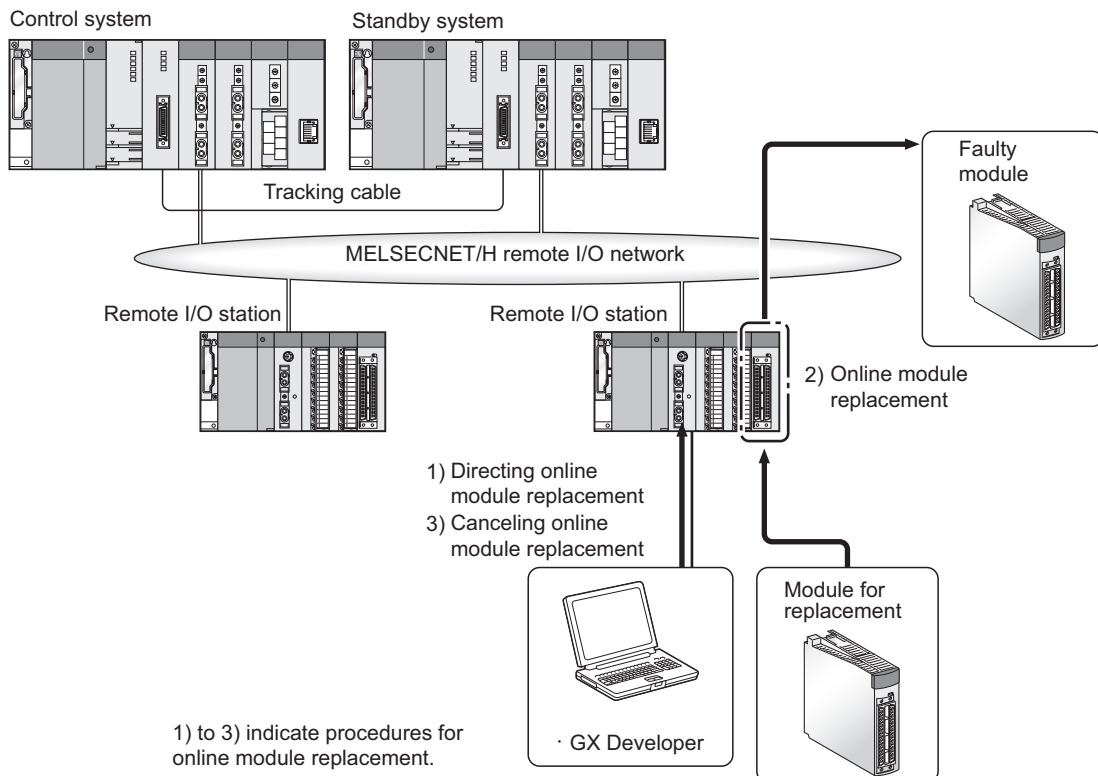

(9) System status can be monitored

The operating status of the whole redundant system can be monitored using the System Monitor of GX Developer.

(System Monitor on GX Developer)

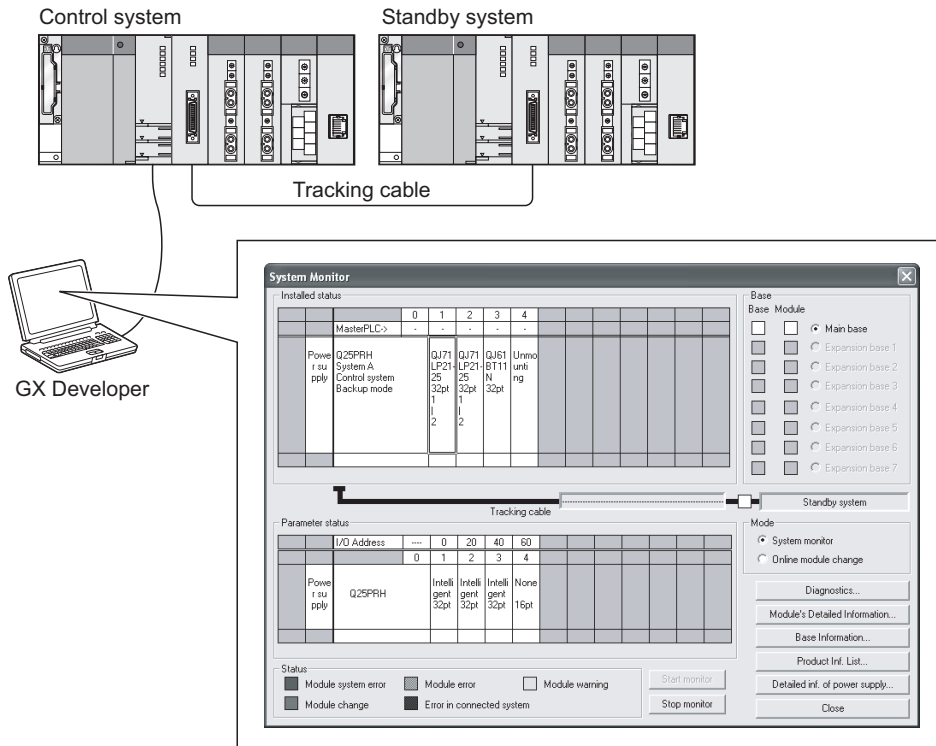

(10) Compact redundant system

The space of control panel can be saved, as Q-series modules (other than the CPU module, redundant power supply module, and tracking cable) are applicable.

(11) Flexible layout

The layout can be changed flexibly because the main base unit is divided into two units for the control system and standby system.

(Horizontal arrangement of control system and standby system)

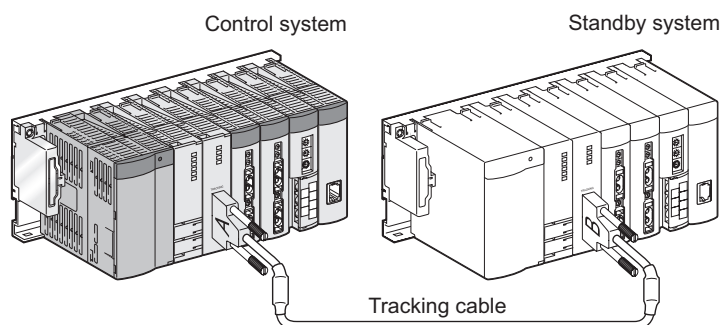

(Vertical arrangement of control system and standby system)

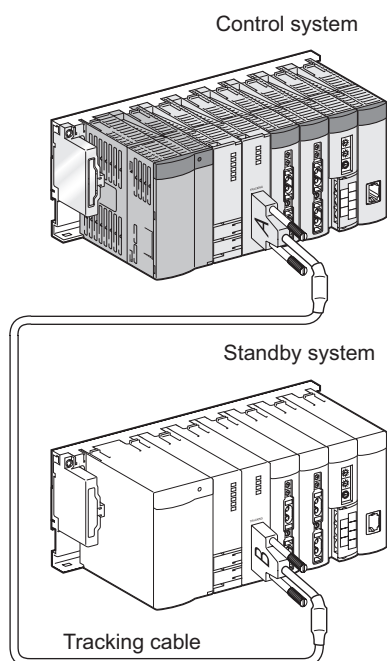

POINT

For details and precautions of redundant system with the QnPRHCPUs, refer to the following manual.

☞ QnPRHCPU User's Manual (Redundant System)

1.1.2 Precautions for replacement

- (a) Before replacing the redundant system from the Q4ARCPUs with the QnPRHCPU, always refer to the related manuals of the QnPRHCPU for checking the functions, specifications, and usage.
- (b) After replacement of the redundant system, always check operations of the entire system before actual operation.

2

COMPARISON OF REDUNDANT SYSTEMS

2.1 Comparison between Q4ARCPU and QnPRHCPU

The following table shows the comparison between the Q4ARCPU and QnPRHCPU redundant systems.

Item		QnPRHCPU redundant system	Q4ARCPU redundant system
Performance	Tracking transfer time	Internal device When 48k words is set	Internal device When 48k words is set
		Synchronized tracking mode: 41 ms * ¹	-
		Program Priority Mode: 21 ms * ¹	Batch transfer mode: 68.4 ms Repeat mode: 34.2 ms * ¹
	System switching time	* ²	300ms
System configuration	A series module	Not available	Available
	QnA series module	Not available	Available
	CC-Link auto refresh setting	Applicable (Can be set only for modules mounted on the extension base unit) Maximum 8 modules can be mounted on main base unit and extension base unit in total.	Not available (Performed using FROM/TO instruction)
	Maximum number of modules mountable on main/extension base unit	<<First five digits of serial number is 09011 or lower>> 11 modules (main base unit only) → Modules not used for redundant system are mounted to MELSECNET/H remote I/O station (Number of mountable modules on remote I/O station: 64 modules per station) <<First five digits of serial number is 09012 or higher>> maximum 63 modules (Main base unit + extension base unit: 7 stages)	58 modules (main base unit + extension base unit : 7 stages)

*1: Q4ARCPU repeat mode results in program priority mode on QnPRHCPU.

*2: Calculate the system switching time (Tsw) using the following expression.

For details, refer to "System Switching Time" in QnPRHCPU User's Manual (Redundant System).

$$T_{sw} = \alpha + T_{\alpha m} + T_{rc} \text{ (ms)}$$

- Tsw : System switching time (maximum value)
- Trc : Reflection time for tracking transfer data using the standby system CPU module
- T α m : MELSECNET/H, CC-Link, PROFIBUS-DP auto refresh time (T α m)
(Refer to the manual for the network module being used.)
- α : When the extension base unit is connected
 - Signal flow memory is not tracking-transferred: 31.5ms
 - Signal flow memory is tracking-transferred: 12.5ms
- When the extension base unit is not connected
 - Signal flow memory is not tracking-transferred: 20.5ms
 - Signal flow memory is tracking-transferred: 1.5ms

Item		QnPRHCPU redundant system	Q4ARCPU redundant system	
System configuration	System extension via extension base unit	<<First five digits of serial number is 09012 or higher>> Applicable (Extension base unit: Maximum 7 stages) <ul style="list-style-type: none"> The following modules cannot be mounted: Interrupt module, MELSECNET/H module, Ethernet module (function version: B or earlier), Web server module (first five digits of serial number is 09011 or lower), MES interface module (first five digits of serial number is 09011 or lower) For intelligent function modules, dedicated instructions and interrupt pointers are not usable. 	Available (Extension base unit: Maximum 7 stages)	
		<<First five digits of serial number is 09011 or lower>> Not available → Modules for the expanded system are mounted to MELSECNET/H remote I/O station. [Restrictions on mounting modules on remote I/O stations] <ul style="list-style-type: none"> FROM/TO instructions and intelligent function module devices (U□\VG□) are inapplicable. Use REMFR/REMTO for accessing. Or, in GX Configurator, configure the settings for intelligent function modules on remote I/O stations.*3 The following modules cannot be mounted to remote I/O stations: MELSECNET/H module, interrupt module, Web server module, and MES interface module. For Ethernet modules, dedicated instructions, interrupt pointers, e-mail function, communication by the fixed buffer, FTP server function, web server function is not usable. For intelligent function modules other than the above, dedicated instructions and interrupt pointers are not usable.		
	Single CPU system		Available (debug mode only)	Available
	GOT connection type *4	Bus connection	Not available	Available
		CPU direct connection	Available (Communication with the CPU module connected to the GOT only.)	Available
		Computer link connection	Not available	Available
		MELSECNET/H remote I/O station connection	Available	Not available
		CC-Link connection	Available	Available
MELSECNET/H PLC to PLC network connection		Available	Not available	
Ethernet connection	Available	Available		

*3: MELSECNET/H remote I/O stations have a limit for the maximum number of parameters that can be set with GX Configurator as intelligent function modules.

- The maximum number of parameter settings for initialization settings ≤ 512
- The maximum number of parameter settings for auto refresh setting ≤ 256

*4: For details of connection type of GOT, refer to Section 4.2.

Item		QnPRHCPU redundant system	Q4ARCPU redundant system	
System configuration	Mounting I/O module or network module on slot 0	Disabled (Slot 1 becomes I/O number "0") → Mount I/O modules and network modules on slots 1 and later.	Enabled	
	16-character LED indicator (self-diagnostic error information and comments are displayed.)	Not available → Self-diagnostic error information and comments, etc. can be confirmed using GX Developer.	Available	
	Manual system switching	System switching by the System switching instructions or redundant operation of GX Developer	System switching using switches of bus switching module (A6RAF)	
	Manual operation mode switching	Operation mode change by redundant operation of GX Developer	Operation mode change using switches of bus switching module (A6RAF)	
	External output at CPU module failure	Output using ERR. contact of power supply module	Output using CPU/ALARM/WDT contacts of system control module (AS92R)	
Programming tool	Q6PU	Not available	Available	
	SW□IVD-GPPQ	Not available	Available	
	GX Developer	Available (Refer to Section 4.13)	-	
	MX Links	Not available		
	MX Monitor	→ Substituted with MX Component. (PC-side application program correction necessary.)	Available	
	MX Chart			
	Connection port	RS-232, USB	RS422 (RS-232/RS-422 converter)	
Program	Restrictions on instructions	Restricted (refer to Section 4.14.)	-	
	Special relay	Some special relays are different. *5	-	
	Special register	Some special registers are different. *5	-	
	A series-compatible special relay (SM1000 and later)	Not available → Must be changed to a special relay available for QnPRHCPU *5	Available	
	A series-compatible special register (SD1000 and later)	Not available → Must be changed to a special register available for QnPRHCPU *5	Available	
	Number of steps	The number of steps for some instructions are different.	-	
	Low-speed execution type program	Not available	Available	
Debug function	Status latch	Not available	Available	
	Program trace	Not available	Available	
	Simulation	Not available → Use the function with GX Simulator.	Available	
	Step execution	Sequence program	Not available → Use the function with GX Simulator.	Available
		SFC program	Not available	

*5: For details, refer to the following manual.

 QCPU User's Manual (Hardware Settings, Maintenance and Inspection)

3

REPLACEMENT OF REDUNDANT SYSTEM

3.1 Alternative Models List for Redundant System

Discontinued model		Q series alternative model	Remarks (restrictions)
Product	Model	Model	
CPU module	Q4ARCPU	Q12PRHCPU Q25PRHCPU	1) I/O control: Refresh only→Refresh only 2) Processing speed (LD instruction): 0.075 μs→0.034 μs 3) PC MIX value: 3.8→10.3 4) Number of I/O points: 4096 points→4096 points 5) Program capacity : 124k steps→124k steps (Q12PRHCPU) 252k steps (Q25PRHCPU) 6) Number of file register points: 1014k points→1014k points 7) Number of extension stages: 7 stages→7 stages 8) Number of mountable memory cards: 2 →1 9) Memory card SRAM capacity MAX: 2M bytes×2 cards →2M bytes×1 card 10) I/O module connection method: Proximal I/O (extension cable) →Proximal I/O (extension cable) or MELSECNET/H remote I/O network
Main base unit	A32RB / A33RB	Q33B/Q35B/ Q38B/Q312B	1) Main base unit: 1 →2 (dedicated base unit→standard base unit) 2) Number of I/O slots: 2 slots→ (The number of slots on base unit used - 1)
Extension base unit	A68RB	Q65WRB	1) Connectable only to the first extension stage.
		Q68RB	1) Connectable to the second or later extension stages.
Power supply module	A61RP	Q64RP	No restrictions
	A67RP	Q63RP	Input power supply: 100VDC→24VDC
System control module	AS92R	(Unnecessary)	1) When using external output at CPU module failure of the AS92R, substitute ERR output of the Q series power supply module for it. 2) When using general-purpose input of the AS92SR, substitute Q series input module (QX40) for it.
Bus switching module	A6RAF	(Unnecessary)	The QnPRHCPU does not have bus switching module.
Tracking cable	-	QC10TR QC30TR	The QnPRHCPU requires tracking cable.
Remote I/O network	AJ71QLP21	QJ71LP21-25	Required to replace remote I/O station. (All remote I/O stations must be replaced by the Q series.)
	AJ71QBR11	QJ71BR11	
	AJ72QLP25	QJ72LP25-25	
	AJ72QBR15	QJ72BR15	

3.2 Performance Specifications Comparison between Q4ARCPU and QnPRHCPU

Item		Q4ARCPU	QnPRHCPU	Precautions for replacement
Control method		Stored program repetitive operation		-
I/O control mode		Refresh mode		-
Programming language		Relay symbol language, logic symbolic language, MELSAP3(SFC)	Relay symbol language, logic symbolic language, MELSAP3 (SFC), MELSAP-L, function block, structured text (ST) and FBD for process control	-
Processing speed (Sequence instruction) (μ s/step)	LD	0.075	0.034	-
	MOV	0.225	0.102	-
Constant scan (ms) (program start at constant intervals)		5 to 2000 (Setting available in 0.5ms unit.)	0.5 to 2000 (Setting available in 0.5ms unit.)	-
Memory card		Memory card type: SRAM, SRAM+E ² PROM, SRAM + Flash ROM Number of mountable cards: 2	Memory card type: SRAM, Flash, ATA Number of mountable cards: 1	Standard ROM and standard RAM for user memory are equipped with the Q series.
Program capacity	Number of steps (step)	Maximum 124k	Q12PRHCPU: 124K Q25PRHCPU: 252K	-
	Number of files	124	124	-
Number of I/O device points (point)		8192 (X/Y0 to 1FFF)		-
Number of I/O points (point)		4096 (X/Y0 to FFF)		-
Number of device points	Internal relay [M] (point)	8192 by default (M0 to 8191)		-
	Latch relay [L] (point)	8192 by default (L0 to 8191)		-
	Link relay [B] (point)	8192 by default (B0 to 1FFF)		-
	Timer [T] (point)	2048 by default (T0 to 2047) (Used for both high-speed timer and low-speed timer.) (changeable) The low- and high-speed timers are specified by the instructions. The measurement unit of the low- and high-speed timers is set up by parameters.		-
		Low-speed timer: 10 to 1000ms, 10ms unit, (100ms by default) High-speed timer: 1 to 100ms, 1ms unit, (10ms by default)	Low-speed timer: 1 to 1000ms, 1ms unit, (100ms by default) High-speed timer: 0.1 to 100ms, 0.1ms unit, (10ms by default)	-
	Retentive timer [ST] (point)	0 by default (Others are the same as Timer [T].)		-
	Counter [C] (point)	Normal counter: 1024 by default (C0 to 1023) Interrupt counter: Maximum 48	Normal counter: 1024 by default (C0 to 1023) Interrupt counter: Maximum 256	-
		(0 by default, set it with parameter.)		-
	Data register [D] (point)	12288 by default (D0 to 12287)		-
	Link register [W] (point)	8192 by default (W0 to 1FFF)		-
	Annunciator [F] (point)	2048 by default (F0 to 2047)		-
	Edge relay [V] (point)	2048 by default (V0 to 2047)		-
	File register [R•ZR] (point)	32768 (R0 to 32767) Maximum 1042432 points can be used by switching blocks.		-
1042432 (ZR0 to 1042431) Block switching is not required.		The number of points depends on storage location.		
Special link relay [SB] (point)	2048 by default (SB0 to 7FF)		-	
Special link register [SW] (point)	2048 by default (SW0 to 7FF)		-	

Item		Q4ARCPU	QnPRHCPU	Precautions for replacement
Number of device points	Step relay [S] (point)	8192 (S0 to 8191)		-
	Index register [Z] (point)	16 (Z0 to 15)		-
	Pointer [P] (point)	4096 (P0 to 4095) The usage range of file pointer/common pointer can be set with parameters.	4096 (P0 to 4095) The use ranges of the local pointers and common pointers can be set up by parameters.	-
	Interrupt pointer [I] (point)	48 (I0 to 47) The fixed scan interval of system interrupt pointer from I28 to I31 can be set with parameters (1 to 1000ms in units of 5ms)	256 (I0 to 255) The constant cyclic interval of system interrupt pointers I28 to I31 can be set up by parameters. (0.5 to 1000ms, in units of 5ms)	-
	Special relay [SM] (point)	2048 (SM0 to 2047)		-
	Special register [SD] (point)	2048 (SD0 to 2047)		-
	Function input [FX] (point)	5 (FX0 to 4)	16 (FX0 to F)	-
	Function output [FY] (point)	5 (FY0 to 4)	16 (FY0 to F)	-
	Function register [FD] (point)	5 (FD0 to 4)		-
Link direct device	Device for accessing the link device directly Specification format: J□□\X□□, J□□\Y□□, J□□\W□□, J□□\B□□, J□□\SW□□, J□□\SB□□			-
	Only for MELSECNET/10		Only for MELSECNET/H	-
Special function module direct device	Device for accessing the buffer memory of the intelligent function module directly Specification format: U□□\G□□			-
Latch (power failure compensation) range	L0 to 8191 (default) (Latch range can be set for B, F, V, T, ST, C, D, and W.)			-
Remote RUN/PAUSE contact	One point can be set up in X0 to 1FFF for each of RUN/PAUSE contact.			-
Clock function	Year, month, day, hour, minute, second, and day of the week (leap year automatically identified)			-
		Accuracy -2.3 to +4.4s (TYP.+1.8s)/d at 0°C Accuracy -1.1 to +4.4s (TYP.+2.2s)/d at 25°C Accuracy -9.6 to +2.7s (TYP.-2.4s)/d at 55°C	Accuracy -3.2 to +5.27s (TYP.+2.07s)/d at 0°C Accuracy -2.77 to +5.27s (TYP.+2.22s)/d at 25°C Accuracy -12.14 to +3.65s (TYP.-2.89s)/d at 55°C	-
5VDC internal current consumption (A)	1.4	0.89	-	
Weight (kg)	0.9	0.3	-	
External dimensions (mm (inch))	250×79.5×121 (mm) (9.84×3.13×4.76 (inch))	98×55.2×89.3 (mm) (3.86×2.17×3.52 (inch))		-

3.3 Functional Comparison between Q4ARCPU and QnPRHCPU

○: Available △: Although available, specifications such as setting method partially differs. ×: Not available

Function		Description	Q4ARCPU	QnPRHCPU	Remarks	
Redundant system function	GOT connection		○	△	The QnPRHCPU cannot be used in some connection types (refer to Section 4.2).	
	External output at CPU module failure		○	△	The QnPRHCPU differs in output terminal.	
	Redundant system operation mode		○	△	The QnPRHCPU differs in change method of operation mode (refer to Section 4.4).	
	Start mode at simultaneous power-ON		○	△	In QnPRHCPU redundant system, system A always becomes the control system. To start with previous control system, refer to Section 4.5.	
	Operation mode setting at CPU start-up		○	△	The QnPRHCPU differs in setting method (refer to Section 4.6).	
	Switching method between control system and standby system		○	△	The QnPRHCPU differs in system switching method (refer to Section 4.7).	
	Operation mode setting at system switching		○	△	The QnPRHCPU supports the hot start mode only. To start with status equivalent to the initial start mode (device clear), clear the devices using the FMOV instruction in SM1518 contact.	
	Identification check for both systems		○	○	-	
	Output hold at stop error		○	△	The QnPRHCPU differs in setting method (refer to Section 4.8).	
	Redundant tracking		○	△	The QnPRHCPU differs in setting method (refer to Section 4.9).	
	Online operation from peripheral	Online program change for redundancy	When writing data to the control system CPU module online, they are also written to the same program file in standby system CPU module.	○	○	-
	MELSECNET /10(H)	Pairing setting	Sets the combination of networks to configure redundant system.	○	△	For the QnPRHCPU, set this with parameters (refer to Section 4.10).
		Mode setting (redundant settings)	Sets the operation mode of network module.	○	△	For the QnPRHCPU, set this with parameters (refer to Section 4.11).
	Buffer memory auto refresh		Each refresh method for intelligent function modules	○	△	For the QnPRHCPU, set this with GX Configurator compatible with intelligent function module (refer to Section 4.12).

○: Available △: Although available, specifications such as setting method partially differs. ×: Not available

Function		Description	Q4ARCPU	QnPRHCPU	Remarks	
Program	Programming tool	Peripheral software package to create programs and set parameters of CPU module	○	△	The QnPRHCPU differs in programming tool and connection type (refer to Section 4.13).	
	Instruction	Can use instructions such as the Useful instruction.	○	△	The QnPRHCPU has some unsupported instructions (refer to Sections 4.14 and 4.15).	
	Low-speed execution	A program that is executed during spare time of a scan, separately from the main program	○	×	The QnPRHCPU does not have this function.	
	Special relay/special register	Stores information on the system and diagnostic result of CPU module.	○	△	The QnPRHCPU partially differs in description (refer to Chapters 5 and 6).	
	LED indication instruction	Displays characters on LED indicator.	○	×	Consider installing external indicator since the QnPRHCPU does not have the LED indication function.	
Debug function	Monitor function	Reads the status of programs and devices from CPU module to a peripheral.	○	○	-	
	Online program change	Writes a program from a peripheral while the CPU module is in RUN.	○	○	-	
	Execution time measurement	Program list monitor	Displays the processing time of a program being executed on a peripheral.	○	○	-
		Interrupt program list monitor	Displays the number of executions of an interrupt program on a peripheral.	○	○	-
		Scan time measurement	Measures the execution time of any given range in a program being executed by the CPU module.	○	○	-
	Sampling trace function	Continually collects the specified device data in CPU module at specified timing.	○	○	-	
	Status latch function	Collects the device data at specified timing.	○	×	The QnPRHCPU does not have this function.	
	Step run	Step execution	Executes a program by a step.	○	×	The QnPRHCPU does not have the step run function. Consider debugging a program with GX Simulator.
		Partial execution	Executes only the specified part in a program.	○	×	
		Skip execution	Executes a program with skipping specified part.	○	×	
Program trace function	Collects the program execution status.	○	×	The QnPRHCPU does not have this function.		
Simulation function	Simulates a program with I/O module and intelligent function module disconnected.	○	×	The QnPRHCPU does not have this function.		
Maintenance function	Watchdog timer	Watches for operation delay due to CPU module hardware or program error.	○	○	-	
	Self-diagnostics function	The CPU module itself diagnoses for errors.	○	○	-	
	Error history	Stores the diagnostic results in a memory as error history.	○	○	-	
	System protection	Sets whether to allow reading from/writing to files in CPU module.	○	○	-	
	Keyword registration	Disables a peripheral to operate CPU module memory.	○	○	-	
	Online I/O module replacement	Allows replacement of I/O modules while CPU module is in RUN.	○	△	The QnPRHCPU differs in operation. Refer to Q Corresponding MELSECNET/H Network System Reference Manual (Remote I/O network).	
	System display	Monitors system configuration on a peripheral.	○	○	-	
	LED indicator	LED indication	Indicates the operating status of CPU module.	○	○	-
Indication of LED indicator		Displays a message in case of an error.	○	×	Consider installing external indicator since the QnPRHCPU does not have the LED indication function.	

○: Available △: Although available, specifications such as setting method partially differs. ×: Not available

Function		Description	Q4ARCPU	QnPRHCPU	Remarks	
Other functions	Constant scan	Executes a program at fixed intervals regardless of the program scan time.	○	○	-	
	Latch function	Retains device data at power-OFF or reset operation.	○	○	-	
	Output status setting when switching from STOP to RUN	Sets the status of output Y when the CPU module is switched from STOP to RUN (Re-output of the outputs before STOP/output after operation).	○	○	-	
	Clock function	Runs the internal clock of CPU module.	○	○	-	
	Remote operation	Remote RUN/STOP	Operates/stops CPU module by remote control.	○	○	-
		Remote STEP-RUN	Performs a step operation to CPU module by remote control.	○	×	The QnPRHCPU does not have the STEP-RUN function.
		Remote PAUSE	Suspends CPU module operation by remote control.	○	○	-
		Remote RESET	Resets CPU module by remote control.	○	○	-
Remote latch clear		Clears CPU module latch data by remote control.	○	○	-	
Module access interval time read	Monitors the access intervals for special function modules, network modules, and peripherals (time taken from the acceptance of CPU module access to the acceptance of the next access).	○	○	-		

For details of parameter settings for the Q4ARCPU and QnPRHCPU, refer to the manuals of each CPU.

4 CONFIGURATION OF REDUNDANT SYSTEM

4.1 System Configuration

4.1.1 System configuration diagram

When replacing the Q4ARCPUs configuring redundant system with the QnPRHCPUs, employ the combination of main base unit and extension base unit or main base unit and MELSECNET/H (remote I/O).

(1) Configuration example with the Q4ARCPUs

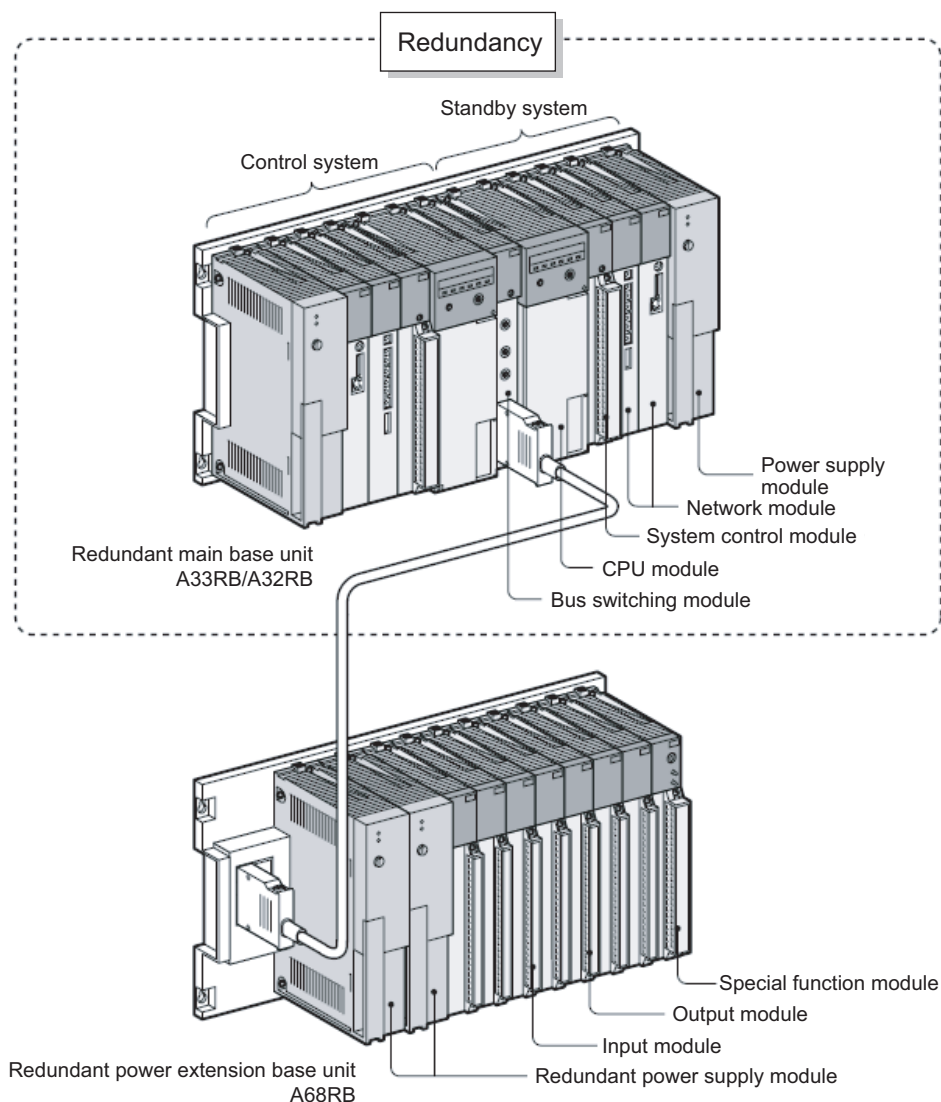

(2) Configuration example with the QnPRHCPUs

(a) Main base unit + Extension base unit

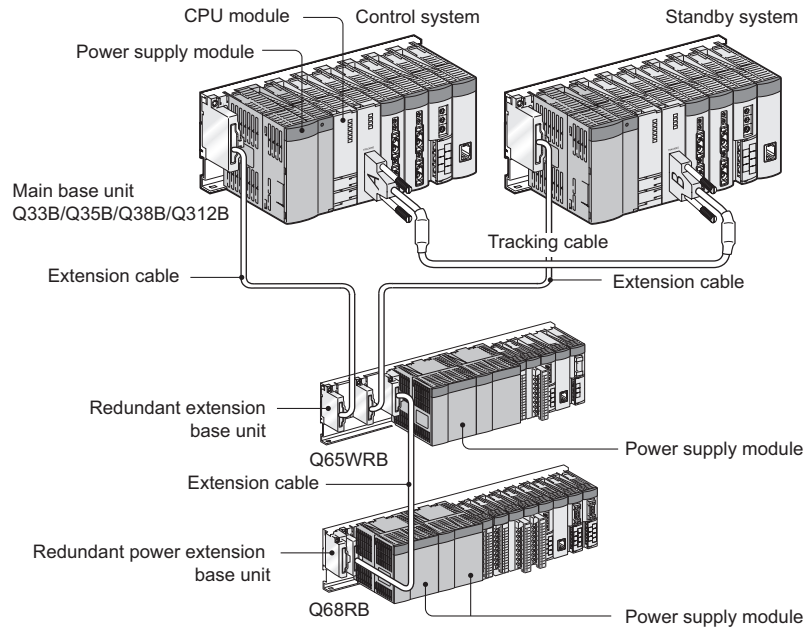

(b) Main base unit + MELSECNET/H (Remote I/O)

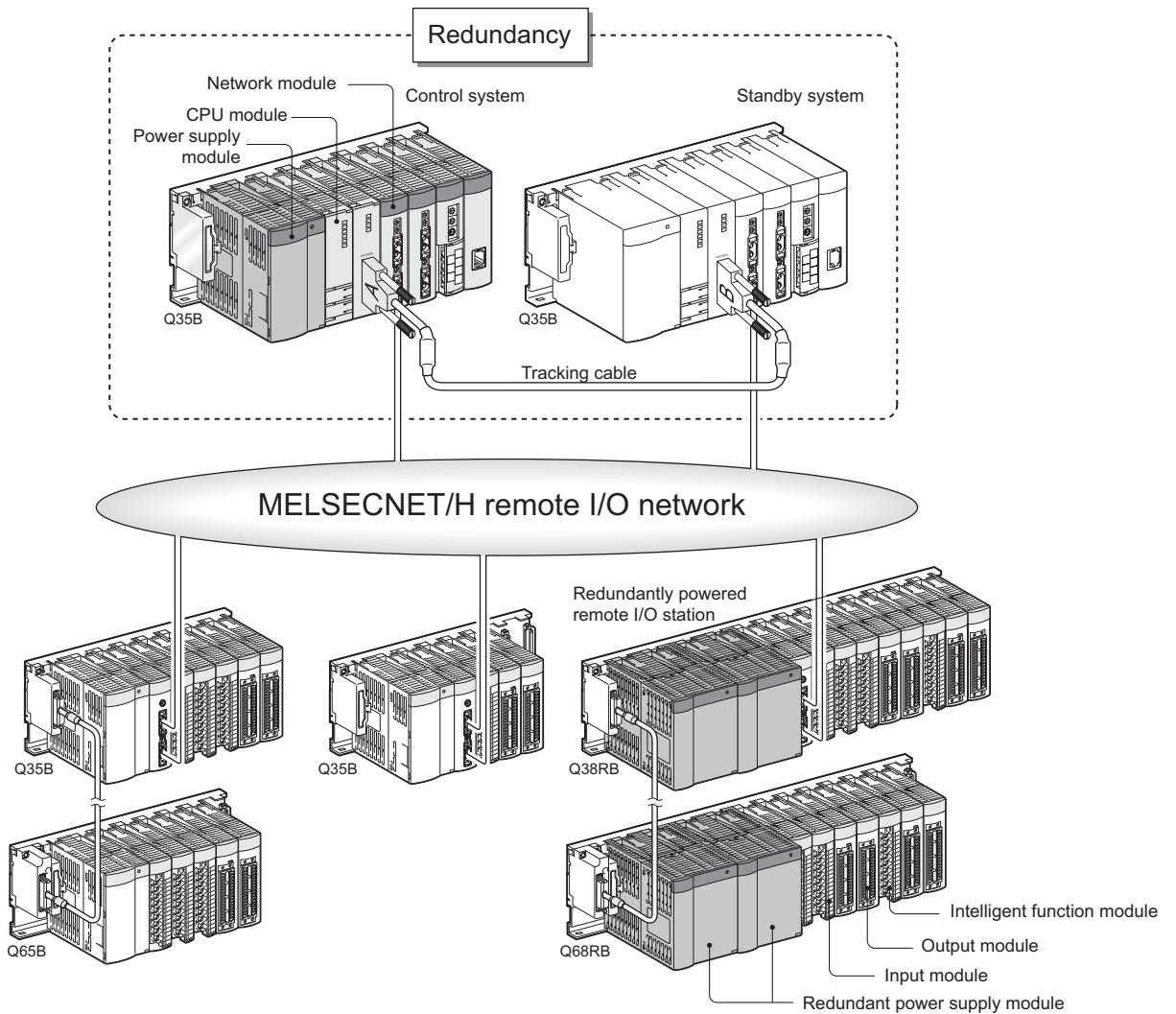

4.1.2 Precautions for replacement of redundant system

(1) System configuration precautions

(a) System A/System B configuration

Set up system A and system B so that they will be configured the same.

(b) Modules that can be mounted on a main base unit

The I/O modules used independently by the network module and system A or system B CPU module can be mounted on the same main base unit as a redundant CPU is mounted.

I/O modules and intelligent function modules used to control a redundant system must be mounted on MELSECNET/H remote I/O station or extension base unit.

Remote I/O stations, remote device stations, and intelligent device stations can be used by mounting CC-Link master modules on a main base unit or extension base unit.

(c) Modules that cannot be mounted to extension base unit

- CC-Link IE controller network module
- MELSECNET/H module
- Ethernet module (function version: B or earlier)
- Web server module (first five digits of serial number is 09011 or lower.)
- MES interface module (first five digits of serial number is 09011 or lower.)
- Interrupt module
- PROFIBUS-DP Slave Module
- PROFIBUS-DP Interface Module
- PROFIBUS-DP Master Module

(d) Modules where the number of mountable modules is restricted

The following table shows the modules that are restricted on the number of mountable modules.

Applicable Module	Type	Limitation on the number of mountable modules per system ^{*1}
MELSECNET/H module ^{*2}	<ul style="list-style-type: none"> • QJ71LP21-25 • QJ71LP21S-25 • QJ71LP21G • QJ71LP21GE • QJ71BR11 	Up to 4 in total of PLC to PLC network and remote I/O network modules
Ethernet module	<ul style="list-style-type: none"> • QJ71E71-B2 • QJ71E71-B5 • QJ71E71-100 	Up to 4
CC-Link master module	<ul style="list-style-type: none"> • QJ61BT11N 	Up to 8 ^{*3}

*1: The number of mountable modules per system indicates the number of modules that can be mounted on main base unit or extension base unit. Or, it indicates the number of modules that can be mounted on either one of the systems when they are mounted on main base unit.

*2: MELSECNET/H module cannot be mounted to the extension base unit.

*3: Possible only when the first five digits of serial number for the Redundant CPUs in both systems are "09102" or higher and GX Developer version is 8.58L or later.
In other combinations, the number of mountable modules per system is 4.

(e) Connecting extension base unit

- Use the Redundant CPUs whose first five digits of serial numbers are "09012" or higher for both systems.

The extension base unit cannot be connected to the main base unit where the Redundant CPU whose first five digits of serial number is "09011" or lower is mounted.

- The following extension base units cannot be connected to main base unit that mounts the Redundant CPUs.

Extension base unit : Q6□B, Q5□B

QA(1S) extension base unit : QA1S65B,QA1S68B,QA65B,QA68B

Extension base unit with QA conversion adapter: QA6ADP+A6□B,QA6ADP+A5□B

(f) Interrupt pointer to a module mounted on extension base unit

Any interrupt pointer caused by an interrupt from an intelligent function modules on extension base unit cannot be used.

(g) Accessing another station via extension base unit by MC protocol

Some commands cannot be used depending on the setting at Transfer setup.

The following table shows the availability of connection on each command of MC protocol.

Target	Function Command name	Transfer setup				
		Control system	Standby system	Not specified	System A	System B
Device memory	Batch read	○	○	○	○	○
	Batch write	○	○	○	○	○
	Random read	○	○	○	○	○
	Test (random write)	○	○	○	○	○
	Monitor data registration	×	×	×	○	○
	Monitor	×	×	×	○	○
	Multiple blocks batch read	○	○	○	○	○
	Multiple blocks batch write	○	○	○	○	○
Intelligent function module	Batch read	○	○	○	○	○
	Batch write	○	○	○	○	○
Programmable controller CPU	Remote RUN	○	○	○	○	○
	Remote STOP	○	○	○	○	○
	Remote PAUSE	○	○	○	○	○
	Remote latch clear	○	○	○	○	○
	Remote RESET	○	○	○	○	○
	CPU model read	○	○	○	○	○
File	Directory/file information read	×	×	×	○	○
	Directory/file information search	×	×	×	○	○
	New file creation	×	×	×	○	○
	File deletion	×	×	×	○	○
	File copy	×	×	×	○	○
	File attribute change	×	×	×	○	○
	File creation date change	×	×	×	○	○
	File open	×	×	×	○	○
	File read	×	×	×	○	○
	File write	×	×	×	○	○
	File close	×	×	×	○	○

○ : Transfer setup is possible. × : Transfer setup is impossible.

* Selection items on Transfer setup and their correspondence to communication system

Control system : Communications with a system that performs control and network communication in redundant system

Standby system : Communications with a system for backup in redundant system

Not specified : Communications with the following systems

- When CPU is directly connected:
Programmable controller CPU directly connected to the personal computer
- Via a module mounted on main base unit:
Programmable controller CPU at the station where the network module of the specified station number is installed in the network communication path
- Via a module mounted on extension base unit:
Programmable controller CPU operating as control system

System A : Communications with a system where system A connector for tracking cable is connected

System B : Communications with a system where system B connector for tracking cable is connected

Remarks

For details of each command, refer to the following manual.

Corresponding MELSEC Communication Protocol Reference Manual

(h) Compatibility with MELSOFT products

MELSOFT products connectable to a module mounted on the extension base unit are GX Developer and PX Developer. However, there are restrictions on applicable functions. For details, refer to the following manuals.

 GX Developer Version 8 Operating Manual

 PX Developer Version 1 Operating Manual (Programming Tool)

POINT

This handbook does not cover all precautions.

For details of precautions, refer to the following manual.

 QnPRHCPU User's Manual (Redundant System)

(2) Precautions for programming

In the programming of redundant system, there are various precautions (instructions with restrictions/ fixed scan clock/program).

The main items of precautions are as follows.

(a) Instructions restricted in use for redundant system

- Instructions requiring a certain number of scans
- Rise instruction
- Fall instruction
- SCJ instruction
- Instructions that change CPU status
- Restrictions when using special relay (SM1518) "Standby system to control system switching status flag"
- Restrictions on use of COM and ZCOM instructions
- Dedicated instructions for intelligent function module mounted to extension base unit

Remarks

The dedicated instructions for the intelligent function module mounted to the extension base unit cannot be used.

If used, a stop error "OPERATION ERROR" (error code: 4122) occurs.

For the dedicated instructions for the intelligent function module, refer to the manual for the intelligent function module to be used.

(b) Precautions on fixed scan clock and fixed scan execution type programs

- Fixed scan clock (SM409 to SM415, SM420 to SM424)
- Fixed scan execution type program
- Interrupt by the internal timer (I28 to I31)
- Interrupt from network module
- Interrupt during tracking transfer processing

(c) Precautions for using annunciator (F) in redundant system

(d) Precautions at system switching occurrence

- Precautions regarding access to intelligent function module and external device
- Precautions regarding timer
- Precautions regarding writing data from the GOT and external device etc.

(e) Precautions of programming when connecting extension base unit

- Precautions for using PX Developer
- Functions applicable in GX Developer and PX Developer
- Tracking device setting
- Availability of interrupt pointer

POINT

This handbook does not cover all precautions.

For details of precautions, refer to the following manual.

 QnPRHCPU User's Manual (Redundant System)

4.1.3 Restrictions on remote I/O station

This section explains restrictions on the MELSECNET/H remote I/O station on redundant system.

(1) Support for intelligent function module

(a) Buffer memory access

Use the REMFR/REMTO instruction for buffer memory access of intelligent function module (The FROM/TO instruction and intelligent function module device (U□\G□) cannot be used.) or specify auto refresh of intelligent function module (remote I/O station) with GX Configurator.

(b) Dedicated instruction and interrupt pointer

The dedicated instruction and interrupt pointer cannot be used for intelligent function module.

(c) Ethernet module

The e-mail function, communications by fixed buffer, FTP server function, and Web server function cannot be used for Ethernet module.

(2) Modules that cannot be mounted on the remote I/O station

The following modules cannot be mounted on the remote I/O station.

(a) MELSECNET/H module

(b) Interrupt module

(c) Web server module

4.1.4 I/O refresh delay time

The following table shows the I/O refresh delay time.

Device	Q4ARCPU	QnPRHCPU
X	2 sequence scans	3 sequence scans
Y	1 sequence scan	1 sequence scan + 9ms ^{*1}

*1: The time with the following conditions

- (1) The number of remote I/O stations in QnPRHCPU redundant system is 1.
- (2) 4096 points are assigned to LX and LY for each.

4.1.5 Comparison between the FROM/TO instruction and REMFR/REMTO instruction

The following table shows comparison between the FROM/TO instruction and REMFR/REMTO instruction.

	Q4ARCPU	QnPRHCPU □ ^{*2}	
	FROM/TO instruction	REMFR/REMTO instruction	Cyclic communication + Intelligent function module parameter
Condition (number of points)	1000 words	960 words	544 words
Writing to buffer memory	4.19ms	3 sequence scans	1 sequence scan + 20ms
Reading from buffer memory	4.15ms	3 sequence scans	2 sequence scans + 20ms

*2: The following conditions are assumed.

- (1) The number of remote I/O stations in QnPRHCPU redundant system is 1.
- (2) 4096 points are assigned to LX and LY for each.
- (3) 544 words are assigned to LW (M → R) and LW (M ← R) for each.

4.2 GOT Connection

The following table shows the connection type and availability of connection when GOT is used in redundant system.

Connection type	Availability of connection		Remarks	
	Q4ARCPU	QnPRHCPU		
Main base unit where Redundant CPU is mounted	Bus connection	○	×	-
	CPU direct connection	○	○	Communication is possible only with the CPU module to which GOT is connected.
	Computer link connection	○	×	The QnPRHCPU cannot be connected since the serial communication module cannot be mounted on the main base unit that mounts the Redundant CPU.
	Ethernet connection	○	○	The QnPRHCPU requires script setting on GOT side.
	MELSECNET/H PLC to PLC network	×	○	-
	MELSECNET/10 PLC to PLC network	○	○	-
	CC-Link connection	×	○	-
Extension base unit	Bus connection	○	×	No error occurs in the QnPRHCPU.
	Computer link connection	○	○	-
	Ethernet connection	○	○	-
	MELSECNET/H PLC to PLC network	×	×	The QnPRHCPU cannot be connected since the MELSECNET/H module cannot be mounted on the extension base unit.
	MELSECNET/10 PLC to PLC network	×	×	The QnPRHCPU cannot be connected since the MELSECNET/H module cannot be mounted on the extension base unit.
	CC-Link connection	○	○	-
MELSECNET/H remote I/O station	Bus connection	○	×	-
	CPU direct Connection	×	○	-
	Computer link connection	○	○	-
	Ethernet connection	×	○	-
MELSECNET/10 remote I/O station	Bus connection	×	×	The MELSECNET/10 cannot be connected since it is not compatible with the Redundant CPU.
	CPU direct connection	×	×	
	Computer link connection	×	×	
	Ethernet connection	×	×	-

○ : Connectable × : Not connectable

Remarks

Some GOT models cannot be connected.
 For the restrictions when the GOT is used in the redundant system, refer to the following manual.
 GT Designer2 Version2 Screen Design Manual

4.3 External Output

The following table shows the external output of QnPRHCPU redundant system.

Redundant CPU status		Description on external output
Normal operation		Output according to the operation result of a program.
At online program change	SM1710* ¹ is OFF. (default)	If a system switching occurs during online program change, the CPU module on new control system may output old data.
	SM1710* ² is ON.	The latest operation result is output since tracking transfer is performed during online program change. If a system switching occurs during online program change, old data are not output.
At power ON from OFF the control system/ standby system or resetting the CPU module on control system/standby system and then releasing the reset status	Backup mode	<ul style="list-style-type: none"> At power ON from OFF the control system or resetting the CPU module on control system and then releasing the reset status Turning ON/OFF the external output continues according to the forced ON/OFF information of the CPU module on new control system. At power ON from OFF the standby system or resetting the CPU module on standby system and then releasing the reset status Turning ON/OFF the external output continues according to the forced ON/OFF information of the CPU module on control system.
	Separate mode	<ul style="list-style-type: none"> At power ON from OFF the control system or resetting the CPU module on control system and then releasing the reset status (Modules on the main base unit) The external output changes according to device Y. (Modules on the remote I/O station) At power-OFF/reset The output status when the control system is powered OFF or the CPU module on control system is reset is held. At power-ON/releasing the reset status The external output changes according to device Y. At power ON from OFF the standby system or resetting the CPU module on standby system and then releasing the reset status Turning ON/OFF the external output continues according to the forced ON/OFF information of the CPU module on control system.
External output at CPU module failure		Output from the ERR terminal of the power supply module.

*1: SM1710 (Whether device memory tracking transfer is performed or not during online program change for redundancy)
 ON: Device memory tracking transfer is not performed.
 OFF: Device memory tracking transfer is performed.

4.4 Redundant System Operation Mode

4.4.1 Redundant system operation mode

The Q4ARCPU uses the backup mode and separate mode as operation mode, meanwhile the QnPRHCPU can use the debug mode in addition to these modes.

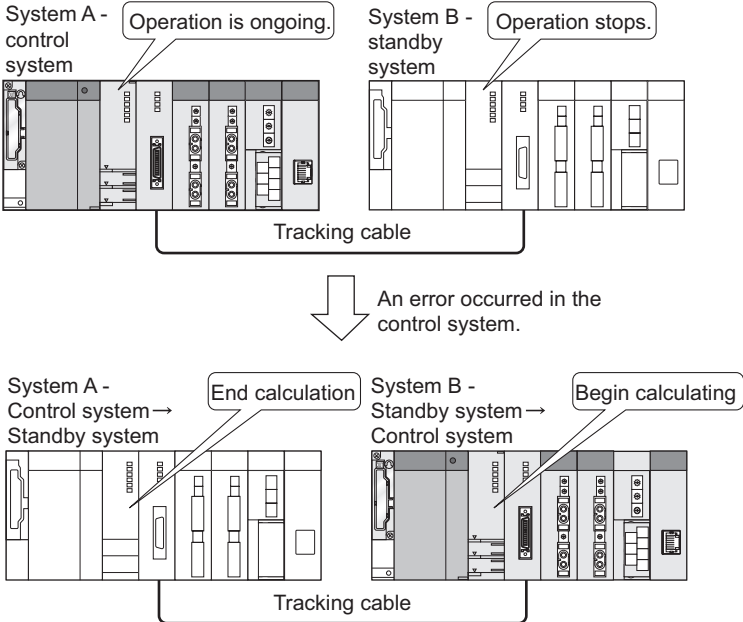
Operation mode for the QnPRHCPUs	Overview
Backup mode	<p>The backup mode is for normal operation of redundant system. If a fault or failure occurs in the control system, the standby system takes over the control and continues the system operation. To enable the standby system to continue the system operation when the control system goes down, the data of the control system must be continuously transferred to the standby system through the tracking cable.</p> 
Separate mode	<p>The separate mode is for maintenance (program modification, replacing the module mounted on the main base unit, etc.) without stopping control. In the separate mode, different programs can be run in the control system and standby system CPU modules.</p>
Debug mode	<p>The debug mode is for performing a debug using a single system prior to redundant system operation. No need to connect the tracking cable to perform the operation. (An error will not occur if the tracking cable is not connected.)</p>

4.4.2 Changing redundant system operation mode

2 types of redundant system operation mode change are available.

- Change from backup mode to separate mode
- Change from separate mode to backup mode

The Q4ARCPU changes the operation mode with "separate mode switch" of bus switching module, meanwhile the QnPRHCPU sets it with GX Developer.

The following shows the setting method for the QnPRHCPU.

(1) Changing the operation mode (GX Developer Version8)

The operation mode change is performed in the control system CPU module by the redundant operation.

(a) Change from backup mode to separate mode

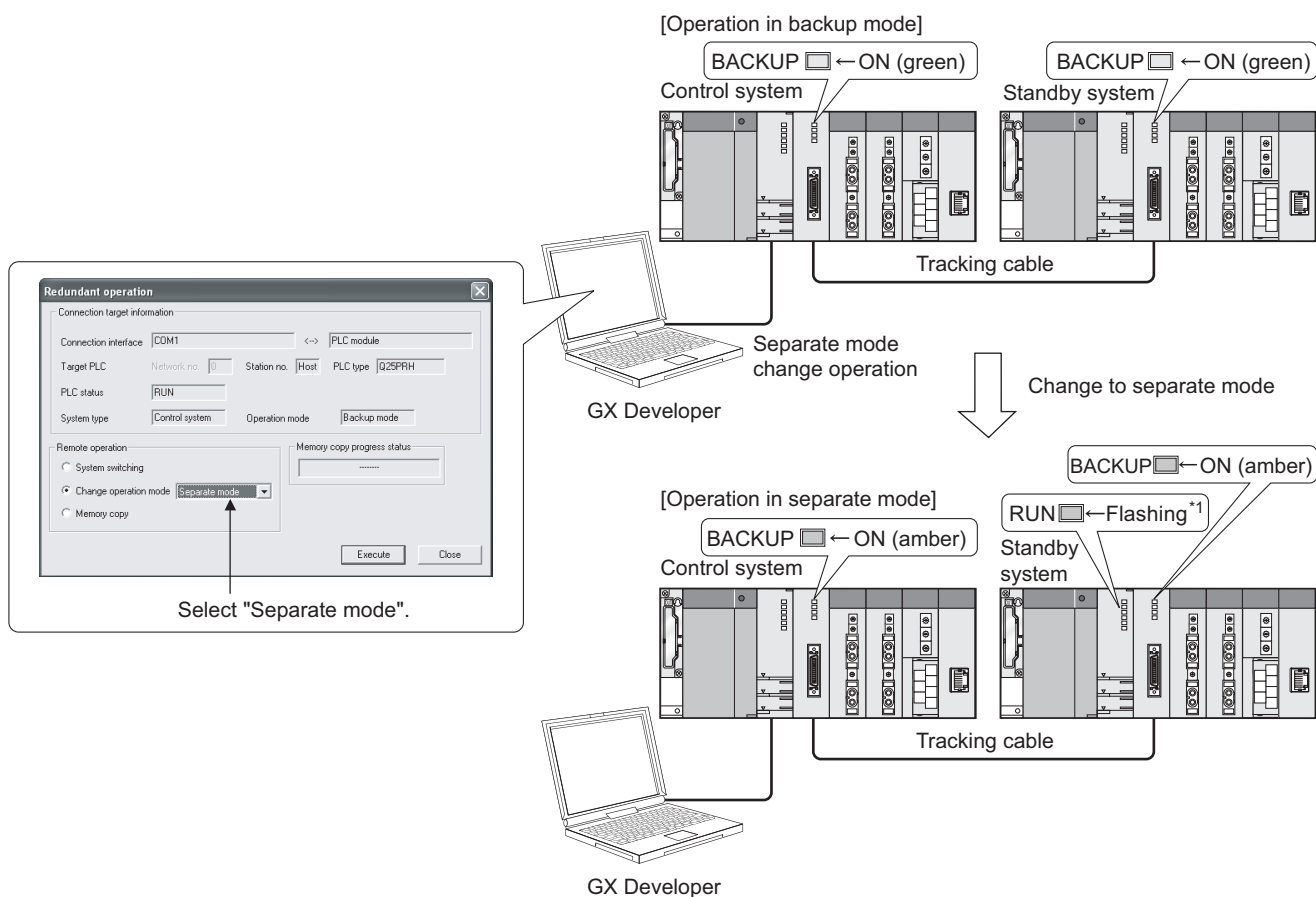

*1: When changing from the backup mode to the separate mode, the RUN LED of the standby system CPU module will flash and the control will be in a stop status.

(b) Change from separate mode to backup mode

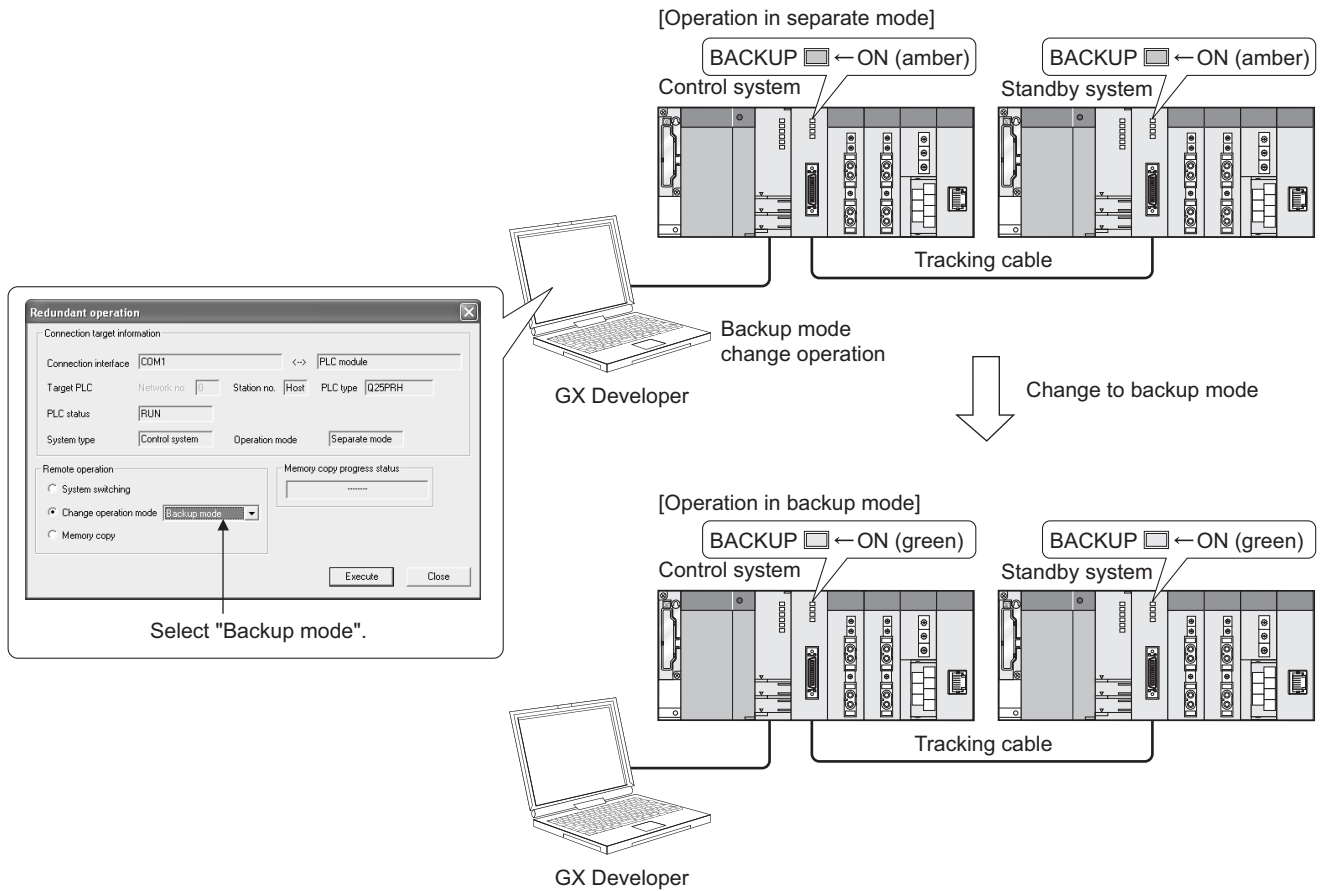

Remarks

The operation mode can be changed from the separate mode to backup mode by either of the following methods:

- Simultaneously power ON system A and system B.
- Simultaneously switch the CPU modules in system A and system B to RESET.

(c) Precautions

For details of precautions, refer to the following manual.

☞ QnPRHCPU User's Manual (Redundant System)

4.5 Deciding Control System/Standby System at Simultaneous Power-ON

The Q4ARCPU decides the control system with "simultaneous power-ON start mode setting switch" of bus switching module, meanwhile the QnPRHCPU always fixes it to system A.

For the QnPRHCPU, even when the both systems temporarily power OFF due to a power failure while system B is operating as the control system, system A starts as the control system after the both systems are powered ON again.

To start with system B, which is previous control system, as the control system, create a program using special relay "Previous control system identify flag (SM1519)".

However, when mounting a network module on the main base unit or extension base unit, create an interlock circuit as shown on the following program before executing the SP.CONTSW instruction.

If battery error occurs in either system and device data cannot be held, the operation cannot be guaranteed.

The following shows a program example.

Check that the network module has started, and create a program that executes the SP.CONTSW instruction as shown below.

[System configuration when MELSECNET/H module or Ethernet module is mounted on the main base unit]

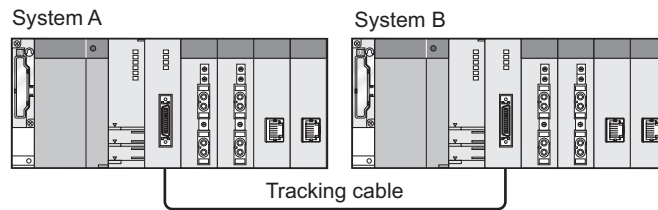

[Program example]*1

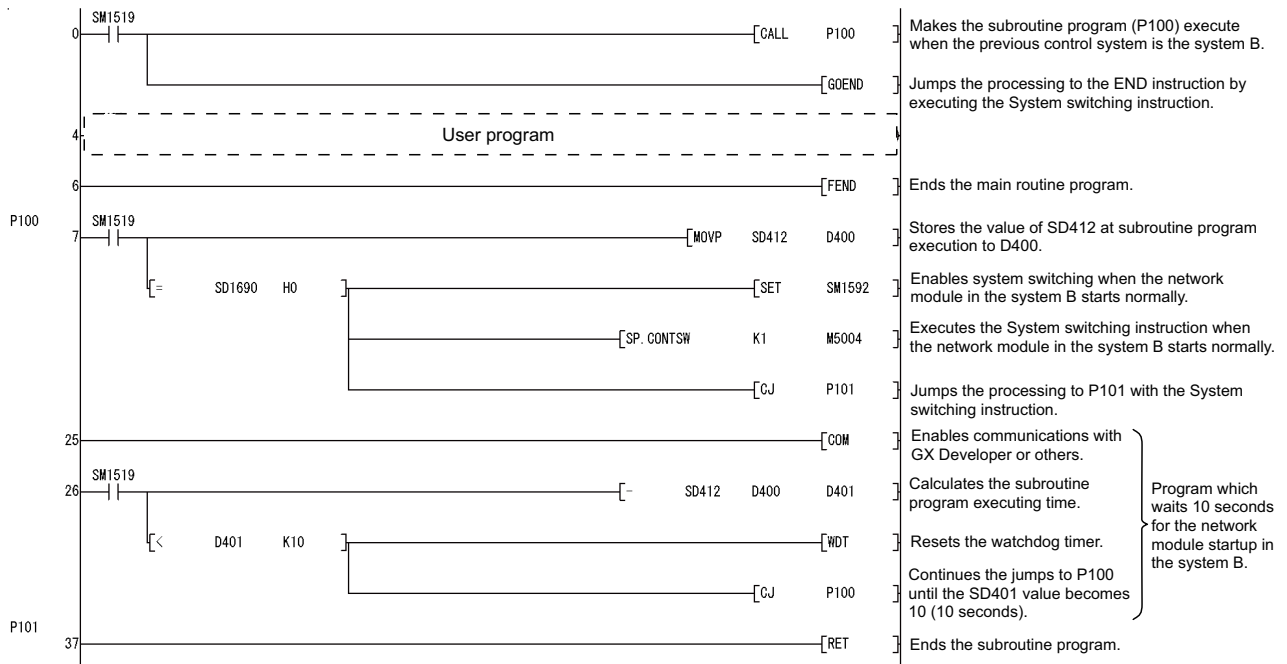

*1: Special relays and special registers used in the program example

Number	Name	Description
SM1519	Previous control system identify flag	When the previous control system was system B, it turns on for one scan at simultaneously powering on system A/system B or canceling the reset, after operating in RUN in system A.
SM1592	Manual switching enable flag	This flag enables system switching by the user from GX Developer or by System switching instruction. (SP.CONTSW).
SD412	1 second counter	The number of counts in units of 1 second • After the CPU module is in RUN status, 1 is added to each second.
SD1690	System switching request issue module number	Displays network module on another system where system switching request has been issued.

4.6 Operation Mode Setting at CPU Start-up

The Q4ARCPU sets the operation mode*1 with the S.STMODE instruction, meanwhile the QnPRHCPU sets it with parameters.

*1: When the Q4ARCPU is powered ON and started up, it can be specified whether the CPU devices are cleared at start-up or not cleared at start-up.

4.6.1 Operation mode for the QnPRHCPU

This section explains operation mode for the QnPRHCPU.

(1) Initial start mode for the QnPRHCPU (default)

This mode is for clearing all devices except the file register and the latch range settings device (word device: 0; bit device: OFF) before performing the operation.

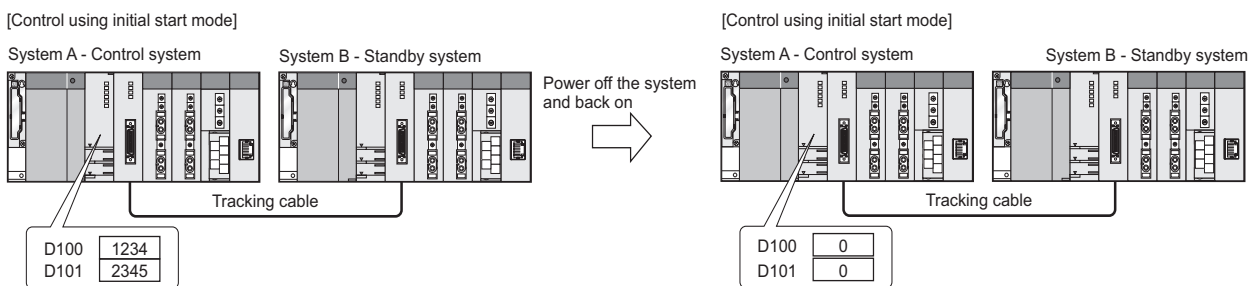

(2) Hot start mode for the QnPRHCPU

This mode is for performing the operation from when holding the device.

(Some devices such as the step relay and the index register will be cleared.)

As holding the devices even when the redundant system goes down due to power-OFF or CPU module reset, the system can continue the operation when it is powered on or the CPU modules are unreset (RESET/L.CLR switch is set to the neutral position)

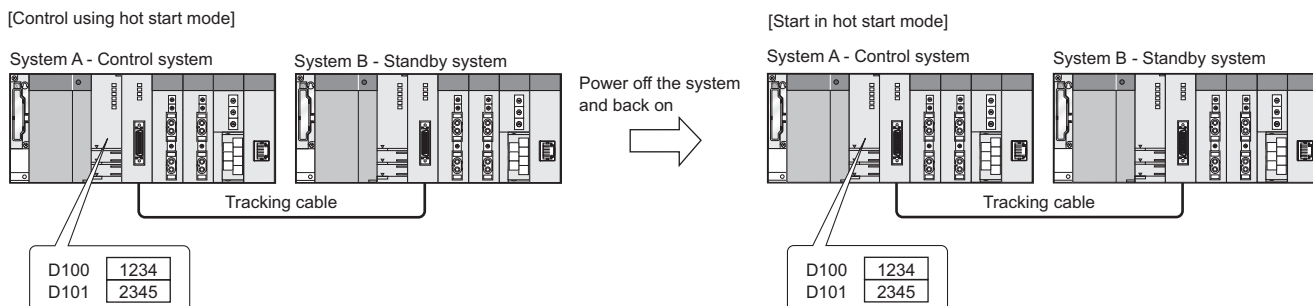

4.6.2 Operation settings screen for the QnPRHCPU

This section shows the "Operation settings" screen for the QnPRHCPU on GX Developer Version 8.

("Operation settings" screen)

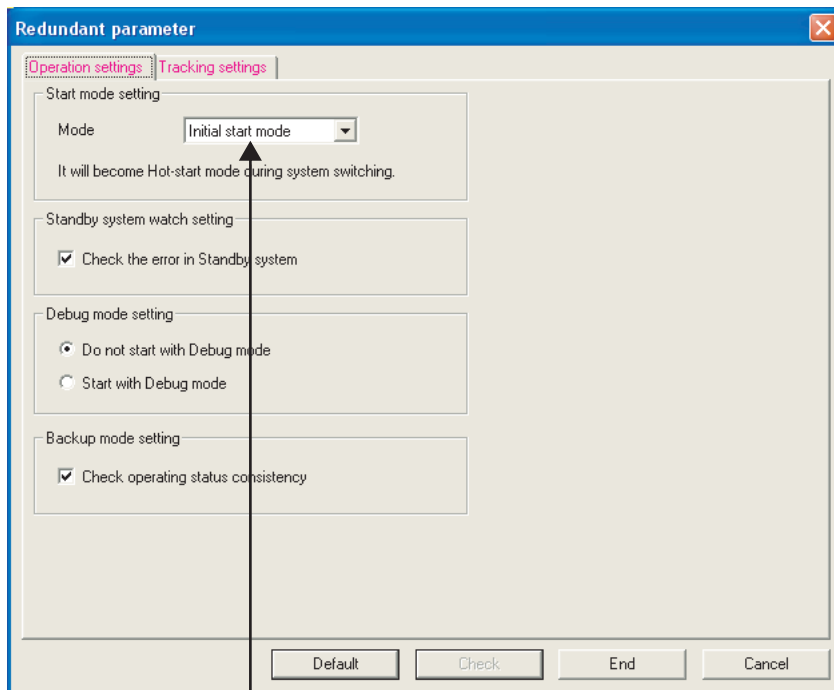

Select Initial start mode or Hot-start mode.

4.7 System Switching Method between Control System and Standby System

The Q4ARCPU sets the system switching with "bus switching switch" of bus switching module, meanwhile the QnPRHCPU sets it with GX Developer or the SP.CONTSW instruction.

4.7.1 Comparison of system switching causes

The following table shows comparison between Q4ARCPU and QnPRHCPU on system switching cause.

○ : Available × : Not available

System switching type	Cause	Q4ARCPU	QnPRHCPU	Remarks
User switching	Bus switching switch setting of bus switching module (A6RAF)	○	×	The QnPRHCPU does not have bus switching module.
	System switching with GX Developer	×	○	-
	Execution of the System switching instruction (SP.CONTSW)	×	○	-
System switching	Power-OFF of control system	○	○	-
	Reset of control system	○	○	-
	Hardware failure in control system	○	○	-
	Stop error in control system	○	○	-
	System switching request from the MELSECNET/H module on control system	○	○	-
	System switching request from the Ethernet module on control system	×	○	-

4.7.2 Operation mode setting at CPU switching

The Q4ARCPU sets the operation mode at CPU switching (system switching)^{*1} to either initial start or hot start with the S.CGMODE instruction, meanwhile the QnPRHCPU does not require setting since the operation mode is fixed to hot start.

*1: Set whether to clear CPU module devices when switching from control system to standby system.

4.7.3 User switching

The user switching switches a system manually during system operation.

Two types of the user switching are available: "system switching with GX Developer" and "system switching with the System switching instruction (SP.CONTSW instruction)". (The user switching is performed for the CPU module on control system.)

(1) System switching with GX Developer

When switching a system with GX Developer, the system switching is performed at END processing.

Perform system switching with GX Developer by the following procedure:

- 1) Turn ON (enable) the "Manual switching enable flag (SM1592)".
- 2) Perform system switching with the online redundant operation.

(System switching operation by GX Developer)

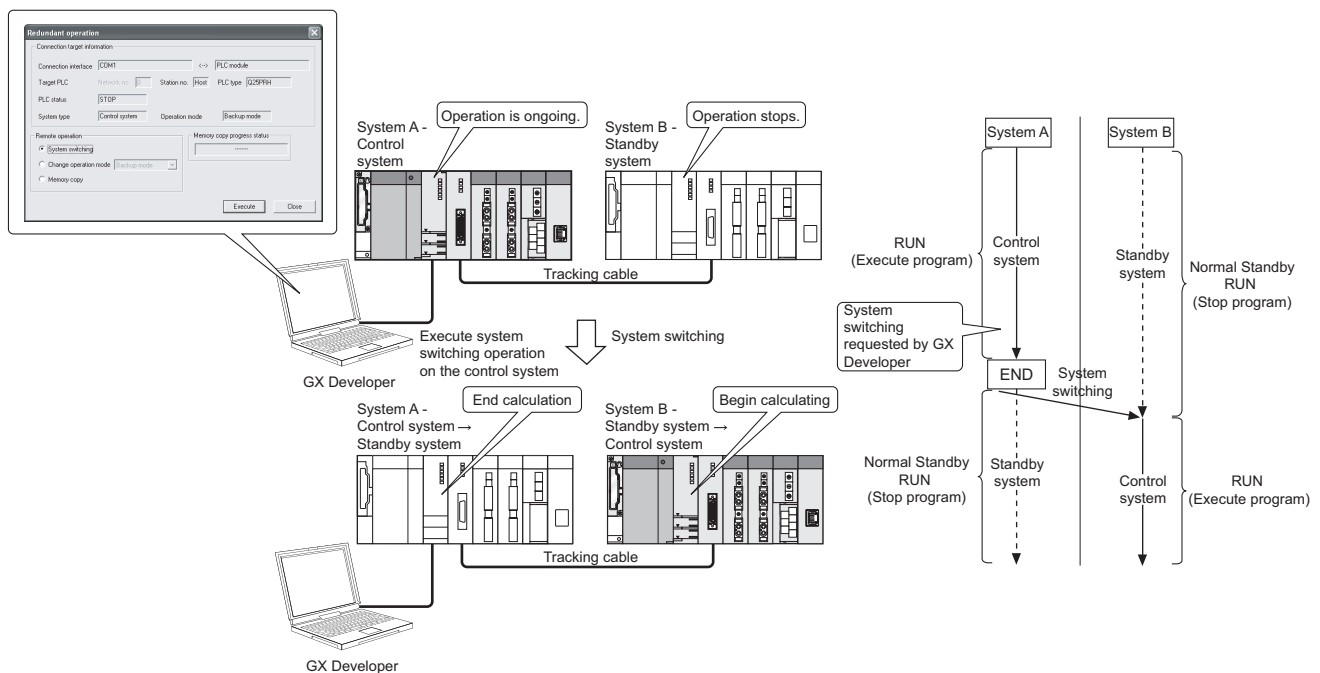

(2) System switching with the System switching instruction (SP. CONTSW instruction)

When executing the System switching instruction in the CPU module on control system, the system switching is performed at END processing after execution of the instruction.

Perform system switching with the System switching instruction by the following procedure:

- 1) Turn ON (enable) the "Manual switching enable flag (SM1592)".
- 2) Turn ON the executing condition for the System switching instruction and execute the System switching instruction.

(System switching operation by the System switching instruction)

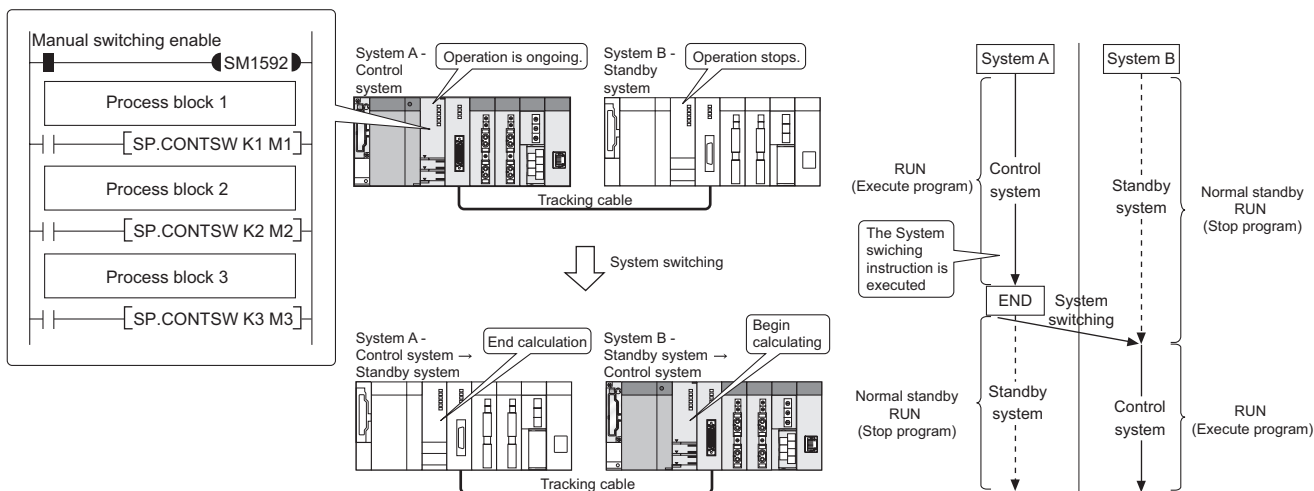

4.7.4 System switching time

The Q4ARCPU and QnPRHCPU differ in system switching time and output hold time at system switching.

Fully check the operations.

The following table shows comparison on switching time.

Item	Q4ARCPU	QnPRHCPU		
		Redundant extension base system	Remote I/O network system	
System switching time	300ms (maximum)	43ms ^{*1}		
Output hold time	Power-OFF Control system reset Control system hardware failure Control system stop error	300ms +1 sequence scan (maximum)	System switching time +1 sequence scan	630ms 1 sequence scan in control station (maximum) ^{*2}
	Switching switch	300 ms +2 sequence scans	-	-
	Dedicated switching instruction	-	System switching time +2 sequence scans	170ms +2 sequence scans in control station ^{*2}

*1: The time with the following conditions

- 1) Perform refresh of X/Y 4096 points.
- 2) Signal flow does not transferred.
- 3) Perform tracking of 48k-word file register (SRAM memory card).

*2: Output hold time of remote I/O station

4.8 Output Hold Specification at Stop Error

The Q4ARCPU sets the output hold specification at stop error*¹ with "output hold/reset mode switch" of bus switching module, meanwhile the QnPRHCPU sets it with parameters (can be set per module).

*1: Set whether to clear or hold outputs when stop error occurs in CPU modules on both systems in redundant system.

4.8.1 Output mode at QnPRHCPU error

This section explains output mode when an error occurs in the QnPRHCPU.

(1) Setting "Error time output mode" to "Clear" (default)

All outputs of the module to which "Clear" is set are turned OFF.
(Output (Y) in the device memory is held.)

(2) Setting "Error time output mode" to "Hold"

Outputs of the module to which "Hold" is set are held.
(Output (Y) in the device memory is held.)

4.8.2 Output operation from remote I/O station during an error

This section explains output operation when an error occurs in the QnPRHCPU or remote I/O station.

(1) Operation when an error occurs in the Redundant CPU (remote master station)

Settings of operation mode for error occurrence		Redundant CPU control status	Data link operation of MELSECNET/H remote I/O network	Output operation from remote I/O station
Redundant CPU	Remote I/O station			
Stop	Stop	Stops control. (stop error)	All stations stop data link.	Depends on the output mode hold/clear settings for error occurrence.
	Continue			
Continue	Stop	Continues control. (continuation error)	All station continue data link.	All stations output normally.
	Continue			

(2) Operation when an error occurs in remote I/O station

Settings of operation mode for error occurrence		Redundant CPU control status	Data link operation of MELSECNET/H remote I/O network	Output operation from remote I/O station
Redundant CPU	Remote I/O station			
Stop	Stop	Stops control. (stop error)	All stations stop data link.	Depends on the output mode hold/clear settings for error occurrence.
	Continue			
Continue	Stop	Continues control. (continuation error)	The faulty station is disconnected from the system. The other stations continue normal data link.	The output of the faulty station follows the hold/clear setting in the error-time output mode. Stations other than faulty station output normally.
	Continue		All stations continue data link.	All stations output normally.

4.8.3 Output mode setting during QnPRHCPU error

This section shows the screens for setting "Error time output mode" for the QnPRHCPU on GX Developer Version 8.

("I/O assignment" screen)

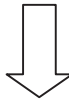
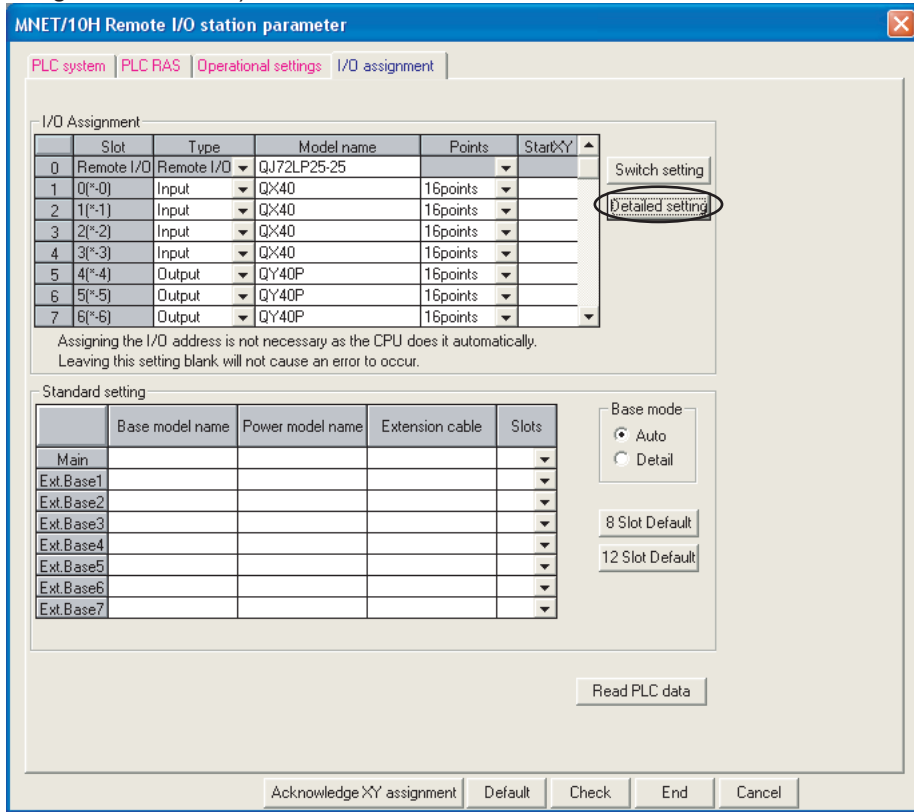

("Detailed setting" screen)

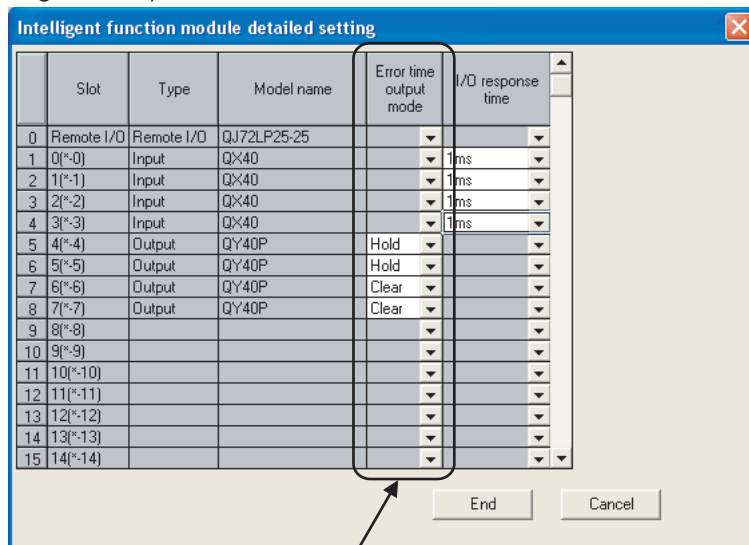

Set either "Hold" or "Clear" at "Error time output mode" to each module.

4.9 Tracking Redundant System

The Q4ARCPU makes the redundant system tracking setting*1 with the S.TRUCK instruction, meanwhile the QnPRHCPU makes it with parameters.

*1: Setting for keeping the data in control system and standby system same so that the standby system can continue the operation in case of system down of the control system

The QnPRHCPU can perform tracking transfer without setting since tracking transfer setting data are set at default.

Tracking transfer can be executed in either backup mode or separate mode.

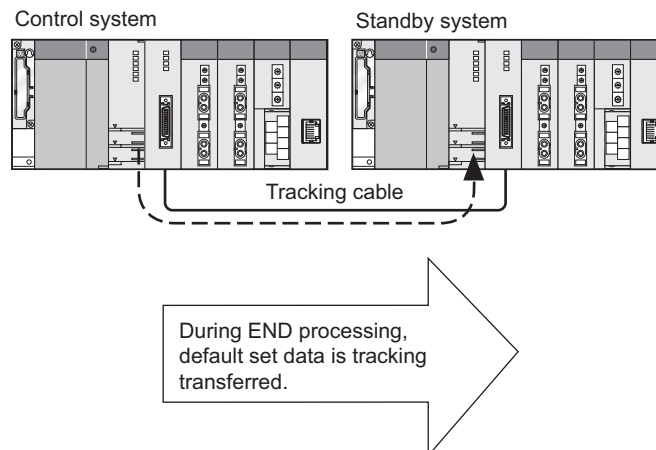

POINT

Tracking the QnPRHCPU

(1) Tracking transfer cannot be performed in the following situations.

(a) The tracking cable is disconnected or is a failure (TRK. DISCONNECT (error code: 6130)).

Make sure the tracking cable is connected or replace the cable.

(b) If the following malfunctions occur on the standby system:

- Standby system power supply is off.
- A stop error occurs on the standby system CPU module.
- The standby system CPU module is resetting.

(Tracking transfer can be performed if reset is canceled in standby system CPU module.)

(2) Set the following devices as tracking devices.

- Device that makes auto refresh setting to the intelligent function module on the extension base unit with GX Configurator

- Device that makes auto refresh setting to the CC-Link master module on the extension base unit

When tracking device setting is not made, the program is executed with the values before refresh at first scan after system switching.

4.9.1 Tracking transfer setting data of the QnPRHCPU

There are 2 types of tracking transfer setting data: tracking data based on the transfer range set by the user and tracking data automatically transferred.

(1) Transfer data range setting by user

The transfer data range and transfer timing can be set by the user.

This applies to the internal devices and signal flow memory. (Set whether the signal flow memory is tracking transferred or not.)

Up to 100k words of internal devices and signal flow memory can be transferred for each tracking transfer.

(2) Auto transfer data

Auto transfer data is the data that the redundant CPU tracks regardless of the redundant parameter tracking settings.

The data settings cannot be changed by changing the redundant parameter tracking settings.

This applies to the SFC information, PID control instruction information. some special relays and special registers.

Type		Description	Auto transfer *1	Setting change by user *2	Operation mode *3	
					Backup mode	Separate mode
Device data	Internal device	Data of input (X), output (Y), internal relay (M) and others used in programs	○ *4	○	○	○
	Special relay	Data turned ON or OFF by user or system	○	×	○	○
	Special register	Data stored by user or system	○	×	○	○
Signal flow memory		Data that determines whether the rise and fall instructions will be executed or not in sequence programs	×	○	○	×
SFC information		Data used to execute SFC	○	×	○	×
PID Control instruction information		PID control data specified by PIDINIT and S.PIDINIT instructions	○	×	○	×

*1: ○ : Auto transfer enabled, × : Auto transfer disabled

*2: ○ : Setting change enabled, × : Setting change disabled

*3: ○ : Tracking transfer enabled, × : Tracking transfer disabled

*4: The device range set by default will be transferred.

4.9.2 Setting tracking data of the QnPRHCPU

This section shows the "Tracking settings" screen for the QnPRHCPU on GX Developer Version 8.

("Tracking settings" screen)

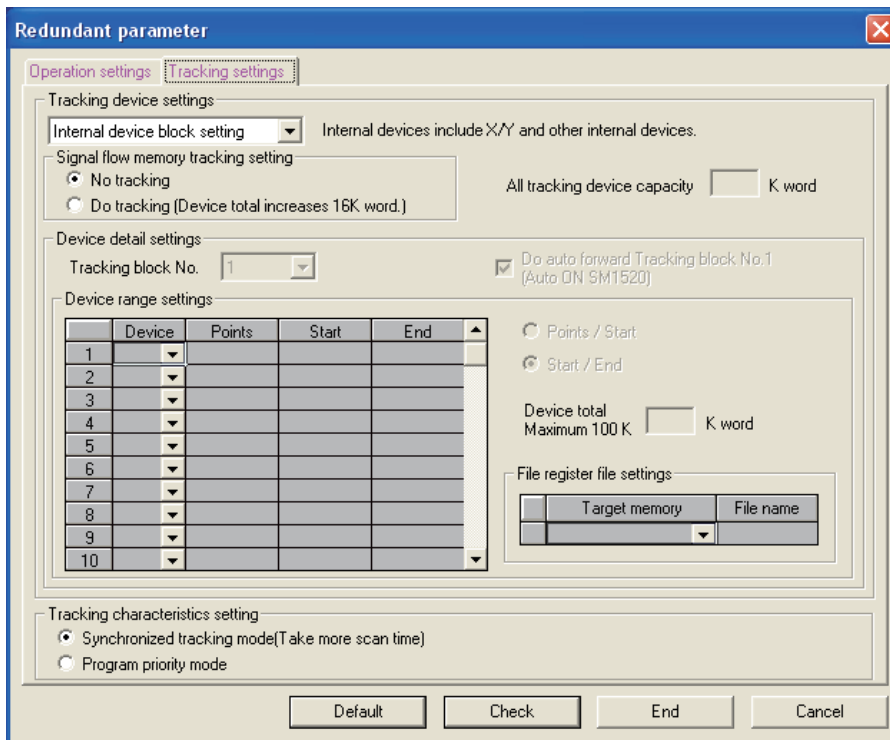

4.9.3 Tracking transfer time

Fully check operations as the QnPRHCPU and Q4ARCPU differ in tracking transfer time. The following table shows comparison on the tracking transfer time.

Item	QnPRHCPU redundant system		Q4ARCPU redundant system	
	Internal device	When 48k words is set	Internal device	When 48k words is set
Tracking transfer time		Synchronized tracking mode: 41 ms ^{*1}		-
		-		Batch transfer mode: 68.4 ms
		Program priority mode: 21 ms ^{*1}		Repeat mode: 34.2 ms ^{*1}

*1: Q4ARCPU repeat mode results in program priority mode on QnPRHCPU.

4.10 MELSECNET/10(H) Pairing Setting

The Q4ARCPU makes the MELSECNET/10(H) pairing setting*1 with the J.PAIRSET instruction, meanwhile the QnPRHCPU makes it with common parameters for control station.

*1: Setting for continuing data link by transferring the own station when a system is switched in redundant system

POINT

- (1) For precautions when configuring MELSECNET/H system in redundant system composed of the QnPRHCPUs, refer to the following manual.
☞ Q Corresponding MELSECNET/H Network System Reference Manual (PLC to PLC network)
- (2) For MELSECNET/H module used for redundant system composed of the QnPRHCPUs, use the module of function version D or later.

An example of pairing setting using system configuration example below is explained.

(1) System configuration example

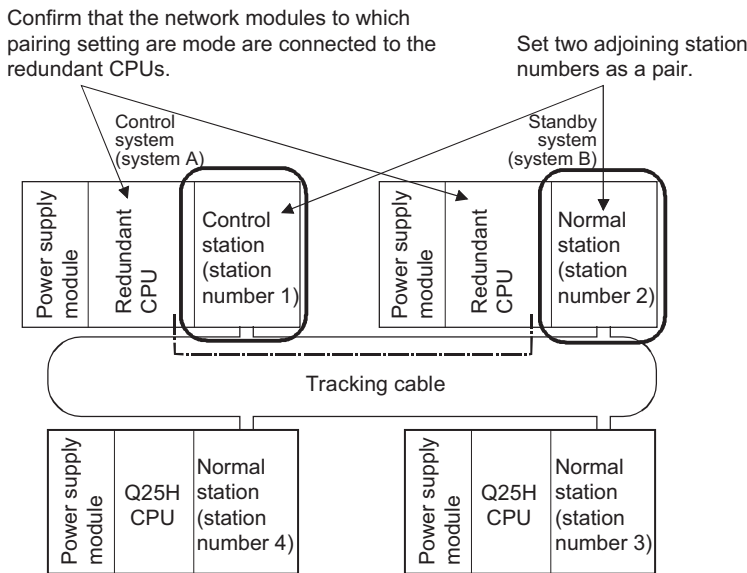

(2) Pairing setting example

This example shows the send range for each station (LB/LW setting) when 256 points are assigned to each of station Nos. 1 to 4.

Station No.	Send range for each station LB			Send range for each station LW			Send range for each station Low speed LB			Send range for each station Low speed LW			Pairing
	Points	Start	End	Points	Start	End	Points	Start	End	Points	Start	End	
1	256	0000	00FF	256	0000	00FF							Enable
2	256	0000	00FF	256	0000	00FF							Enable
3	256	0100	01FF	256	0100	01FF							Disable
4	256	0200	02FF	256	0200	02FF							Disable

- 1) To pair station Nos. 1 and 2, set the smaller station number to "Enable" (station No. 1 in this case).
- 2) By setting station No. 1 to "Enable", the send range for station No. 1 will be copied as that for station No. 2.

(3) Cyclic transmission processing when the redundant system communicates normally

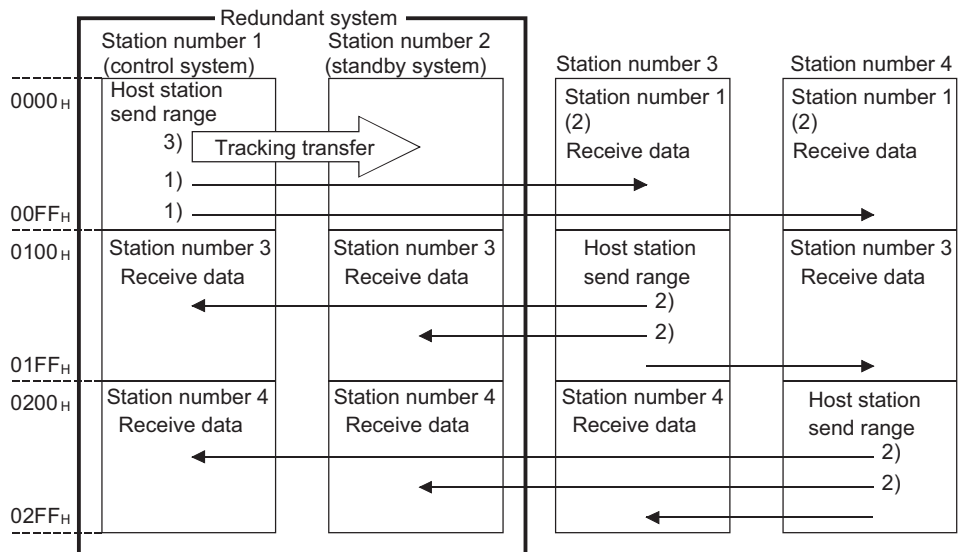

- 1) The send range for the redundant system is sent from the control system CPU of station number 1 or 2.
- 2) Station numbers. 1 and 2 receive data from another station.
- 3) The data sent from station number 1 of the control system CPU to another station are tracking-transferred to the standby system CPU as tracking device data.

4.11 MELSECNET/H Redundant Settings

The Q4ARCPU makes the redundant settings with the rotary switch of data link module, meanwhile the QnPRHCPU makes it with parameters.*1

- *1: Setting for the operation mode of network module mounted on system B in redundant system
Set the operation mode of system B when using the redundant system as backup to the same mode as system A.

The following shows the "Redundant settings" screen when the QnPRHCPU is set on GX Developer Version 8.

(Network parameter setting screen)

Module 1	
Network type	MNET/H mode (Control station)
Starting I/O No.	0000
Network No.	1
Total stations	4
Group No.	0
Station No.	
Mode	On line
Network range assignment	
Refresh parameters	
Interrupt settings	
Return as control station	
Redundant settings	



("Redundant settings" screen)

Redundant settings [Close]

Network type: MNET/H mode (Control station)

Start I/O No.: 0000

Mode(System A): On line

Mode(System B): On line

Mode(System B) dropdown menu:

- On line
- Debug mode
- Off line
- Forward loop test
- Reverse loop test
- Test between master station
- Test between slave station

End Cancel

Click the "Redundant settings" button.

4.12 Buffer Memory Batch Refresh

The Q4ARCPU sets the buffer memory batch refresh with the S.SPREF instruction, meanwhile the QnPRHCPU sets it with GX Configurator*1.

*1: Setting for automatically reading/writing data from/to the buffer memory in special function module/intelligent function module
 Auto refresh setting data set with GX Configurator are stored into the intelligent function module parameter of CPU module.

The following shows the setting example for QnPRHCPU on GX Configurator when using GX Developer Version 8.

The initial setting and auto refresh setting can be made by adding GX Configurator compatible with intelligent function module into GX Developer.

If they are made on GX Configurator, data can be written/read without creating a program for communications with intelligent function module.

(GX Configurator "Auto refresh setting" screen)

The following explains with an example when the initial setting and auto refresh setting are made for the A/D converter module, Q64AD.

In auto refresh setting, set devices on CPU module side to store the following data.

- Digital output values for each channel
- Maximum/minimum values for each channel
- Error codes

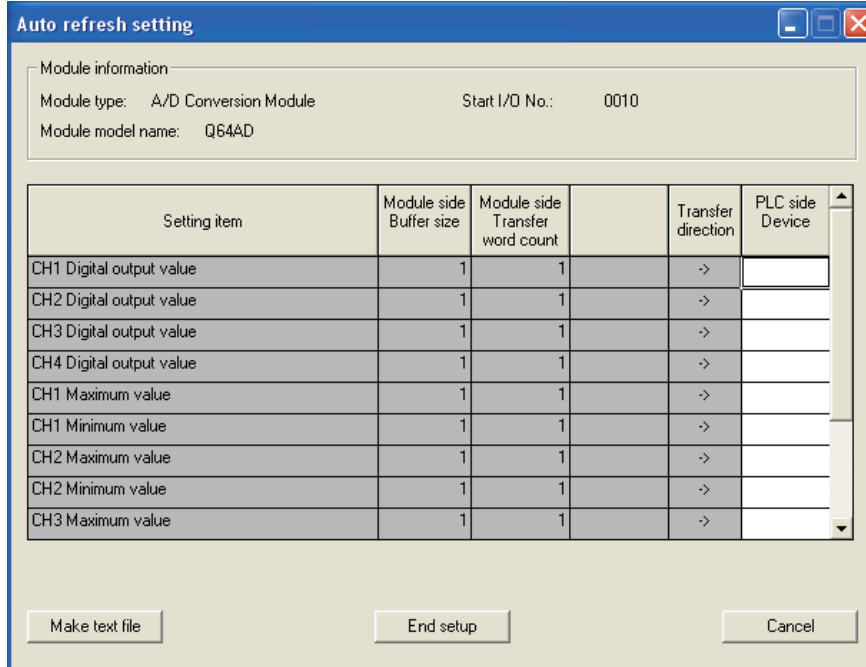

4.13 Programming Tool

The connection type for programming tool of the QnPRHCPU differs from that of the Q4ARCPU. The following table shows comparison on the programming tools and connection ports.

Item		Q4ARCPU	QnPRHCPU	Remarks
Programming tool	SW <input type="checkbox"/> /IVD-GPPQ-E	Available	Not available	Use GX Developer.
	SW <input type="checkbox"/> D5C-GPPW-E (GX Developer)	Available (SW2D5C-GPPW-E or later)	Available Supporting the MELSECNET/H remote I/O station: (SW8D5C-GPPW-E Version 8.17T or later) Supporting the extension base unit: (SW8D5C-GPPW-E Version 45X or later)	-
Connection port		RS422	RS-232	RS-232 cable (QC30R2) and USB cable are necessary.
			USB	RS-232 cable (QC30R2) and USB cable are necessary.

4.14 Restrictions on Instructions

The QnPRHCPU cannot use the following instructions.

Instruction symbol	Instruction Name	Instruction symbol	Instruction Name
LED	LED indication of ASCII code	PR	Print ASCII code
LEDC	LED display of comments	PRC	Print comments
SLT	Status latch set	KEY	Numerical key input
SLTR	Status latch reset	UDCNT1	Up/down counter
STRA	Sampling trace set	UDCNT2	Up/down counter
STRAR	Sampling trace reset	TTMR	Teaching timer
PTRAEXE(P)	Program trace execution	STMR	Special function timer
PTRA	Program trace set	ROTC	Shortest direction control instruction
PTRAR	Program trace reset	RAMP	Ramp signal instruction
MSG	Message displayed on peripherals	SPD	Pulse density measurement
PKEY	Key input from a peripheral	PLSY	Pulse output
RFRP	Read from remote I/O station special function module	PWM	Pulse width modulation
RTOP	Write to remote I/O station special function module	MTR	Matrix input

4.15 Compatibility of the Process (PID) Control Instructions

The Process (PID) control instructions of the Q4ARCPU are the same operation style and are compatible with those of the QnPRHCPU; therefore, they do not require modification.

The following table shows comparison on the Process (PID) control instructions.

○ : The instruction is available. × : The instruction is not available.

Item		Q4ARCPU	QnPRHCPU
PID control instruction	Complete differentiation	○	○ *1
	Incomplete differentiation	×	○ *1
Application PID instruction		○	○ *2
Process control instruction		○	

*1: Refer to QCPU (Q Mode)/QnACPU Programming Manual (PID Control Instructions).

*2: Refer to QnPHCPU/QnPRHCPU Programming Manual (Process Control Instructions).

5 SPECIAL RELAYS

When replacing the Q4ARCPUs with the QnPRHCPUs by "Change PLC type" on GX Developer, the special relays are converted into the same numbers. However, some special relays are not compatible with the Q4ARCPU or QnPRHCPU.

When using the incompatible special relay, review the program and correct it if necessarily.

(1) Process control instructions

○ : Compatible △ : Partial change required × : Not compatible

Number	Name	Description	Explanation	Corresponding CPU	Compatibility	Precautions for replacement
SM1500	Hold mode	OFF : No-hold ON : Hold	• Specifies whether or not to hold the output value when a range over occurs for the S.IN instruction range check.	Q4ARCPU QnPRHCPU	○	-
SM1501	Hold mode	OFF : No-hold ON : Hold	• Specifies whether or not the output value is held when a range over occurs for the S.OUT instruction range check.			

(2) For redundant systems (Host system CPU information *1)

SM1510 to SM1599 are only valid for redundant systems.

All off for standalone systems.

○ : Compatible △ : Partial change required × : Not compatible

Number	Name	Description	Explanation	Corresponding CPU	Compatibility	Precautions for replacement	
SM1510	Operation mode	OFF : Redundant system backup mode, stand-alone system ON : Redundant system separate mode	• Turns on when the operation mode is redundant system separate.	Q4ARCPU QnPRHCPU	○	-	
SM1511	Start mode at power-on	OFF : System A fixed mode ON : Previous control system latch mode	• Turns on when the start mode for a redundant system when the power supply is turned on is the previous control system latch mode.	Q4ARCPU	×	The QnPRHCPU does not have this function. Review the program.	
SM1512	Operation mode at CPU module start-up	OFF : Initial start ON : Hot start	• Turns on when the CPU module operation mode is hot start when the redundant system is started up.			The QnPRHCPU is not compatible with this relay since the operation mode is set with parameters. Review the program.	
SM1511	System A identify flag	<ul style="list-style-type: none"> Distinguishes between system A and system B. The flag status does not change even if the tracking cable is disconnected. 	When TRK. CABLE ERR. (error code: 6120) occurs (Unknown)	QnPRHCPU	New	-	
	System A	System B					
SM1512	System B identify flag						
		SM1511 : ON System A : OFF	OFF				
		SM1512 : OFF System B : ON	OFF				
SM1513	Operating status at CPU module start-up	OFF : Initial start ON : Hot start	• Turns on when the CPU module operating mode is hot start when the redundant system is actually start up.	Q4ARCPU	×	The QnPRHCPU always starts with hot start mode independent of power failure time. Review the program.	
	Debug mode status flag	OFF : Not in debug mode ON : Debug mode	• Turns on when the redundant system operating mode is set to debug mode.	QnPRHCPU	New	-	

*1: The information of the host CPU module is stored.

○ : Compatible △ : Partial change required × : Not compatible

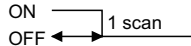
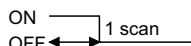
Number	Name	Description	Explanation	Corresponding CPU	Compatibility	Precautions for replacement		
SM1514	Operation mode at CPU module switching	OFF : Initial start ON : Hot start	• Turns on when the operation mode is hot start when the CPU module operation is switched for a redundant system.	Q4ARCPU	×	The QnPRHCPU does not have this function. Review the program.		
SM1515	Output hold mode	OFF : Output reset ON : Output hold	• Turns on when the output mode during a stop error is output hold.	Q4ARCPU	×	The QnPRHCPU is not compatible with this relay since the operation mode is set with parameters. Review the program.		
SM1516	Operation system status	OFF : Control system ON : Standby system	• Turns on when the CPU module operation system status is the standby system.		○	-		
SM1515	Control system identify flag	<ul style="list-style-type: none"> Indicates operation system status. The flag status does not change even if the tracking cable is disconnected. 		QnPRHCPU	New	-		
SM1516	Standby system identify flag		Control system				Standby system	When TRK. CABLE ERR. (error code: 6120) occurs (Unknown)
		SM1515	ON				OFF	OFF
SM1516		SM1516	OFF	ON	OFF			
SM1517	CPU module startup status	OFF : Power supply on start-up ON : Operation system switching start-up	<ul style="list-style-type: none"> Turns on when the CPU module is started up by the operation system switching. Reset using the user program. Turns on when the CPU module is started up by the system switching (switching from the standby system to the control system). Remains OFF when the standby system is switched to the control system by a power-ON startup. 	Q4ARCPU QnPRHCPU	○	-		
SM1518	Tracking execution mode	OFF : Batch transfer mode ON : Carryover mode	<ul style="list-style-type: none"> When this relay is turned OFF, the start of tracking is delayed until it is executable if the tracking memory is being used at END. When this relay is turned ON, the start of tracking is carried over to next END if the tracking memory is being used at END. 	Q4ARCPU	×	The QnPRHCPU is not compatible with this relay since the operation mode is set with parameters. Review the program.		
	Standby system to control system switching status flag	ON  OFF	<ul style="list-style-type: none"> Turns ON after standby system is switched to control system, (ON for 1 scan only) occurs. This contact can only be used for scan execution type programs. 	QnPRHCPU	New	-		
SM1519	Previous control system identify flag	ON  OFF	• When the previous control system was system B, it turns on for one scan at simultaneously powering on system A/system B or canceling the reset, after operating in RUN in system A.	QnPRHCPU	New	-		
SM1520	Data tracking transfer trigger specification	OFF : No trigger ON : Trigger	SM1520	Block 1	<ul style="list-style-type: none"> <In the case of Q4ARCPU> When data is transferred by the data tracking instruction S. TRUCK, the target block is specified as trigger. <In the case of QnPRHCPU> When data is transferred based on the tracking settings of the redundant parameter dialog box, the target block is specified as trigger. When "Do auto forward Tracking block No. 1" is enabled in the tracking settings, SM1520 is turned ON by the system at power-ON/STOP to RUN. In other cases, SM1520 to SM1583 are turned ON by the user. 	Q4ARCPU QnPRHCPU	○	-
SM1521			Block 2					
SM1522			Block 3					
SM1523			Block 4					
SM1524			Block 5					
SM1525			Block 6					
SM1526			Block 7					
SM1527			Block 8					
SM1528			Block 9					
SM1529			Block 10					
SM1530			Block 11					
SM1531			Block 12					
SM1532			Block 13					
SM1533			Block 14					
SM1534			Block 15					
SM1535			Block 16					
SM1536			Block 17					
SM1537			Block 18					
SM1538			Block 19					
SM1539			Block 20					
SM1540			Block 21					
SM1541			Block 22					
SM1542			Block 23					
SM1543			Block 24					
SM1544			Block 25					
SM1545			Block 26					
SM1546			Block 27					
SM1547			Block 28					

○ : Compatible △ : Partial change required × : Not compatible

Number	Name	Description	Explanation	Corresponding CPU	Compatibility	Precautions for replacement	
SM1548	Data tracking transfer trigger specification	OFF : No trigger ON : Trigger	SM1548	Block 29	Q4ARCPU QnPRHCPU	○	-
SM1549			SM1549	Block 30			
SM1550			SM1550	Block 31			
SM1551			SM1551	Block 32			
SM1552			SM1552	Block 33			
SM1553			SM1553	Block 34			
SM1554			SM1554	Block 35			
SM1555			SM1555	Block 36			
SM1556			SM1556	Block 37			
SM1557			SM1557	Block 38			
SM1558			SM1558	Block 39			
SM1559			SM1559	Block 40			
SM1560			SM1560	Block 41			
SM1561			SM1561	Block 42			
SM1562			SM1562	Block 43			
SM1563			SM1563	Block 44			
SM1564			SM1564	Block 45			
SM1565			SM1565	Block 46			
SM1566			SM1566	Block 47			
SM1567			SM1567	Block 48			
SM1568			SM1568	Block 49			
SM1569			SM1569	Block 50			
SM1570			SM1570	Block 51			
SM1571			SM1571	Block 52			
SM1572			SM1572	Block 53			
SM1573			SM1573	Block 54			
SM1574			SM1574	Block 55			
SM1575			SM1575	Block 56			
SM1576			SM1576	Block 57			
SM1577			SM1577	Block 58			
SM1578	SM1578	Block 59					
SM1579	SM1579	Block 60					
SM1580	SM1580	Block 61					
SM1581	SM1581	Block 62					
SM1582	SM1582	Block 63					
SM1583	SM1583	Block 64					
SM1590	Switching status from the network module	OFF : Normal ON : Switching unsuccessful	• Turns ON when switching could not be executed normally if the network module had detected a network fault and issued a switching request to the host CPU module.	Q4ARCPU	△	For the QnPRHCPUs, SM1590 turns ON if system switching cause occurs from the MELSECNET/H module or Ethernet module, regardless of whether the switching succeeds. Review the program.	
	System switching enable/disable flag from network module	OFF : System switching request issuing module absent ON : System switching request issuing module present	• Turns ON when a system switching request is issued from the network module. The module No. that issued system switching can be checked by SD1590. • Turns OFF when all bits of SD1590 are OFF.	QnPRHCPU	New	-	
SM1591	Standby system error detection disable flag at system switching	ON : Error is not detected by new standby system at system switching OFF : Error is detected by new standby system at system switching	This flag is used to determine if the new standby system detects an error:STANDBY (error code:6210) during system switching. This applies to the following switching methods: • System switching from GX Developer • System switching using the System switching instruction • System switching request from network module	QnPRHCPU	New	-	
SM1592	Manual switching enable flag	OFF : Disable manual switching ON : Enable manual switching	• This flag enables system switching by the user from GX Developer or by the System switching instruction. (SP.CONTSW).				

○ : Compatible △ : Partial change required × : Not compatible

Number	Name	Description	Explanation	Corresponding CPU	Compatibility	Precautions for replacement
SM1593	Setting to access extension base unit of standby system CPU	OFF : Error ON : Ignored	Sets the operation for the case accessing buffer memory of the intelligent function module mounted on the extension base unit from the standby system CPU in separate mode. OFF : "OPERATION ERROR" (error code: 4112) will be returned when accessing buffer memory of the intelligent function module on the extension base unit from the standby system CPU. ON : No processing is performed when accessing buffer memory of intelligent function module on the extension base unit from the standby system CPU.	QnPRHCPU*2	New	-
SM1595	Memory copy from control system to standby system start flag	OFF : Copy start request ON : Copy not started	<ul style="list-style-type: none"> When SM1595 is turned from OFF to ON, memory copy from control system to standby system starts. Note that when SM1595 is turned from OFF to ON, memory copy does not start if the I/O No. of the copy destination (standby system CPU module: 3D1H) is not stored in SD1595. 	QnPRHCPU	New	-
SM1596	Memory copy to other system status flag	OFF : Memory copy not executed ON : Memory copy executed	<ul style="list-style-type: none"> Turns on while memory is copied from control system to standby system. Turns off when memory copy execution has completed. 			
SM1597	Memory copy to other system complete flag	OFF : Memory copy not completed ON : Memory copy completed	<ul style="list-style-type: none"> Turns on when the memory has copied from control system to standby system. 			
SM1598	Copy contents of standard ROM during memory copy flag	OFF : Copy standard ROM data ON : Standard ROM data is not copied	<ul style="list-style-type: none"> Turns on when the standard ROM data is not copied while memory of the control system is copied to that of the standby system. 			

*2: The module whose first 5 digits of serial No. is 09012 or later.

(3) For redundant system (Another system CPU information *1)

SM1600 to SM1650 only valid for the CPU redundant system backup mode, so they cannot be refreshed during the separate mode.

Either the backup mode or the separate mode is valid for the SM4651 to SM1699.

SM1600 to SM1699 are all turned off for stand-alone system.

○ : Compatible △ : Partial change required × : Not compatible

Number	Name	Description	Explanation	Corresponding CPU	Compatibility	Precautions for replacement
SM1600	Diagnostic error	OFF : No error ON : Error	<ul style="list-style-type: none"> Turns on if an error occurs in the diagnostic results. (Including external diagnostics) Remains on even if returns to normal thereafter. 	Q4ARCPU	△	SM1600 to SM1616 of the Q4ARCPU are equivalent to SM1610 to SM1626 of the QnPRHCPU. Review the program.
SM1601	Self-diagnostic error	OFF : No self-diagnostic error ON : Self-diagnostic error	<ul style="list-style-type: none"> Turns on when an error occurs in the self-diagnostic results. Remains on even if returns to normal thereafter. 			
SM1605	Common error information	OFF : No common error information ON : Common error information	<ul style="list-style-type: none"> Turns on when there is common error information and the SM1600 is on. 			
SM1616	Individual error information	OFF : No individual error information ON : Individual error information exists	<ul style="list-style-type: none"> Turns on when there is individual error information and the SM1600 is on. 			
SM1600	Another system error flag	OFF : No error ON : Error	<ul style="list-style-type: none"> Turns on when an error occurs during redundant system. Error check (Turns on single bit of SD1600.) Is off when no errors are present 	QnPRHCPU	New	-
SM1610	Another system diagnostic error	OFF : No error ON : Error	<ul style="list-style-type: none"> Turns on when a diagnostic error occurs in another system. (Includes error detection when annunciator is ON, and by CHK instruction) Corresponds to status of SM0 at another system. 			
SM1611	Another system self-diagnostic error	OFF : No self-diagnostic error occurred ON : Self-diagnostic error occurred	<ul style="list-style-type: none"> Turns on when a self-diagnostic error occurs in another system. (Does not include error detection when annunciator is ON, and by CHK instruction) Corresponds to status of SM1 at another system. 			
SM1615	Another system common error information	OFF : No common information ON : Common information exists	<ul style="list-style-type: none"> Turns on when there is common error information at another system. Corresponds to status of SM5 at another system. 			
SM1626	Another system individual error information	OFF : No individual error information present ON : Individual error information present	<ul style="list-style-type: none"> Turns on when there is individual error information at another system. Corresponds to status of SM16 at another system. 			
SM1649	Standby system cancel error flag	OFF to ON: Cancels error of standby system	<p>By turning this relay from OFF to ON, the continuation error that occurred in the standby system CPU module can be canceled.</p> <p>Use SD1649 to specify the error code of the error to be canceled.</p>			
SM1653	STOP contact	STOP status	<ul style="list-style-type: none"> Turns on when in the STOP status. 	Q4ARCPU	△	SD1650 of the QnPRHCPU can monitor the CPU status in another system. Review the program.
SM1654	PAUSE contact	PAUSE status	<ul style="list-style-type: none"> Turns on when in the PAUSE status. 			
SM1655	STEP-RUN contact	STEP-RUN status	<ul style="list-style-type: none"> Turns on when in the STEP-RUN status. 			

*1: Stores another system CPU diagnostic information and system information.

(4) For redundant system (tracking)

Either the backup mode or the separate mode is valid for SM1700 to SM1799.

All is turned off for stand-alone system.

○ : Compatible △ : Partial change required × : Not compatible

Number	Name	Description	Explanation	Corresponding CPU	Compatibility	Precautions for replacement
SM1700	Tracking execution flag	OFF : Execution not possible ON : Execution possible	<ul style="list-style-type: none"> Turns on when tracking can be normally executed. 	Q4ARCPU	×	SM1600 of the QnPRHCPU judges whether another system is error. Review the program.
	Transfer trigger complete flag	OFF : Transfer not completed ON : Transfer completed	<ul style="list-style-type: none"> Turns on for one scan, once transfer of block 1 to block 64 is completed. 			
SM1709	User switching disable/enable setting during online program change for redundancy	ON : User switching enabled (Disable canceled) OFF : User switching disabled	<ol style="list-style-type: none"> Turning this relay from OFF to ON enables user switching during online program change for redundancy. After the user switching disable status is canceled, the system automatically turns off SM1709. System switching due to any of the following causes is executed even during online program change for redundancy, regardless of the status of this relay. <ul style="list-style-type: none"> Power-off, reset, hardware failure, CPU stop error In either of the following statuses, the system switching disable status can also be canceled by this relay. <ul style="list-style-type: none"> Multiple-block online program change for redundancy is in execution. File batch online program change for redundancy is in execution. 	QnPRHCPU	New	-
SM1710	Transfer tracking device memory during online program change for redundancy enable flag	OFF : No device memory tracking transfer ON : Perform device memory tracking transfer	<ol style="list-style-type: none"> Set whether tracking transfer of the following control data will be executed or not during online program change for redundancy. <ul style="list-style-type: none"> Device memory (Including SM/SD that automatically performs tracking transfer) PIDINIT information, S.PIDINIT information, SFC information SM1710 can be also used to set whether tracking transfer will be executed or not while online program change for redundancy of multiple blocks or batch of files is being performed to ensure consistency of both systems. This SM1710 is also tracked from control system CPU module to standby system CPU module by tracking transfer. 			

○ : Compatible △ : Partial change required × : Not compatible

Number	Name	Description	Explanation		Corresponding CPU	Compatibility	Precautions for replacement		
SM1712	Transfer trigger complete flag	OFF : Transfer not completed ON : Transfer completed	SM1712	Block1	<In the case of Q4ARCPU> Turns ON only during one scan when the transfer of the corresponding data is completed.	Q4ARCPU QnPRHCPU	○	-	
SM1713			SM1713	Block2					
SM1714			SM1714	Block3					
SM1715			SM1715	Block4					
SM1716			SM1716	Block5					
SM1717			SM1717	Block6					
SM1718			SM1718	Block7					
SM1719			SM1719	Block8					
SM1720			SM1720	Block9					
SM1721			SM1721	Block10					
SM1722			SM1722	Block11					
SM1723			SM1723	Block12					
SM1724			SM1724	Block13					
SM1725			SM1725	Block14					
SM1726			SM1726	Block15					
SM1727			SM1727	Block16					
SM1728			SM1728	Block17					
SM1729			SM1729	Block18					
SM1730			SM1730	Block19					<In the case of QnPRHCPU> Turns ON only during one scan when the transfer of the corresponding block is completed.
SM1731			SM1731	Block20					
SM1732			SM1732	Block21					
SM1733			SM1733	Block22					
SM1734			SM1734	Block23					
SM1735			SM1735	Block24					
SM1736			SM1736	Block25					
SM1737			SM1737	Block26					
SM1738			SM1738	Block27					
SM1739			SM1739	Block28					
SM1740			SM1740	Block29					
SM1741			SM1741	Block30					
SM1742			SM1742	Block31					
SM1743			SM1743	Block32					
SM1744			SM1744	Block33					
SM1745			SM1745	Block34					
SM1746			SM1746	Block35					

○ : Compatible △ : Partial change required × : Not compatible

Number	Name	Description	Explanation		Corresponding CPU	Compatibility	Precautions for replacement	
SM1747	Transfer trigger complete flag	OFF : Transfer not completed ON : Transfer completed	SM1747	Block36	<In the case of Q4ARCPU> Turns ON only during one scan when the transfer of the corresponding data is completed. <In the case of QnPRHCPU> Turns ON only during one scan when the transfer of the corresponding block is completed.	Q4ARCPU QnPRHCPU	○	-
SM1748			SM1748	Block37				
SM1749			SM1749	Block38				
SM1750			SM1750	Block39				
SM1751			SM1751	Block40				
SM1752			SM1752	Block41				
SM1753			SM1753	Block42				
SM1754			SM1754	Block43				
SM1755			SM1755	Block44				
SM1756			SM1756	Block45				
SM1757			SM1757	Block46				
SM1758			SM1758	Block47				
SM1759			SM1759	Block48				
SM1760			SM1760	Block49				
SM1761			SM1761	Block50				
SM1762			SM1762	Block51				
SM1763			SM1763	Block52				
SM1764			SM1764	Block53				
SM1765			SM1765	Block54				
SM1766			SM1766	Block55				
SM1767			SM1767	Block56				
SM1768			SM1768	Block57				
SM1769			SM1769	Block58				
SM1770			SM1770	Block59				
SM1771			SM1771	Block60				
SM1772			SM1772	Block61				
SM1773			SM1773	Block62				
SM1774			SM1774	Block63				
SM1775	SM1775	Block64						

(5) Redundant power supply module information

○ : Compatible △ : Partial change required × : Not compatible

Number	Name	Description	Explanation	Corresponding CPU	Compatibility	Precautions for replacement
SM1780	Power supply off detection flag	OFF : No redundant power supply module with input power supply OFF detected ON : Redundant power supply module with input power supply OFF detected	<ul style="list-style-type: none"> • Turns ON when one or more redundant power supply modules with input power supply OFF are detected. • Turns on if any of SD1780 bits is on. • Turns off if all bits of SD1780 are off. • Turns OFF when the main base unit is not the redundant main base unit (Q38RB). 	QnPRHCPU	New	-
SM1781	Power supply failure detection flag	OFF : No faulty redundant power supply module detected ON : Faulty redundant power supply module detected	<ul style="list-style-type: none"> • Turns ON when one or more faulty redundant power supply modules are detected. • Turns on if any of SD1781 bits is on. • Turns off if all bits of SD1781 are off. • Turns OFF when the main base unit is not the redundant main base unit (Q38RB). 	QnPRHCPU	New	-
SM1782	Momentary power failure detection flag for power supply 1 *1	OFF : No momentary power failure detected ON : Momentary power failure detected	<ul style="list-style-type: none"> • Turns ON when a momentary power failure of the input power supply to the power supply 1 or 2 is detected one or more times. After turning ON, remains ON even if the power supply recovers from the momentary power failure. • Turns OFF the flag (SM1782, SM1783) of the power supply 1/2 when the CPU module starts. • When the input power supply to one of the redundant power supply modules turns OFF the corresponding flag turns OFF. • Turns OFF when the main base unit is not the redundant main base unit (Q38RB). 	QnPRHCPU	New	-
SM1783	Momentary power failure detection flag for power supply 2 *1					

*1: The "power supply 1" indicates the redundant power supply module mounted on the POWER 1 slot of the redundant base unit (Q38RB/Q68RB/Q65WRB).
 The "power supply 2" indicates the redundant power supply module mounted on the POWER 2 slot of the redundant base unit (Q38RB/Q68RB/Q65WRB).

6 SPECIAL REGISTERS

When replacing the Q4ARCPUs with the QnPRHCPUs by "Change PLC type" on GX Developer, the special registers are converted into the same numbers.

However, some special registers are not compatible with the Q4ARCPU or QnPRHCPU.

When using the incompatible special registers, review the program and correct it if necessarily.

(1) Redundant CPU information (own system CPU information*1)

○ : Compatible △ : Partial change required × : Not compatible

Number	Name	Description	Explanation	Corresponding CPU	Compatibility	Precautions for replacement
SD952	History of memory copy from control system to standby system	Latest status of memory copy from control system to standby system	Stores the completion status of the memory copy from control system to standby system executed last. 1) Stores the same value as stored into SD1596 at normal completion/abnormal completion of the memory copy from control system to standby system. 2) Backed up for a power failure, this special register holds the status of memory copy from control system to standby system executed last. 3) Cleared to 0 by latch clear operation.	QnPRHCPU	New	-

*1: The host system CPU information is stored.

(2) Process control instructions

○ : Compatible △ : Partial change required × : Not compatible

Number	Name	Description	Explanation	Corresponding CPU	Compatibility	Precautions for replacement
SD1500 SD1501	Basic period	Basic period time	<ul style="list-style-type: none"> Set the basic period (1 second units) use for the Process control instruction using floating point data. Floating point data = <input type="text" value="SD1501"/> <input type="text" value="SD1500"/>	Q4ARCPU QnPRHCPU	○	-
SD1502	Process control instruction detail error code	Process control instruction detail error code	<ul style="list-style-type: none"> Shows the detailed error contents for the error that occurred in the Process control instruction. 			
SD1503	Process control instruction generated error location	Process control instruction generated error location	<ul style="list-style-type: none"> Shows the error process block that occurred in the Process control instruction. 			
SD1506 SD1507	Dummy device	Dummy device	<ul style="list-style-type: none"> Used to specify dummy devices by a Process control instruction. 			
SD1508	Process control instruction function selection	b0 Bumpless switching function of PIDP control 0: Enable 1: Disable (default: 0)	<ul style="list-style-type: none"> Select whether to enable each function with the Process control instruction. SD1508 <input type="text" value="0"/> <input type="text" value="0"/> <input type="text" value="0"/> <input type="text" value="0"/> <div style="margin-left: 100px;"> b15 b14 to b2 b1 b0 ↑ Enable/disable of bumpless switching function of PIDP control </div>			

(3) For redundant system (host system CPU information *1)

SD1510 to SD1599 are only valid for redundant system.
They are all set to 0 for stand-alone systems.

○ : Compatible △ : Partial change required × : Not compatible

Number	Name	Description	Explanation	Corres-ponding CPU	Compati-bility	Precautions for replacement
SD1512	Operation mode during CPU module start up	Hot start switch power out time	<ul style="list-style-type: none"> Shows the power out time (S) during the automatic switch from hot start to initial start in the operation mode when the CPU module is started up. 	Q4ARCPU	×	The QnPRHCPU always starts with hot start mode independent of power failure time. Review the program.
SD1585	Redundant system LED status	4 LED states <ul style="list-style-type: none"> BACKUP CONTROL SYSTEM A SYSTEM B 	The LED status for BACKUP, CONTROL, SYSTEM A, SYSTEM B is stored in the following format: <div style="text-align: center;"> </div>	QnPRHCPU	New	-
SD1588	System switching cause	System switching cause that occurred in host station	<ul style="list-style-type: none"> Stores the system switching cause on the host system. The following values are stored corresponding to the methods for system switching cause: Initialized to 0 when the power supply is switched off and then on or the RESET switch is set to the RESET position and then to the neutral position. 0 : Initial value (control system has not been switched) 1 : Hardware failure or watchdog timer error 2 : Stop error (except watchdog timer error) 3 : System switching request from network module 16 : System switching instruction 17 : System switching request from GX Developer 	QnPRHCPU	New	-
SD1589	System switching failure cause	System switching failure cause number	<ul style="list-style-type: none"> Stores the system switching cause failure. 0 : System switching normal completion (default) 1 : Tracking cable is not connected , tracking cable error, FPGA circuit failure. 2 : Hardware failure, power-OFF, reset, watchdog timer error on the standby system 3 : Hardware failure, power-OFF, reset, watchdog timer error on the control system 4 : Tracking communication is in preparation. 5 : Communication timeout 6 : Stop error (except watchdog timer error) on the standby system 7 : There is difference between both systems. (detected as backup mode only) 8 : During memory copy from control system to standby system 9 : During online program change 10 : During detection of network module failure on the standby system 11 : System switching being executed Resets to "0" when host system is powered on. Resets to "0" once system has been switched successfully. 	QnPRHCPU	New	-

*1: The information of the host CPU module is stored.

○ : Compatible △ : Partial change required × : Not compatible

Number	Name	Description	Explanation	Corresponding CPU	Compatibility	Precautions for replacement
SD1590	Switching request network No.	Request source network No.	<ul style="list-style-type: none"> Stores the request source at work No. when the SM1590 is turned on. 	Q4ARCPU	△	For the QnPRHCPUs, a bit of the corresponding module number turns ON if system switching cause occurs from the MELSECNET/H module or Ethernet module, regardless of whether the switching succeeds. Review the program.
	Network module head address, which requested system switching	Network module head address, which requested system switching	<ul style="list-style-type: none"> Stores head address of network module which a system switching request was initiated. Turns off automatically by system, after network error is reset by user. <ul style="list-style-type: none"> Please refer to SD1690 which stores the corresponding head address of network module on another system. 	QnPRHCPU		
SD1595	Memory copy target I/O number	Memory copy target I/O number	<ul style="list-style-type: none"> Stores the memory copy target I/O No. (standby system CPU module: 3D1H) of before SM1595 is turned from OFF to ON. 	QnPRHCPU		
SD1596	Memory copy status	Memory copy status	<ul style="list-style-type: none"> Stores the memory copy status. <ul style="list-style-type: none"> 0 : Memory copy successfully completed 4241H: Standby system power supply off 4242H: Tracking cable is disconnected or is damaged 4247H: Memory copy function is being executed 4248H: Unsupported memory copy destination I/O Number 	QnPRHCPU	New	-

(4) For redundant system (another system CPU information *1)

SD1600 to SD1650 is only valid during the backup mode for redundant system, and refresh cannot be done when in the separate mode.

SD1651 to SD1699 are valid in either the backup mode or separate mode.

When a stand-alone system SD1600 to SD1699 are all 0.

○ : Compatible △ : Partial change required × : Not compatible

Number	Name	Description	Explanation	Corresponding CPU	Compatibility	Precautions for replacement
SD1600	Diagnostic error	Diagnostic error No.	<ul style="list-style-type: none"> Stores as BIN code the error code of the error that occurred during the another system CPU module diagnostics. Stores the latest error currently occurring. 	Q4ARCPU	△	SD1600 to SD1626 of the Q4ARCPU are equivalent to SD1610 to SD1636 of the QnPRHCPU. Review the program.
SD1601	Diagnostic error occurrence time	Diagnostic error occurrence time	<ul style="list-style-type: none"> SD1600 stores the updated date and time. Stores each of the BCD two digits. Refer to SD1 to SD3 for the storage status. (SD1 →SD1601, SD2 →SD1602, SD3 →SD1603) 			
SD1602						
SD1603						
SD1604	Error information category	Error information category	<ul style="list-style-type: none"> Stores the common error information/individual error information classification code. Refer to SD4 for the storage status. 			
SD1605	Common error information	Common error information	<ul style="list-style-type: none"> Stores the common information for the error code. Refer to SD5 to SD15 for the storage status. (SD5 →SD1605, SD6 →SD1606, SD7 →SD1607, SD8 →SD1608, SD9 →SD1609, SD10 →SD1610, SD11 →SD1611, SD12 →SD1612, SD13 →SD1613, SD14 →SD1614, SD15 →SD1615) 			
SD1606						
SD1607						
SD1608						
SD1609						
SD1610						
SD1611						
SD1612						
SD1613						
SD1614						
SD1615						
SD1616	Individual error information	Individual error information	<ul style="list-style-type: none"> Stores the individual information for the error code. Refer to SD16 to SD26 for the storage status. (SD16 →SD1616, SD17 →SD1617, SD18 →SD1618, SD19 →SD1619, SD20 →SD1620, SD21 →SD1621, SD22 →SD1622, SD23 →SD1623, SD24 →SD1624, SD25 →SD1625, SD26 →SD1626) 			
SD1617						
SD1618						
SD1619						
SD1620						
SD1621						
SD1622						
SD1623						
SD1624						
SD1625						
SD1626						
SD1650	Switch status	CPU module switch status	<ul style="list-style-type: none"> Stores the CPU module switch status. Refer to SD200 for the storage status. (SD1650 →SD200) 	×	The QnPRHCPU does not have this function. Review the program.	
SD1651	LED status	CPU module LED status	<ul style="list-style-type: none"> Stores the CPU module's LED status. Shows 0 when turned off, 1 when turned on, and 2 when flashing. Refer to SD201 for the storage status. (SD1651 →SD201) 	×	The QnPRHCPU does not have this function. Review the program.	
SD1653	CPU module operating status	CPU module operating status	<ul style="list-style-type: none"> Stores the CPU module operating status. Refer to SD203 for the storage status. (SD1653 →SD203) 	△	SD1650 of the QnPRHCPU can monitor the CPU status in another system. Review the program.	

*1 : Stores another system CPU module diagnostic information and system information.

○ : Compatible △ : Partial change required × : Not compatible

Number	Name	Description	Explanation	Corresponding CPU	Compatibility	Precautions for replacement
SD1600	System error information	System error information	<ul style="list-style-type: none"> If an error is detected by the error check for redundant system, the corresponding bit shown below turns ON. That bit turns OFF when the error is cleared after that. <ul style="list-style-type: none"> If any of b0, b1, b2 and b15 is ON, the other bits are all OFF. In the debug mode, b0, b1, b2 and b15 are all OFF. 			
SD1601	System switching result	System switching results	<ul style="list-style-type: none"> Stores the reasons for system switching. Stores system switching cause into SD1601 of both systems when system switching occurs. Initialized to 0 at power-OFF to ON/reset to unreset. The following shows values stored into this register. <ul style="list-style-type: none"> 0 : Initial value (System switching has not occurred) 1 : Power-OFF, reset, hardware failure, watchdog timer error.(*) 2 : Stop error (except watchdog timer error) 3 : System switching request from network module 16: System switching instruction 17: System switching request from GX Developer *: When the system is switched by the power-OFF/reset of the control system, "1" is not stored into SD1601 of the new standby system. 	QnPRHCPU	New	-
SD1602	System switching instruction parameter	System switching instruction parameter	<ul style="list-style-type: none"> Stores the parameters for system switching dedicated instruction SP.CONTSW. (The parameters (SD1602) for the SP.CONTSW instruction are stored in both systems) SD1602 is only valid when "16: System switching instruction" is stored in SD1601. This SD1602 is updated once the System switching instruction SP.CONTSW is activated. 			
SD1610	Another system diagnostic error	Diagnostic error code	<ul style="list-style-type: none"> An error code of the error occurred at another system sorted in BIN code. Stores SD0 of the another system CPU module switching. 			
SD1611	Another system diagnostic error occurrence time	Diagnostic error occurrence time	<ul style="list-style-type: none"> Stores the date and time when an error occurred at another system. Data format is the same as SD1 to SD3. Also, stores the value to SD1 to SD3 of CPU module on another system. 			
SD1612						
SD1613						
SD1614	Another system error information category	Error information category code	<ul style="list-style-type: none"> Stores the category code corresponding to the common error information/ individual error information code of another system. Data format is the same as SD4. Also, stores the value to SD4 of CPU module on another system. 			
SD1615 to SD1625	Another system common error information	Common error information	<ul style="list-style-type: none"> Stores the common error information of another system. Data composition is the same as SD5 to SD15. Also, stores the value to SD5 to SD15 of CPU module on another system. 			
SD1626 to SD1636	Another system individual error information	Individual error information	<ul style="list-style-type: none"> Stores the individual error information of another system. Data composition is the same as SD16 to SD26. Also, stores the value to SD16 to SD26 of CPU module on another system. 			
SD1649	Standby system error cancel command	Error code of error to be cleared	<ul style="list-style-type: none"> Stores the error code of the error to be cleared by clearing a standby system error. Stores the error code of the error to be cleared into this register and turn SM1649 from OFF to ON to clear the standby system error. The value in the lowest digit (1 place) of the error code is ignored when stored into this register. (By storing 4100 in this register and resetting the error, errors 4100 to 4109 can be cleared.) 			

○ : Compatible △ : Partial change required × : Not compatible

Number	Name	Description	Explanation	Corresponding CPU	Compatibility	Precautions for replacement
SD1650	Another system operating information	Another system operating information	<p>Stores the operation information of another system CPU module in the following format.</p> <p>"00FFH" is stored when an error occurs in communications with another system, or when in debug mode.</p> <p style="text-align: center;">b15 to b8 b7 to b4 b3 to b0</p> <p>SD1650 0</p> <div style="display: flex; justify-content: space-around; margin-top: 10px;"> <div style="border: 1px solid black; padding: 5px; width: 40%;"> <p>0: No error 1: Continuation error 2: Stop error F: Communication with other system disabled (*)</p> </div> <div style="border: 1px solid black; padding: 5px; width: 40%;"> <p>0: RUN 2: STOP 3: PAUSE F: Communication with other system disabled (*)</p> </div> </div> <p style="margin-left: 150px;">*: Communication with another system disabled, debug mode</p> <p>Note : A communication error is caused by the following:</p> <ul style="list-style-type: none"> • When the power supply is off, or when the another system is reset. • Hardware failure error occurs on either of own system or another system. • Watchdog timer error occurs in either. • Tracking cable is not connected. • Tracking cable is disconnected or faulty. 	QnPRHCPU	New	-
SD1690	Network module head address, which requested system switching on another system	Network module head address, which requested system switching on another system	<ul style="list-style-type: none"> • Stores another system network module which a system switching request was issued, using the following format. • Turns off automatically by system, after network error is reset by user. <p style="text-align: center;">b15 to b11 to b1 b0</p> <p>SD1690 0 0/1 ... 0/1 0</p> <p style="margin-left: 100px;">Each bit 0: OFF 1: ON</p> <div style="margin-left: 100px;"> <p>Module 0: CPU module is invalid as it is 2-slot model</p> <p>Module 1: Module on the right side of the CPU module</p> <p style="margin-left: 20px;">to</p> <p>Module 11: Module at the rightmost end of the 12-slot base (Q312B)</p> </div> <ul style="list-style-type: none"> • Please refer to SD1590 which stores the corresponding head address of network module on host system. 			

(5) For redundant system (tracking information)

SD1700 to SD1779 is valid only for redundant system.

These are all 0 for stand-alone systems.

○ : Compatible △ : Partial change required × : Not compatible

Number	Name	Description	Explanation	Corresponding CPU	Compatibility	Precautions for replacement
SD1700	Tracking error detection count	Tracking error detection count	When the tracking error is detected, count is added by one.	Q4ARCPU QnPRHCPU	○	-
SD1710	Waiting time for online program change start (standby system)	Waiting time for online program change start (standby system)	<ul style="list-style-type: none"> Set in seconds the waiting time of the standby system CPU module from when online program change to the control system CPU module is completed by the online program change for redundancy function until the online program change to the standby system CPU module starts. If no online program change request is issued to the standby system CPU module within the preset time after completion of the online program change to the control system CPU module, CPU modules on both systems judge it as the failure of the online program change for redundancy. In this case, CPU modules on both systems resume the identification check between system A and system B suspended during the online program change. Also, the control system CPU module is set to accept a new request of online program change for redundancy. When both systems are powered on, 90 seconds are set to SD1710 as the default value. Set the value within the range 90 to 3600 seconds. When the setting is 0 to 89 seconds, it is regarded as 90 seconds for operation. If the setting is outside the allowed range, it is regarded other than 0 to 3600 seconds for operation. The waiting time for a start of online program change to the standby system CPU module is checked according to the SD1710 setting during online change of multiple blocks and online change of batch of files for redundancy. 	QnPRHCPU	New	-

(6) Redundant power supply module information

SD1780 to SD1789 are valid only for a redundant power supply system.
The bits are all 0 for a singular power supply system.

○ : Compatible △ : Partial change required × : Not compatible

Number	Name	Description	Explanation	Corresponding CPU	Compatibility	Precautions for replacement
SD1780	Power supply off detection status	Power supply off detection status	<ul style="list-style-type: none"> Stores the status of the redundant power supply module (Q64RP) with input power supply OFF in the following bit pattern. Stores 0 when the main base unit is not the redundant power main base unit (Q38RB). 	QnPRHCPU	New	-
SD1781	Power supply failure detection status	Power supply failure detection status	<ul style="list-style-type: none"> Stores the failure detection status of the redundant power supply module (Q64RP) in the following bit pattern. (The corresponding bit is cleared to 0 when the input power supply to the faulty redundant power supply module is switched OFF after detection of the redundant power supply module failure.) Stores 0 when the main base unit is not the redundant power main base unit (Q38RB). 			
SD1782	Momentary power failure detection counter for power supply 1 *1	Momentary power failure detection count for power supply 1	<ul style="list-style-type: none"> Counts the number of times of momentary power failure of the power supply 1/2. Monitors the status of the power supply 1/2 mounted on the redundant power main base unit (Q38RB) and counts the number of times of momentary power failure. Status of power supply 1/power supply 2 mounted on the redundant extension base unit is not monitored. When the CPU module starts, the counter of the power supply 1/2 is cleared to 0. 			
SD1783	Momentary power failure detection counter for power supply 2 *1	Momentary power failure detection count for power supply 2	<ul style="list-style-type: none"> If the input power supply to one of the redundant power supply modules is turned OFF, the corresponding counter is cleared to 0. The counter is incremented by 1 every time the momentary power failure of the power supply 1/2 is detected. (0 to 65535 : When the count exceeds 65535, counting is continued from 0) Stores 0 when the main base unit is not the redundant power main base unit (Q38RB). 			

*1: The "power supply 1" indicates the redundant power supply module mounted on the POWER 1 slot of the redundant base unit (Q38RB/68RB).
The "power supply 2" indicates the redundant power supply module mounted on the POWER 2 slot of the redundant base unit (Q38RB/68RB).

APPENDICES

Appendix 1 Related Manuals

Appendix 1.1 Transition from MELSEC-A/QnA (Large type) series to Q series handbook

No.	Manual name	Manual number	Model code
1	Transition from MELSEC-A/QnA (Large Type) Series to Q Series Handbook (Fundamentals)	L-08043ENG	-
2	Transition from MELSEC-A/QnA (Large Type) Series to Q Series Handbook (Intelligent Function Modules)	L-08046ENG	-
3	Transition from MELSEC-A/QnA (Large Type) Series to Q Series Handbook (Network Modules)	L-08048ENG	-
4	Transition from MELSEC-A/QnA (Large Type) Series to Q Series Handbook (Communications)	L-08050ENG	-

Appendix 1.2 Q4ARCPU

No.	Manual name	Manual number	Model code
1	MELSEC-A/QnA Data Book	L-08025	-
2	Q4ARCPU User's Manual	IB-66685	13J852
3	MELSECNET/10 Network System (for QnA/Q4AR) Reference Manual	IB-66690	13JF78
4	MELSEC Q4ARCPU General Instruction Manual	IB-66745	13J889
5	QnACPU Programming Manual (Fundamentals)	IB-66614	13JF46
6	QnACPU Programming Manual (Special Function Module)	SH-4013	13JF56
7	QCPU(Q Mode)/QnACPU Programming Manual (Common Instructions)	SH-080039	13JF58
8	QCPU(Q Mode)/QnACPU Programming Manual (PID Control Instructions)	SH-080040	13JF59
9	QCPU(Q Mode)/QnACPU Programming Manual (SFC)	SH-080041	13JF60
10	QnACPU Programming Manual (AD57 Instructions)	IB-66617	13JF49
11	Q4ARCPU Programming Manual (Application PID Edition)	IB-66695	13JF52
12	Type MELSECNET, MELSECNET/B Data Link System Reference Manual	IB-66350	13JF70

Appendix 1.3 QnPRHCPU

No.	Manual name	Manual number	Model code
1	MELSEC-Q Catalog	L-08033E	-
2	MELSEC-Q Data Book	L-08029E	-
3	QCPU User's Manual(Hardware Design, Maintenance and Inspection)	SH-080483ENG	13JP73
4	QCPU User's Manual(Function Explanation, Program Fundamentals)	SH-080484ENG	13JP74
5	QCPU(Q Mode)/QnACPU Programming Manual (Common Instructions)	SH-080039	13JF58
6	QCPU(Q Mode)/QnACPU Programming Manual (PID Control Instructions)	SH-080040	13JF59
7	QCPU(Q Mode)/QnACPU Programming Manual (SFC)	SH-080041	13JF60
8	QCPU(Q Mode) Programming Manual (MELSAP-L)	SH-080076	13JF61
9	QnPHCPU/QnPRHCPU Programming Manual (Process Control Instructions)	SH-080316E	13JF67
10	QCPU(Q Mode) Programming Manual (Structured Text)	SH-080366E	13JF68
11	Q Corresponding MELSECNET/H Network System Reference Manual (PLC to PLC network)	SH-080049	13JF92
12	Q Corresponding MELSECNET/H Network System Reference Manual (Remote I/O network)	SH-080124	13JF96

WARRANTY

Please confirm the following product warranty details before using this product.

1. Gratis Warranty Term and Gratis Warranty Range

If any faults or defects (hereinafter "Failure") found to be the responsibility of Mitsubishi occurs during use of the product within the gratis warranty term, the product shall be repaired at no cost via the sales representative or Mitsubishi Service Company. However, if repairs are required onsite at domestic or overseas location, expenses to send an engineer will be solely at the customer's discretion. Mitsubishi shall not be held responsible for any re-commissioning, maintenance, or testing on-site that involves replacement of the failed module.

[Gratis Warranty Term]

The gratis warranty term of the product shall be for one year after the date of purchase or delivery to a designated place.

Note that after manufacture and shipment from Mitsubishi, the maximum distribution period shall be six (6) months, and the longest gratis warranty term after manufacturing shall be eighteen (18) months. The gratis warranty term of repair parts shall not exceed the gratis warranty term before repairs.

[Gratis Warranty Range]

- (1) The range shall be limited to normal use within the usage state, usage methods and usage environment, etc., which follow the conditions and precautions, etc., given in the instruction manual, user's manual and caution labels on the product.
- (2) Even within the gratis warranty term, repairs shall be charged for in the following cases.
 1. Failure occurring from inappropriate storage or handling, carelessness or negligence by the user. Failure caused by the user's hardware or software design.
 2. Failure caused by unapproved modifications, etc., to the product by the user.
 3. When the Mitsubishi product is assembled into a user's device, Failure that could have been avoided if functions or structures, judged as necessary in the legal safety measures the user's device is subject to or as necessary by industry standards, had been provided.
 4. Failure that could have been avoided if consumable parts (battery, backlight, fuse, etc.) designated in the instruction manual had been correctly serviced or replaced.
 5. Failure caused by external irresistible forces such as fires or abnormal voltages, and Failure caused by force majeure such as earthquakes, lightning, wind and water damage.
 6. Failure caused by reasons unpredictable by scientific technology standards at time of shipment from Mitsubishi.
 7. Any other failure found not to be the responsibility of Mitsubishi or that admitted not to be so by the user.

2. Onerous repair term after discontinuation of production

- (1) Mitsubishi shall accept onerous product repairs for seven (7) years after production of the product is discontinued. Discontinuation of production shall be notified with Mitsubishi Technical Bulletins, etc.
- (2) Product supply (including repair parts) is not available after production is discontinued.

3. Overseas service

Overseas, repairs shall be accepted by Mitsubishi's local overseas FA Center. Note that the repair conditions at each FA Center may differ.

4. Exclusion of loss in opportunity and secondary loss from warranty liability

Regardless of the gratis warranty term, Mitsubishi shall not be liable for compensation of damages caused by any cause found not to be the responsibility of Mitsubishi, loss in opportunity, lost profits incurred to the user by Failures of Mitsubishi products, special damages and secondary damages whether foreseeable or not, compensation for accidents, and compensation for damages to products other than Mitsubishi products, replacement by the user, maintenance of on-site equipment, start-up test run and other tasks.

5. Changes in product specifications

The specifications given in the catalogs, manuals or technical documents are subject to change without prior notice.

6. Product application

- (1) In using the Mitsubishi MELSEC programmable controller, the usage conditions shall be that the application will not lead to a major accident even if any problem or fault should occur in the programmable controller device, and that backup and fail-safe functions are systematically provided outside of the device for any problem or fault.
- (2) The Mitsubishi programmable controller has been designed and manufactured for applications in general industries, etc. Thus, applications in which the public could be affected such as in nuclear power plants and other power plants operated by respective power companies, and applications in which a special quality assurance system is required, such as for Railway companies or Public service purposes shall be excluded from the programmable controller applications.

In addition, applications in which human life or property that could be greatly affected, such as in aircraft, medical applications, incineration and fuel devices, manned transportation, equipment for recreation and amusement, and safety devices, shall also be excluded from the programmable controller range of applications.

However, in certain cases, some applications may be possible, providing the user consults their local Mitsubishi representative outlining the special requirements of the project, and providing that all parties concerned agree to the special circumstances, solely at the users discretion.

Ethernet is a registered trademark of Xerox. Co., Ltd in the United States.

Other company and product names herein are either trademarks or registered trademarks of their respective owners.

Mitsubishi Programmable Controller



HEAD OFFICE : TOKYO BUILDING, 2-7-3 MARUNOUCHI, CHIYODA-KU, TOKYO 100-8310, JAPAN
NAGOYA WORKS : 1-14, YADA-MINAMI 5-CHOME, HIGASHI-KU, NAGOYA, JAPAN

When exported from Japan, this handbook does not require application to the Ministry of Economy, Trade and Industry for service transaction permission.