

Mitsubishi Programmable Controller

Transition from MELSEC-AnS/QnAS (Small Type) Series to L Series Handbook

(Communications)



June 2015 Edition

● SAFETY PRECAUTIONS ●

(Read these precautions before using this product.)

Before using this product, please read this handbook and the relevant manuals introduced in this handbook carefully and pay full attention to safety to handle the product correctly.

The precautions given in this handbook are concerned with this product only. For the safety precautions of the programmable controller system, refer to the user's manual for the CPU module used.

In this manual, the safety precautions are classified into two levels: "⚠ WARNING" and "⚠ CAUTION".



Indicates that incorrect handling may cause hazardous conditions, resulting in death or severe injury.



Indicates that incorrect handling may cause hazardous conditions, resulting in minor or moderate injury or property damage.

Under some circumstances, failure to observe the precautions given under "⚠ CAUTION" may lead to serious consequences.

Observe the precautions of both levels because they are important for personal and system safety.

Make sure that the end users read this handbook and then keep the handbook in a safe place for future reference.

[Design Precautions] **WARNING**

- For the operating status of each station after a communication failure, refer to the manuals for the stations used.
Incorrect output or malfunction due to a communication failure may result in an accident.
- To prevent the malfunction of the programmable controller system due to harmful e-mails, take preventive measures (such as antivirus measures) so that the mail server for this module does not receive harmful e-mails.
- To maintain the safety against unauthorized access via the Internet, take measures such as installing a firewall.
- When connecting a peripheral with the CPU module or connecting a personal computer with an intelligent function module to modify data of a running programmable controller, configure an interlock circuit in the program to ensure that the entire system will always operate safely.
For other forms of control (such as program modification or operating status change) of a running programmable controller, read the relevant manuals carefully and ensure that the operation is safe before proceeding.
Especially, when a remote programmable controller is controlled by an external device, immediate action cannot be taken if a problem occurs in the programmable controller due to a communication failure.
To prevent this, configure an interlock circuit in the program, and determine corrective actions to be taken between the external device and CPU module in case of a communication failure.
- Do not write any data to the "system area" of the buffer memory in the intelligent function module.
Also, do not use any "use prohibited" signal as an output signal from the CPU module to the intelligent function module.
Doing so may cause malfunction of the programmable controller system.

[Design Precautions]** CAUTION**

- Do not install the control lines or communication cables together with the main circuit lines or power cables.
Keep a distance of 100mm or more between them.
Failure to do so may result in malfunction due to noise.
- When changing the operating status of the CPU module (such as remote RUN/STOP) from the external device, select "Always wait for OPEN (Communication possible at STOP time)" for the "Initial timing" setting in the network parameter. The communication line will be closed when "Do not wait for OPEN (Communications impossible at STOP time)" is selected and the remote STOP is executed from the external device. Consequently, the CPU module cannot reopen the communication line, and the external device cannot execute the remote RUN.

[Installation Precautions]** WARNING**

- Shut off the external power supply (all phases) used in the system before connecting or disconnecting a module.
Failure to do so may result in electric shock or cause the module to fail or malfunction.

[Installation Precautions]** CAUTION**

- Use the programmable controller in an environment that meets the general specifications in the Safety Guidelines provided with the CPU module or head module.
Failure to do so may result in electric shock, fire, malfunction, or damage to or deterioration of the product.
- To interconnect modules, engage the respective connectors and securely lock the module joint levers until they click. Incorrect interconnection may cause malfunction, failure, or drop of the module.
- Shut off the external power supply (all phases) used in the system before mounting or removing a module. Failure to do so may result in electric shock or cause the module to fail or malfunction.
- Do not directly touch any conductive parts and electronic components of the module.
Doing so can cause malfunction or failure of the module.

[Wiring Precautions]** WARNING**

- Shut off the external power supply (all phases) used in the system before wiring.
Failure to do so may result in electric shock or cause the module to fail or malfunction.
- After installation and wiring, attach the included terminal cover to the module before turning it on for operation.
Failure to do so may result in electric shock.

[Wiring Precautions]

CAUTION

- Use applicable solderless terminals and tighten them within the specified torque range.
If any spade solderless terminal is used, it may be disconnected when a terminal block screw comes loose, resulting in failure.
- Connectors for external devices must be crimped or pressed with the tool specified by the manufacturer, or must be correctly soldered.
Incomplete connections may cause short circuit, fire, or malfunction.
- When connecting a connector with a cable, securely connect the connector part to the module.
- Place the cables in a duct or clamp them.
If not, dangling cable may swing or inadvertently be pulled, resulting in damage to the module or cables or malfunction due to poor contact.
- Check the interface type and correctly connect the cable. Incorrect wiring (connecting the cable to an incorrect interface) may cause failure of the module and external device.
- Tighten the terminal block screws within the specified torque range.
Undertightening can cause short circuit, fire, or malfunction.
Overtightening can damage the screw and/or module, resulting in drop, short circuit, fire, or malfunction.
- When disconnecting the cable from the module, do not pull the cable by the cable part.
For the cable with connector, hold the connector part of the cable.
For the cable connected to the terminal block, loosen the terminal screw.
Pulling the cable connected to the module may result in malfunction or damage to the module or cable.
- Prevent foreign matter such as dust or wire chips from entering the module.
Such foreign matter can cause a fire, failure, or malfunction.
- A protective film is attached to the top of the module to prevent foreign matter, such as wire chips, from entering the module during wiring.
Do not remove the film during wiring.
Remove it for heat dissipation before system operation.

[Startup and Maintenance Precautions]** WARNING**

- Do not touch any terminal while power is on. Doing so will cause electric shock or malfunction.
- Shut off the external power supply (all phases) used in the system before cleaning the module or retightening the terminal block screws.
Failure to do so may result in electric shock.

[Startup and Maintenance Precautions]** CAUTION**

- Do not disassemble or modify the modules. Doing so may cause failure, malfunction, injury, or a fire.
- Shut off the external power supply (all phases) used in the system before connecting or disconnecting a module.
Failure to do so may cause the module to fail or malfunction.
- Tighten the terminal block screws within the specified torque range.
Undertightening can cause drop of the component or wire, short circuit, or malfunction.
Overtightening can damage the screw and/or module, resulting in drop, short circuit, or malfunction.
- After the first use of the product (module, display unit, and terminal block), the number of connections/disconnections is limited to 50 times (in accordance with IEC 61131-2).
Exceeding the limit may cause malfunction.
- Before handling the module, touch a conducting object such as a grounded metal to discharge the static electricity from the human body.
Failure to do so may cause the module to fail or malfunction.

[Operating Precautions]** CAUTION**

- When changing data and operating status, and modifying program of the running programmable controller from a personal computer connected to an intelligent function module, read relevant manuals carefully and ensure the safety before operation.
Incorrect change or modification may cause system malfunction, damage to the machines, or accidents.
- While set values in the buffer memory are being registered to the flash ROM in the module, do not power off the station where the module is mounted or do not reset the CPU module.
Doing so will affect the flash ROM data, and setting to the buffer memory and registration to the flash ROM need to be performed again.
Also, it may cause failure or malfunction of the module.

[Disposal Precautions]** CAUTION**

- When disposing of this product, treat it as industrial waste.

● CONDITIONS OF USE FOR THE PRODUCT ●

- (1) Mitsubishi programmable controller ("the PRODUCT") shall be used in conditions;
 - i) where any problem, fault or failure occurring in the PRODUCT, if any, shall not lead to any major or serious accident; and
 - ii) where the backup and fail-safe function are systematically or automatically provided outside of the PRODUCT for the case of any problem, fault or failure occurring in the PRODUCT.
- (2) The PRODUCT has been designed and manufactured for the purpose of being used in general industries.

MITSUBISHI SHALL HAVE NO RESPONSIBILITY OR LIABILITY (INCLUDING, BUT NOT LIMITED TO ANY AND ALL RESPONSIBILITY OR LIABILITY BASED ON CONTRACT, WARRANTY, TORT, PRODUCT LIABILITY) FOR ANY INJURY OR DEATH TO PERSONS OR LOSS OR DAMAGE TO PROPERTY CAUSED BY the PRODUCT THAT ARE OPERATED OR USED IN APPLICATION NOT INTENDED OR EXCLUDED BY INSTRUCTIONS, PRECAUTIONS, OR WARNING CONTAINED IN MITSUBISHI'S USER, INSTRUCTION AND/OR SAFETY MANUALS, TECHNICAL BULLETINS AND GUIDELINES FOR the PRODUCT.

("Prohibited Application")

Prohibited Applications include, but not limited to, the use of the PRODUCT in;

- Nuclear Power Plants and any other power plants operated by Power companies, and/or any other cases in which the public could be affected if any problem or fault occurs in the PRODUCT.
- Railway companies or Public service purposes, and/or any other cases in which establishment of a special quality assurance system is required by the Purchaser or End User.
- Aircraft or Aerospace, Medical applications, Train equipment, transport equipment such as Elevator and Escalator, Incineration and Fuel devices, Vehicles, Manned transportation, Equipment for Recreation and Amusement, and Safety devices, handling of Nuclear or Hazardous Materials or Chemicals, Mining and Drilling, and/or other applications where there is a significant risk of injury to the public or property.

Notwithstanding the above, restrictions Mitsubishi may in its sole discretion, authorize use of the PRODUCT in one or more of the Prohibited Applications, provided that the usage of the PRODUCT is limited only for the specific applications agreed to by Mitsubishi and provided further that no special quality assurance or fail-safe, redundant or other safety features which exceed the general specifications of the PRODUCTS are required. For details, please contact the Mitsubishi representative in your region.

REVISIONS

* The handbook number is given on the bottom left of the back cover.

Print Date	* Handbook Number	Revision
October, 2012	L(NA)08261ENG-A	First edition
January, 2014	L(NA)08261ENG-B	<p>[Addition]</p> <p>Chapter 3</p> <p>[Partial correction]</p> <p>SAFETY PRECAUTIONS, GENERIC TERMS AND ABBREVIATIONS, Section 1.1, 1.2, 2.2, Appendix 2, 2.2, 2.4, 2.5</p>
June, 2015	L(NA)08261ENG-C	<p>[Change]</p> <p>Chapter 4 → Appendix 1, Appendix 1 → Appendix 2, Appendix 2 → Appendix 3</p> <p>[Partial correction]</p> <p>Section 1.1, 2.2</p>

Japanese Handbook Version L08257-C

This handbook confers no industrial property rights or any rights of any other kind, nor does it confer any patent licenses. Mitsubishi Electric Corporation cannot be held responsible for any problems involving industrial property rights which may occur as a result of using the contents noted in this handbook.

© 2012 MITSUBISHI ELECTRIC CORPORATION

CONTENTS

SAFETY PRECAUTIONS	A - 1
CONDITIONS OF USE FOR THE PRODUCT	A - 6
REVISIONS	A - 7
GENERIC TERMS AND ABBREVIATIONS	A - 11

CHAPTER 1 INTRODUCTION **1 - 1 to 1 - 4**

1.1 Modules Targeted for Replacement	1 - 1
1.2 General Precautions	1 - 4

CHAPTER 2 SERIAL COMMUNICATION MODULE REPLACEMENT **2 - 1 to 2 - 28**

2.1 List of Serial Communication Modules to be Replaced	2 - 1
2.2 Performance Specifications Comparison	2 - 2
2.2.1 Module performance comparison	2 - 2
2.2.2 Cable specifications comparison	2 - 7
2.3 Functional Comparison	2 - 9
2.4 Switch Setting Comparison	2 - 11
2.5 Program Comparison	2 - 14
2.5.1 I/O signal comparison	2 - 14
2.5.2 Buffer memory address comparison	2 - 17
2.6 Reuse of Existing Programs	2 - 20
2.6.1 Reuse of AnS series programs	2 - 20
2.6.2 Reuse of QnAS series programs	2 - 21
2.7 Other Precautions	2 - 22
2.8 Program Examples	2 - 23

CHAPTER 3 ETHERNET INTERFACE MODULE REPLACEMENT **3 - 1 to 3 - 32**

3.1 List of Ethernet Interface Modules to be Replaced	3 - 1
3.2 Performance Specifications Comparison	3 - 2
3.2.1 Module performance comparison	3 - 2
3.2.2 Cable specifications comparison	3 - 5
3.3 Functional Comparison	3 - 6
3.4 Switch Setting Comparison	3 - 10
3.5 Parameter Comparison	3 - 12
3.6 Program Comparison	3 - 13
3.6.1 I/O signal	3 - 13
3.6.2 Buffer memory	3 - 17
3.7 Reuse of Existing Programs	3 - 20
3.8 Other Precaution	3 - 22
3.9 Program Examples	3 - 23

3.9.1	Initial processing	3 - 24
3.9.2	Open/close processing	3 - 26
3.9.3	Communication using fixed buffer	3 - 30

APPENDICES
APPX - 1 to APPX - 4

Appendix 1	External Dimensions	APPX - 1
Appendix 2	Spare Parts Storage	APPX - 1
Appendix 3	Relevant Manuals	APPX - 2
Appendix 3.1	Replacement handbooks	APPX - 2
Appendix 3.2	A series	APPX - 3
Appendix 3.3	AnS series	APPX - 3
Appendix 3.4	QnAS series	APPX - 3
Appendix 3.5	L series	APPX - 3

- For the products shown in handbooks for transition, catalogues, and transition examples, refer to the manuals for the relevant products and check the detailed specifications, precautions for use, and restrictions before replacement.

For the products manufactured by Mitsubishi Electric Engineering Co., Ltd., Mitsubishi Electric System & Service Co., Ltd., and other companies, refer to the catalogue for each product and check the detailed specifications, precautions for use, and restrictions before use.

The manuals and catalogues for our products, products manufactured by Mitsubishi Electric Engineering Co., Ltd., and Mitsubishi Electric System & Service Co., Ltd. are shown in Appendix of each handbook for transition.

- Products shown in this handbook are subject to change without notice.

GENERIC TERMS AND ABBREVIATIONS

Unless otherwise specified, this handbook uses the following generic terms and abbreviations.

Generic term/abbreviation	Description
■ Series	
A series	The abbreviation for large types of Mitsubishi MELSEC-A series programmable controllers
AnS series	The abbreviation for small types of Mitsubishi MELSEC-A series programmable controllers
QnAS series	The abbreviation for small types of Mitsubishi MELSEC-QnA series programmable controllers
Q series	The abbreviation for Mitsubishi MELSEC-Q series programmable controllers
L series	The abbreviation for Mitsubishi MELSEC-L series programmable controllers
■ CPU module type	
CPU module	A generic term for A series, AnS series, QnA series, QnAS series, Q series, and L series CPU modules
■ CPU module model	
ACPU	A generic term for MELSEC-A series CPU modules
AnSCPU	A generic term for MELSEC-AnS series CPU modules
AnNCPUP	A generic term for the A1NCPUP, A1NCPUP21/R21, A1NCPUP21-S3, A2NCPUP, A2NCPUP-S1, A2NCPUP21/R21, A2NCPUP21/R21-S1, A2NCPUP21-S3(S4), A3NCPUP, A3NCPUP21/R21, and A3NCPUP21-S3
AnACPU	A generic term for the A2ACPU, A2ACPU-S1, A3ACPU, A2ACPUP21/R21, A2ACPUP21/R21-S1, and A3ACPUP21/R21
AnUCPU	A generic term for the A2UCPU, A2UCPU-S1, A3UCPU, and A4UCPU
AnUS(H)CPU	A generic term for the A2USCPU, A2USCPU-S1, and A2USHCPU-S1
A/AnSCPU	A generic term for the ACPU and AnSCPU
AnN/AnACPU	A generic term for the AnNCPUP and AnACPU
AnN/AnA/AnSCPU	A generic term for the AnNCPUP, AnACPU, and AnSCPU
QnACPU	A generic term for MELSEC-QnA series CPU modules
QnASCPU	A generic term for MELSEC-QnAS series CPU modules
QCPU	A generic term for MELSEC-Q series CPU modules
LCPU	A generic term for MELSEC-L series CPU modules

1 INTRODUCTION

1.1 Modules Targeted for Replacement

This handbook describes how to replace the following communication modules.

- AnS series computer link module: Refer to CHAPTER 2.
- QnAS series serial communication module: Refer to CHAPTER 2.
- AnS/QnAS series Ethernet interface module: Refer to CHAPTER 3.

(1) Replacing AnS series computer link modules and QnAS series serial communication modules

(a) AnS series computer link modules

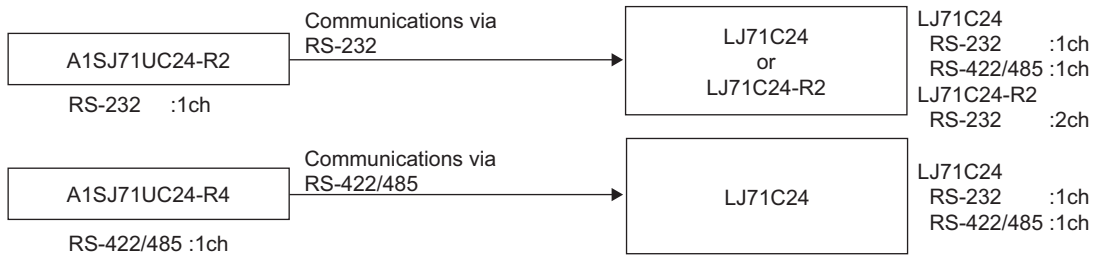

☒ Point

L series communication modules do not have a function equivalent to the multidrop link function of the AnS series communication module, A1SJ71UC24-R4.

Consider replacement to a CC-Link system.

For the replacement method, refer to the Transition from MELSEC-A/QnA (Large Type), AnS/QnAS (Small Type) Series to Q Series Handbook (Communications).

(b) QnAS series serial communication modules

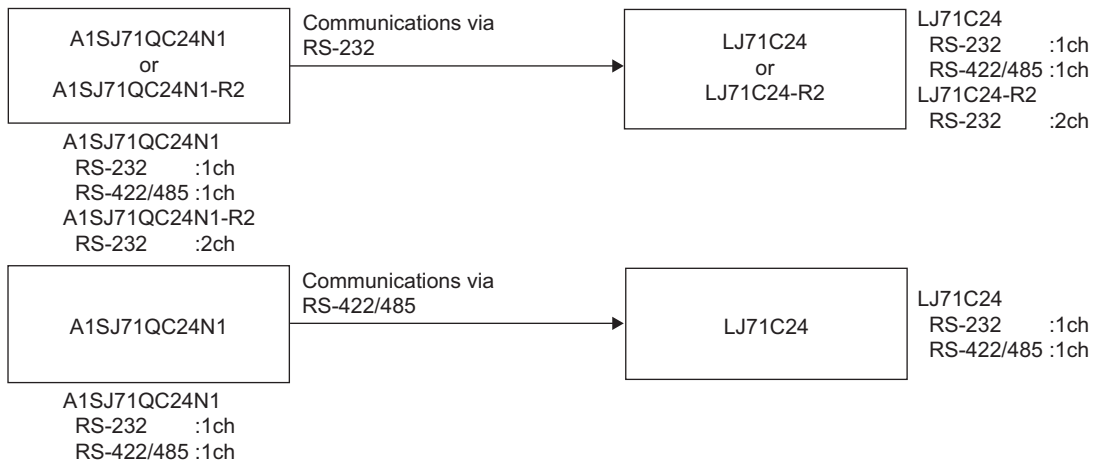

(2) Replacing the AnS series Ethernet interface module and QnAS series Ethernet interface module

(a) AnS series Ethernet interface module

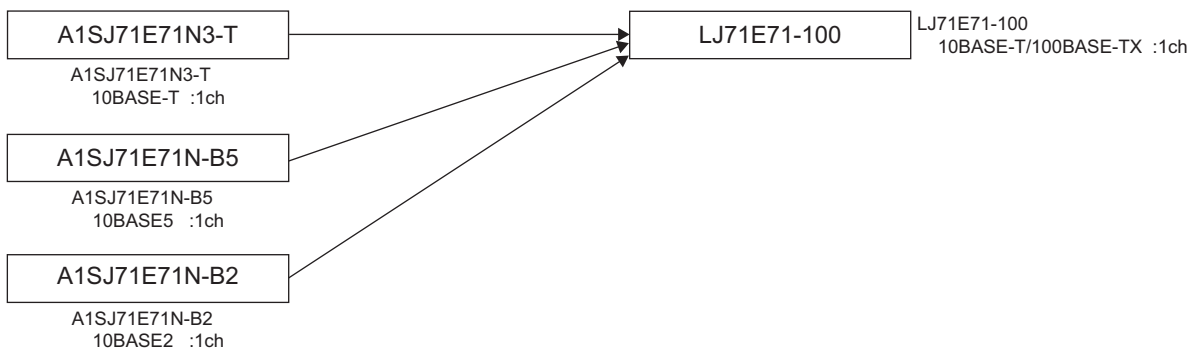

(b) QnAS series Ethernet interface module

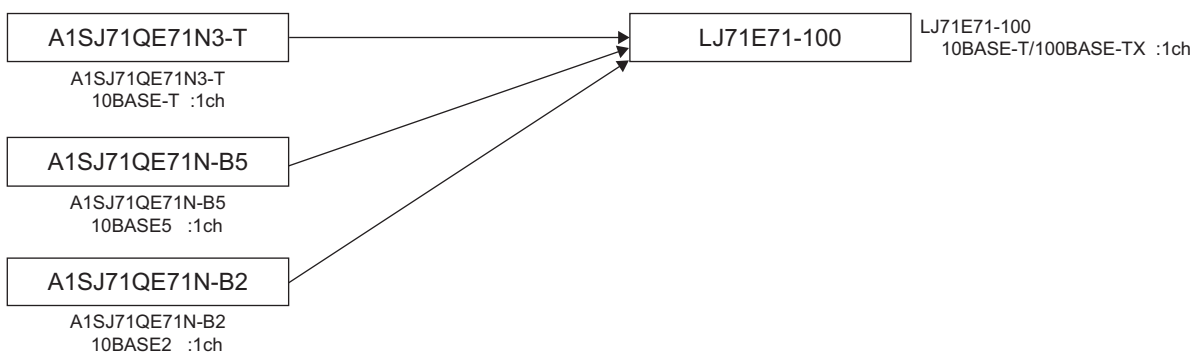

☒ Point

The L series Ethernet interface module does not support 10BASE5 and 10BASE2 of the Ethernet standards.
 Consider converting 10BASE5 and 10BASE2 to the 10BASE-T of the Ethernet standard using a media converter.

(3) Replacing the AnS series intelligent communication module (A1SD51S)

No alternative modules are available in L series. Consider replacement with Q series modules or replacement of a system including external devices and programs.

1.2 General Precautions

(1) Utilizing AnS/QnAS series sequence programs in L series systems

AnS/QnAS series sequence programs can be converted for the use in L series systems using GX Developer. (Note that, with GX Works2, these programs cannot be converted.)
When converting AnS/QnAS series sequence programs to L series ones, use GX Developer.

(2) Creating new L series sequence programs

L series sequence programs can be created using GX Developer or GX Works2.
Use of GX Works2 helps users to make settings (module and communication) and perform debugging easily.

2 SERIAL COMMUNICATION MODULE REPLACEMENT

2.1 List of Serial Communication Modules to be Replaced

(1) AnS series

AnS series	L series alternative model	Remarks
A1SJ71UC24-R2	LJ71C24	A1SJ71UC24-R2 RS-232: 1ch, RS-422/485: None LJ71C24 RS-232: 1ch, RS-422/485: 1ch
	LJ71C24-R2	A1SJ71UC24-R2 RS-232: 1ch, RS-422/485: None LJ71C24-R2 RS-232: 2ch, RS-422/485: None
A1SJ71UC24-R4	LJ71C24	A1SJ71UC24-R4 RS-232: None, RS-422/485: 1ch LJ71C24 RS-232: 1ch, RS-422/485: 1ch
A1SCPUC24-R2 *1	L02CPU + LJ71C24 or LJ71C24-R2	Select a CPU module and serial communication module as alternative models.

*1 This module is the CPU module built in the functions of the A1SJ71C24. The performance specifications of built-in functions are the same as the A1SJ71UC24-R2. For the performance specifications comparison after replacement, read the A1SCPUC24-R2 as the A1SJ71UC24-R2 in Section 2.2.1 (1).

(2) QnAS series

QnAS series model	L series alternative model	Remarks
A1SJ71QC24N1	LJ71C24	A1S71QC24N1 RS-232: 1ch, RS-422/485: 1ch LJ71C24 RS-232: 1ch, RS-422/485: 1ch
A1SJ71QC24N1-R2	LJ71C24-R2	A1S71QC24N1-R2 RS-232: 2ch, RS-422/485: None LJ71C24-R2 RS-232: 2ch, RS-422/485: None

2.2 Performance Specifications Comparison

2.2.1 Module performance comparison

(1) Between AnS series and L series

(a) A1SJ71UC24-R2

○ : Compatible, △ : Partial change required, × : Incompatible

Item		Specifications		Compatibility	Precautions for replacement															
		AnS series	L series																	
		A1SJ71UC24-R2	LJ71C24 LJ71C24-R2																	
Interface	RS-232	RS-232 compliant (9-pin D-sub) 1ch	RS-232 compliant (9-pin D-sub) LJ71C24: 1ch LJ71C24-R2: 2ch	○																
	RS-422/485	-	RS-422/485 compliant (2-piece terminal block) LJ71C24: 1ch LJ71C24-R2: None	-																
Communication method	Communication using dedicated protocol ¹	Half-duplex communication		○																
	Nonprocedural/bidirectional communication	Full-duplex communication (1:1 connection)	Full-duplex communication (1:1 connection) Half-duplex communication (1:n or m:n connection)	○																
Synchronization method		Start stop synchronization (asynchronous method)		○																
Transmission speed		300 to 19200 bps	50 to 230400 bps	○																
Data format	Start bit	1		○																
	Data bit	7 or 8		○																
	Parity bit	1 (vertical parity) or none		○																
	Stop bit	1 or 2		○																
Access cycle	Communication using dedicated protocol	One request is processed during the END processing of the connected CPU module.		○																
	Nonprocedural/bidirectional communication	Data is sent at each send request and is received at any time.		○																
	Communication using communication protocol	-	Upon request by the dedicated instruction (for both transmission and reception)	○																
Error detection	Parity check	Supported (odd/even)/Not supported		○																
	Sum check	Supported (MC protocol/bidirectional)/Not supported	Supported (MC protocol/bidirectional/communication protocol)/Not supported	○																
Transmission control		<table border="1"> <tr> <td></td> <td>RS-232</td> <td>RS-422/485</td> </tr> <tr> <td>DTR/DSR (ER/DR) control</td> <td>Available</td> <td>Not available</td> </tr> <tr> <td>CD signal control</td> <td>Available</td> <td>Not available</td> </tr> <tr> <td>DC1/DC3 (Xon/Xoff) control</td> <td>Available</td> <td>Available</td> </tr> <tr> <td>DC2/DC4 control</td> <td>Available</td> <td>Available</td> </tr> </table>			RS-232	RS-422/485	DTR/DSR (ER/DR) control	Available	Not available	CD signal control	Available	Not available	DC1/DC3 (Xon/Xoff) control	Available	Available	DC2/DC4 control	Available	Available	○	
	RS-232	RS-422/485																		
DTR/DSR (ER/DR) control	Available	Not available																		
CD signal control	Available	Not available																		
DC1/DC3 (Xon/Xoff) control	Available	Available																		
DC2/DC4 control	Available	Available																		
Line configuration (connection)	RS-232	1:1		○																
	RS-422/485	-	1:1, 1:n, n:1, m:n (n: max. 32, m+n: max. 32)	○																

Item		Specifications		Compatibility	Precautions for replacement
		AnS series	L series		
		A1SJ71UC24-R2	LJ71C24 LJ71C24-R2		
Line configuration (data communication)	Communication using dedicated protocol	1:1	1:1, 1:n, m:n (n: max. 32, m+n: max. 32)	○	For details on linked operation between interfaces, refer to the manual for the module used.
	Nonprocedural communication	1:1	1:1, 1:n, or n:1 (n: max. 32)	○	
	Bidirectional communication	1:1		○	
	Communication using communication protocol	-	1:1 or n:1 (n: max. 32)	○	
Transmission distance	RS-232	Max. 15m		○	
	RS-422/485	-	Max. 1200m (overall distance)	○	
Number of writes to E ² PROM and number of writes to flash ROM		Max. 100000 times on the same area in E ² PROM	Max. 100000 times on the same area in flash ROM	○	
Number of occupied I/O points		32 points/slot (I/O assignment: special 32 points)	32 points (I/O assignment: intelli. 32 points)	○	

*1 In the L series, this protocol is called "MELSEC communication protocol" (MC protocol).

(b) A1SJ71UC24-R4

○ : Compatible, △ : Partial change required, × : Incompatible

Item		Specifications		Compatibility	Precautions for replacement															
		AnS series	L series																	
		A1SJ71UC24-R4	LJ71C24																	
Interface	RS-232	-	RS-232 compliant (9-pin D-sub) 1ch	-																
	RS-422/485	RS-422/485 compliant 1ch	RS-422/485 compliant (2-piece terminal block) 1ch	△	Wiring needs to be changed.															
Communication method	Communication using dedicated protocol*1	Half-duplex communication		○																
	Nonprocedural/bidirectional communication	Full-duplex communication (1:1 connection)/ Half-duplex communication (1:n or m:n connection)		○																
Synchronization method		Start stop synchronization (asynchronous method)		○																
Transmission speed		300 to 19200 bps	50 to 230400 bps	○																
Data format	Start bit	1		○																
	Data bit	7 or 8		○																
	Parity bit	1 (vertical parity) or none		○																
	Stop bit	1 or 2		○																
Access cycle	Communication using dedicated protocol	One request is processed during the END processing of the connected CPU module.		○																
	Nonprocedural/bidirectional communication	Data is sent at each send request and is received at any time.		○																
	Communication using communication protocol	-	Upon request by the dedicated instruction (for both transmission and reception)	○																
Error detection	Parity check	Supported (odd/even)/Not supported		○																
	Sum check	Supported (MC protocol/bidirectional)/Not supported		○																
Transmission control		<table border="1"> <thead> <tr> <th></th> <th>RS-232</th> <th>RS-422/485</th> </tr> </thead> <tbody> <tr> <td>DTR/DSR (ER/DR) control</td> <td>Available</td> <td>Not available</td> </tr> <tr> <td>CD signal control</td> <td>Available</td> <td>Not available</td> </tr> <tr> <td>DC1/DC3 (Xon/Xoff) control</td> <td>Available</td> <td>Available</td> </tr> <tr> <td>DC2/DC4 control</td> <td>Available</td> <td>Available</td> </tr> </tbody> </table>			RS-232	RS-422/485	DTR/DSR (ER/DR) control	Available	Not available	CD signal control	Available	Not available	DC1/DC3 (Xon/Xoff) control	Available	Available	DC2/DC4 control	Available	Available	○	
	RS-232	RS-422/485																		
DTR/DSR (ER/DR) control	Available	Not available																		
CD signal control	Available	Not available																		
DC1/DC3 (Xon/Xoff) control	Available	Available																		
DC2/DC4 control	Available	Available																		
Line configuration (connection)	RS-232	-	1:1	○																
	RS-422/485	1:1, 1:n, n:1, m:n (n: max. 32, m+n: max. 32)		○																
Line configuration (data communication)	Communication using dedicated protocol	1:1, 1:n, m:n (n: max. 32, m+n: max. 32)		○	For details on linked operation between interfaces, refer to the manual for the module used.															
	Nonprocedural communication	1:1, 1:n (n: max. 32)	1:1, 1:n, or n:1 (n: max. 32)	○																
	Bidirectional communication	1:1		○																
	Communication using communication protocol	-	1:1 or n:1 (n: max. 32)	○																
Transmission distance	RS-232	-	Max. 15m	○																
	RS-422/485	Max. 500m (overall distance)	Max. 1200m (overall distance)	○																
Number of writes to E ² PROM and number of writes to flash ROM		Max. 100000 times on the same area in E ² PROM	Max. 100000 times on the same area in flash ROM	○																
Number of occupied I/O points		32 points/slot (I/O assignment: special 32 points)	32 points (I/O assignment: intelli. 32 points)	○																

*1 In the L series, this protocol is called "MELSEC communication protocol" (MC protocol).

(2) Between QnAS series and L series

○ : Compatible, △ : Partial change required, × : Incompatible

Item	Specifications		Compatibility	Precautions for replacement																			
	QnAS series	L series																					
	A1SJ71QC24N1 A1SJ71QC24N1-R2	LJ71C24 LJ71C24-R2																					
Interface	RS-232	RS-232 compliant (9-pin D-sub) A1SJ71QC24N1: 1ch A1SJ71QC24N1-R2: 2ch	RS-232 compliant (9-pin D-sub) LJ71C24: 1ch LJ71C24-R2: 2ch	○																			
	RS-422/485	RS-422/485 compliant (2-piece terminal block) A1SJ71QC24N1: 1ch A1SJ71QC24N1-R2: None	RS-422/485 compliant (2-piece terminal block) LJ71C24: 1ch LJ71C24-R2: None	△	Wiring needs to be changed.																		
	Communication using dedicated protocol*1	Half-duplex communication		○																			
	Nonprocedural protocol communication	Full-duplex communication/half-duplex communication		○																			
	Bidirectional protocol communication	Full-duplex communication/half-duplex communication		○																			
	Communication using communication protocol	-	Upon request by the dedicated instruction (for both transmission and reception)	○																			
Synchronization method		Start stop synchronization (asynchronous method)		○																			
Transmission speed		300 to 115200 bps	50 to 230400 bps	○																			
Data format	Start bit	1		○																			
	Data bit	7 or 8		○																			
	Parity bit	1 (vertical parity) or none		○																			
	Stop bit	1 or 2		○																			
Access cycle	Communication using dedicated protocol	Requests are processed during the END processing of the connected CPU module		○																			
	Nonprocedural protocol communication	Data is sent at each send request and is received at any time.		○																			
	Bidirectional protocol communication			○																			
	Communication using communication protocol	-	Upon request by the dedicated instruction (for both transmission and reception)	○																			
Error detection	Parity check	Supported (odd/even)/Not supported		○																			
	Sum check	Supported/Not supported		○	Select the status in parameter or user frame.																		
Transmission control		<table border="1"> <thead> <tr> <th></th> <th>RS-232</th> <th>RS-422/485</th> </tr> </thead> <tbody> <tr> <td>DTR/DSR (ER/DR) control</td> <td>Available</td> <td>Not available</td> </tr> <tr> <td>RS/CS control</td> <td>Available</td> <td>Not available</td> </tr> <tr> <td>CD signal control</td> <td>Available</td> <td>Not available</td> </tr> <tr> <td>DC1/DC3 (Xon/Xoff) control</td> <td>Available</td> <td>Available</td> </tr> <tr> <td>DC2/DC4 control</td> <td>Available</td> <td>Available</td> </tr> </tbody> </table>			RS-232	RS-422/485	DTR/DSR (ER/DR) control	Available	Not available	RS/CS control	Available	Not available	CD signal control	Available	Not available	DC1/DC3 (Xon/Xoff) control	Available	Available	DC2/DC4 control	Available	Available	○	
	RS-232	RS-422/485																					
DTR/DSR (ER/DR) control	Available	Not available																					
RS/CS control	Available	Not available																					
CD signal control	Available	Not available																					
DC1/DC3 (Xon/Xoff) control	Available	Available																					
DC2/DC4 control	Available	Available																					
Line configuration (connection)	RS-232	1:1		○																			
	RS-422/485	1:1, 1:n, m:n (n: max. 32, m+n: max. 32)	1:1, 1:n, n:1, m:n (n: max. 32, m+n: max. 32)																				

Item		Specifications		Compatibility	Precautions for replacement
		QnAS series	L series		
		A1SJ71QC24N1 A1SJ71QC24N1-R2	LJ71C24 LJ71C24-R2		
Line configuration (data communication)	Communication using dedicated protocol	1:1, 1:n, m:n (n: max. 32, m+n: max. 32)		○	For details on linked operation between interfaces, refer to the manual for the module used.
	Nonprocedural protocol communication	1:1, 1:n (n: max. 32)	1:1, 1:n, or n:1 (n: max. 32)	○	
	Bidirectional protocol communication	1:1		○	
	Communication using communication protocol	-	1:1 or n:1 (n: max. 32)	○	
Transmission distance	RS-232	Max. 15m		○	
	RS-422/485	Max. 1200m (overall distance)			
Number of writes to E ² PROM and number of writes to flash ROM		Max. 100000 times on the same area in E ² PROM	Max. 100000 times on the same area in flash ROM	○	
Number of occupied I/O points		32 points/slot (I/O assignment: special 32 points)	32 points (I/O assignment: intelli. 32 points)	○	

*1 In the L series, this protocol is called "MELSEC communication protocol" (MC protocol).

2.2.2 Cable specifications comparison

(1) Between AnS series and L series

○ : Compatible, △ : Partial change required, × : Incompatible

Item	Specifications		Compatibility	Precautions for replacement	
	AnS series	L series			
	A1SJ71UC24-R2 A1SJ71UC24-R4	LJ71C24 LJ71C24-R2			
RS-232	Cable	Use a cable that is compliant with the RS-232 standard.*1		○	
	Cable length	Max. 15m		○	
	Applicable connector for external wiring (module side)	9-pin D-sub (male, screw type) (mating screw M2.6)	9-pin D-sub*2 (male, screw type) (mating screw M2.6)	○	
RS-422/485	Cable	*1		○	
		Item	Description		
		Cable type	Shielded cable		
		Number of pairs	3P		
		Conductor resistance (20 °C)	88.0Ω /km or less		
		Insulation resistance	10000 MΩ -km or higher		
		Dielectric withstand voltage	500VDC for 1 minute		
		Electrostatic capacitance (1kHz)	Average 60nF/km or less		
Characteristic impedance (100kHz)	110±10Ω				
	Cable length	Max. 500m (overall distance)	Max. 1200m (overall distance)	○	
	External wiring (module side)	Connected to terminal block		○	For details on the connection method, refer to the manual for the module used.

*1 The RS-232 and RS-422/485 recommended cables are specified in the MELSEC-L Serial Communication Module User's Manual (Basic).

*2 For the connector shell of the cable connected to the L series serial communication module, use the exclusive products listed in the MELSEC-L Serial Communication Module User's Manual (Basic).

(2) Between QnAS series and L series

○ : Compatible, △ : Partial change required, × : Incompatible

Item	Specifications		Compatibility	Precautions for replacement	
	QnAS series	L series			
	A1SJ71QC24N1 A1SJ71QC24N1-R2	LJ71C24 LJ71C24-R2			
RS-232	Cable	Use a cable that is compliant with the RS-232 standard.*1		○	
	Cable length	Max. 15m		○	
	Applicable connector for external wiring (module side)	9-pin D-sub (male, screw type) (mating screw M2.6)	9-pin D-sub*2 (male, screw type) (mating screw M2.6)	○	
RS-422/485	Cable	*1		○	
		Item	Description		
		Cable type	Shielded cable		
		Number of pairs	3P		
Conductor resistance (20 °C)		88.0Ω /km or less			
Insulation resistance		10000 MΩ ·km or higher			
Dielectric withstand voltage		500VDC for 1 minute			
Electrostatic capacitance (1kHz)		Average 60nF/km or less			
Characteristic impedance (100kHz)	110±10Ω				
Cable length	Max. 1200m (overall distance)		○		
External wiring (module side)	Connected to terminal block		○	For details on the connection method, refer to the manual for the module used.	

*1 The RS-232 and RS-422/485 recommended cables are specified in the MELSEC-L Serial Communication Module User's Manual (Basic).

*2 For the connector shell of any cable connected to the L series serial communication module, use the exclusive products listed in MELSEC-L Serial Communication Module User's Manual (Basic).

2.3 Functional Comparison

(1) Between AnS series and L series

○ : Compatible, △ : Partial change required, × : Incompatible

Item	Description		Compatibility	Precautions for replacement	Reference
	AnS series	L series			
	A1SJ71UC24-R2 A1SJ71UC24-R4	LJ71C24 LJ71C24-R2			
Communication using dedicated protocol*1	Device memory read/write	Reads/writes CPU module data from/to external devices.	△	The applicable commands, accessible device ranges, and access to another station are restricted. The program on the external device side needs to be changed.	Section 2.6.1
	On-demand	Sends data in the CPU module to external devices.	△	Change to a sequence program that uses the dedicated instruction (ONDEMAND).	
Nonprocedural communication	Sending data to external device	Sends data in the CPU module to external devices.	△	Change to a sequence program that uses the dedicated instructions (OUTPUT/INPUT).	
	Receiving data from external device	Receives data sent from external devices to the CPU module.	△		
Bidirectional communication	Sending data to external device	Sends data in the CPU module to external devices.	△	Change to a sequence program that uses the dedicated instructions (BIDOUT/BIDIN).	
	Receiving data from external device	Receives data sent from external devices to the CPU module.	△		
Transmission using printer function		Sends messages (character strings) from the CPU module to the printer.	△	Change to a sequence program that uses the dedicated instruction (PRR). Messages are transmitted by nonprocedural protocol using user frames.	
Transmission control	DTR/DSR control	Controls data transmission/reception with external devices by RS-232 control signals.	○		
	CD control signal		○		
	DC code control	Sends/receives DC codes (including Xon/Xoff) and controls data transmission/reception with external devices.	○		

*1 In the L series, this protocol is called "MELSEC communication protocol" (MC protocol).

(2) Between QnAS series and L series

○ : Compatible, △ : Partial change required, × : Incompatible

Item	Description		Compatibility	Precautions for replacement	Reference
	QnAS series	L series			
	A1SJ71QC24N1 A1SJ71QC24N1-R2	LJ71C24 LJ71C24-R2			
Communication using dedicated protocol*1	Communication in ASCII mode	Performs communications in dedicated protocol using ASCII data.	○		
	Communication in binary mode	Performs communications in dedicated protocol using binary data.	○		
	Device memory read/write	Reads/writes CPU module data from/to external devices.	○		
	Access to another station	Reads/writes data to CPU module on another station in the network system.	○	The program on the PC side may need to be changed depending on the connected network.	
	On-demand	Sends data in the CPU module to external devices.	○		
Nonprocedural protocol communication	Sending/receiving data to/from external device	Sends/receives data between the CPU module and external devices.	○		
	Sending/receiving data in user frames	Sends/receives data in user frames (data registered to the serial communication module).	○		
	Sending/receiving data by ASCII-binary conversion	Converts binary data to ASCII data before it is transmitted, and converts received ASCII data to binary data.	○		
Bidirectional protocol communication	Sending/receiving data to/from external devices	Sends/receives data between the CPU module and external devices.	○		
	Sending/receiving data by ASCII-binary conversion	Converts binary data to ASCII data before it is transmitted, and converts received ASCII data to binary data.	○		
Communication by link dedicated instruction (SEND/RECV, READ/WRITE, REQ)		Sends/receives data to/from the CPU module on another station (multidrop connection) using link dedicated instructions.	-	×	Consider replacement to a CC-Link system. Section 2.6.2
Transmission control	DTR/DSR control	Controls data transmission/reception with external devices by RS-232 control signals.	○		
	RS/CS control		○		
	CD control signal		○		
	DC code control	Sends/receives DC codes (including Xon/Xoff) and controls data transmission/reception with external devices.	○		

*1 In the L series, this protocol is called "MELSEC communication protocol" (MC protocol).

2.4 Switch Setting Comparison

(1) Between AnS series and L series

(a) A1SJ71UC24-R2

○ : Compatible, △ : Partial change required, × : Incompatible

Switch name	Description		Compatibility	Precautions for replacement	Reference	
	AnS series	L series				
	A1SJ71UC24-R2	LJ71C24 LJ71C24-R2				
Mode setting switch	The mode of each interface is set according to the data communication function to be used.		△	△		
	RS-232 (for CH1)					
	0	Use prohibited				
	1	Dedicated protocol (Format 1)				
	to					
	4	Dedicated protocol (Format 4)				
	5	Nonprocedural mode or bidirectional mode				
	6	Use prohibited				
	to					
E	Self-loopback test					
F						
Station number setting switch		-	△	Set the switches in PLC parameters using GX Works2. Refer to (3).	Section 2.7	
Transmission specifications setting switch	SW03	A1ADP-SP setting	-			-
	SW04	Write during RUN setting	-			△
	SW05 to SW07	Transmission speed setting	-			△
	SW08	Data bit setting	-			△
	SW09	Parity bit setting	-			△
	SW10	Even/odd parity setting	-			△
	SW11	Stop bit setting	-			△
	SW12	Sum check setting	-			△

(b) A1SJ71UC24-R4

○ : Compatible, △ : Partial change required, × : Incompatible

Switch name		Description		Compatibility	Precautions for replacement	Reference
		AnS series	L series			
		A1SJ71UC24-R4	LJ71C24 LJ71C24-R2			
Mode setting switch		The mode of each interface is set according to the data communication function to be used.		-	△	Set the switches in PLC parameters using GX Works2. Refer to (3).
		RS-422/485 (for CH2)				
		0	Use prohibited			
		to				
		3				
		4	Nonprocedural mode or bidirectional mode			
		5	Dedicated protocol (Format 1)			
		to				
		8	Dedicated protocol (Format 4)			
		9	Use prohibited			
to						
E						
F	Self-loopback test					
Station number setting switch		The station number of the module is set for data communications using dedicated protocol.		-	△	
Transmission specification switch	SW01	Master station/ Local station setting	The station type for use of multidrop link function is set.	-	-	The L series modules do not support the multidrop link function.
	SW02	Computer link/ multidrop link selection	The function of the computer link unit used is set.	-	-	
	SW03	A1ADP-SP setting	The switch is set to on to use the computer link function by mounting the A1SJ71UC24-R4 to the A1ADP.	-	-	Set the switches in PLC parameters using GX Works2. Refer to (3).
	SW04	Write during RUN enabled/ disabled setting	The enable/disable status of Write during RUN in data communications using dedicated protocol is set.	-	△	
	SW05 to SW07	Transmission speed setting	The transmission speed for data communications is set.	-	△	
	SW08	Data bit setting	The data bit length of the data to be transmitted/received is set.	-	△	
	SW09	Parity bit setting	The parity bit status of the data to be transmitted/received is set.	-	△	
	SW10	Even/odd parity setting	The type of parity bit add to the data to be transmitted/received is set.	-	△	
	SW11	Stop bit setting	The stop bit length of the data to be transmitted/received is set.	-	△	
	SW12	Sum check setting	The sum check code status in data communications using dedicated protocol is set.	-	△	

Section 2.7

(2) Between QnAS series and L series

○ : Compatible, △ : Partial change required, × : Incompatible

Switch name	Description		Compatibility	Precautions for replacement	Reference	
	QnAS series	L series				
	A1SJ71QC24N1 A1SJ71QC24N1-R2	LJ71C24 LJ71C24-R2				
Mode setting switch	The mode of each interface is set according to the data communication function to be used.		-	△		
	0	(For independent operation/linked operation)				
	1	Dedicated protocol (Format 1)				
	2	Dedicated protocol (Format 2)				
	3	Dedicated protocol (Format 3)				
	4	Dedicated protocol (Format 4)				
	5	Dedicated protocol (Format 5)				
	6	Nonprocedural protocol				
	7	Bidirectional protocol				
	8	Setting impossible				
to						
D						
E	ROM/RAM/switch test					
F	Self-loopback test					
Station number setting switch		The station number of the module is set for data communications using dedicated protocol.	-	△		
Transmission specification switch	SW01	Operation setting	Operation (independent operation/linked operation) of the two interfaces is set.	-	△	Set the switches in PLC parameters using GX Works2.*1
	SW02	Data bit setting	The data bit length of the data to be transmitted/received is set.	-	△	
	SW03	Parity bit enable/disable setting	The parity bit status of the data to be transmitted/received is set.	-	△	
	SW04	Even parity/odd parity setting	The type of parity bit added to the data to be transmitted/received is set.	-	△	
	SW05	Stop bit setting	The stop bit length of the data to be transmitted/received is set.	-	△	
	SW06	Sum check enable/disable setting	The sum check code status in data communications using dedicated protocol is set.	-	△	
	SW07	Write during RUN enable/disable setting	The enable/disable status of Write during RUN in data communications using dedicated protocol is set.	-	△	
	SW08	Setting change enable/disable	The enable/disable status of mode switching and E ² PROM write is set.	-	△	
	SW09 to SW12	Transmission speed setting	The transmission speed for data communications is set.	-	△	
	SW13 to SW15	-	(All switches are set to OFF.)	-	-	

Section 2.7

*1 Set the L series serial communication module switch settings in PLC parameters of GX Works2.

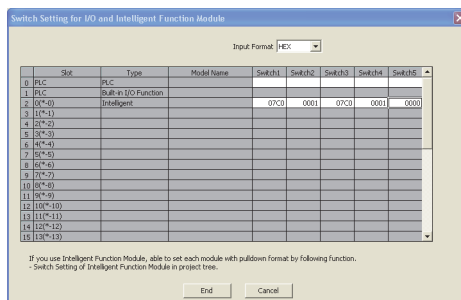

2.5 Program Comparison

2.5.1 I/O signal comparison

(1) Between AnS series and L series

I/O signal assignments are incompatible between AnS series and L series.

Create a new sequence program.

○ : Compatible, △ : Partial change required, × : Incompatible

Input signal	Signal name	Compatibility	Precautions for replacement
	AnS series		
	A1SJ71UC24-R2 A1SJ71UC24-R4		
Xn0	Send completed	△	In the L series, Xn0, Xn1, Xn7, and Xn8 are used as this signal.
Xn1	Received data read request	△	In the L series, Xn3, Xn4, XnA, and XnB are used as this signal.
Xn2	Global signal	△	In the L series, X(n+1)A and X(n+1)B are used as this signal.
Xn3	On-demand function operating	△	Transmission complete of on-demand data is confirmed by the complete device of the ONDEMAND instruction.
Xn4	Computer link module transmission sequence state	△	The status is confirmed in the buffer memory area, Transmission sequence state storage area (addresses: 597 (256 _H), 613 (265 _H)).
Xn5		△	
Xn6		△	
Xn7	Computer link module READY signal	△	In the L series, X(n+1)E is used as this signal.
Xn8	Use prohibited	△	In the L series, Xn8 is used as the transmission abnormal completion signal.
Xn9	Mode switching complete	△	In the L series, Xn6 is used as this signal.
XnA	Use prohibited	△	In the L series, XnA and XnB are used as signals for various applications (refer to (2)).
XnB	Use prohibited	△	
XnC	Use prohibited	○	
XnD	Watch dog timer error	△	In the L series, X(n+1)F is used as this signal.
XnE	Use prohibited	△	In the L series, XnE to X(n+1)F are used as signals for various applications (refer to (2)).
to	to	△	
X(n+1)F	Use prohibited	△	

Output signal	Signal name	Compatibility	Precautions for replacement
	AnS series		
	A1SJ71UC24-R2 A1SJ71UC24-R4		
Yn0	Use prohibited	△	In the L series, Yn0 to YnF are used as signals for various applications (refer to (2)).
to	to	△	
YnF	Use prohibited	△	
Y(n+1)0	Send request	△	In the L series, Yn0 and Yn7 are used as this signal.
Y(n+1)1	Received data read completed	△	In the L series, Yn1 and Yn8 are used as this signal.
Y(n+1)2	Use prohibited	△	In the L series, Y(n+1)2 to Y(n+1)8 are used as signals for various application (refer to (2)).
to	to	△	
Y(n+1)8	Use prohibited	△	
Y(n+1)9	Mode switching request	△	In the L series, Yn2 and Yn9 are used as this signal.
Y(n+1)A	Use prohibited	○	
Y(n+1)B	Use prohibited	○	
Y(n+1)C	Use prohibited	△	In the L series, Y(n+1)C is used as the system setting default request signal.
Y(n+1)D	Use prohibited	○	
Y(n+1)E	Use prohibited	○	
Y(n+1)F	Use prohibited	○	

(2) Between QnAS series and L series

○ : Compatible, △ : Partial change required, × : Incompatible

Device number	Signal name		Compatibility	Precautions for replacement		
	QnAS series					
	L series					
	A1S71QC24N1 A1S71QC24N1-R2	LJ71C24 LJ71C24-R2				
Xn0		Transmission ended normally		Transmission normal completion	○	
Xn1		Transmission ended abnormally		Transmission abnormal completion	○	
Xn2	CH1	Busy performing transmission processing	CH1	Transmission processing	○	
Xn3		Receive data read request		Reception data read request	○	
Xn4		Receive error detection		Reception abnormal detection	○	
Xn5	System area (use prohibited)			System area (use prohibited)	○	
Xn6	CH1 Mode switching (initial processing)			CH1 Mode switching	○	
Xn7		Transmission ended normally		Transmission normal completion	○	
Xn8		Transmission ended abnormally		Transmission abnormal completion	○	
Xn9	CH2	Busy performing transmission processing	CH2	Transmission processing	○	
XnA		Receive data read request		Reception data read request	○	
XnB		Receive error detected		Reception abnormal detection	○	
XnC	System area (use prohibited)			System area (use prohibited)	○	
XnD	CH2 Mode switching (initial processing)			CH2 Mode switching	○	
XnE	CH1 ERR. LED ON			CH1 ERR. occurrence	○	
XnF	CH2 ERR. LED ON			CH2 ERR. occurrence	○	
X(n+1)0	Initialization ended			Modem initialization completion	○	
X(n+1)1	Dialing			Dialing	○	
X(n+1)2	Connecting			Connection	○	
X(n+1)3	Initialization/connection ended abnormally			Initialization/connection abnormal completion	○	
X(n+1)4	Modem disconnection ended			Modem disconnection complete	○	
X(n+1)5	Notification ended normally			Notification ended normally	○	
X(n+1)6	Notification ended abnormally			Notification ended abnormally	○	
X(n+1)7	EEPROM read complete			Flash ROM read completion	○	
X(n+1)8	EEPROM write complete			Flash ROM write completion	○	
X(n+1)9	EEPROM system parameters write complete			Flash ROM system setting write completion	○	
X(n+1)A	CH1 Global signal			CH1 Global signal	○	
X(n+1)B	CH2 Global signal			CH1 Global signal	○	
X(n+1)C	System parameters default complete			System setting default completion	○	
X(n+1)D	System area (use prohibited)			System area (use prohibited)	○	
X(n+1)E	QC24N ready (access possible)			C24 ready	○	
X(n+1)F	Watchdog timer error			Watchdog timer error	○	

○ : Compatible, △ : Partial change required, × : Incompatible

Device number	Signal name				Compatibility	Precautions for replacement		
	QnAS series		L series					
	A1SJ71QC24N1 A1SJ71QC24N1-R2		LJ71C24 LJ71C24-R2					
Yn0	CH1	Send request		CH1	Transmission request		○	
Yn1		Receive data read complete			Reception data read completion		○	
Yn2		Remote switching request			Mode switching request		○	
Yn3	Use prohibited		Use prohibited		○			
to	to		to		○			
Yn6	Use prohibited		Use prohibited		○			
Yn7	CH2	Send request		CH2	Transmission request		○	
Yn8		Receive data read complete			Reception data read completion		○	
Yn9		Mode switching request			Mode switching request		○	
YnA	Use prohibited		Use prohibited		○			
to	to		to		○			
YnD	Use prohibited		Use prohibited		○			
YnE	CH1 ERR. LED OFF request		CH1 ERR. clear request		○			
YnF	CH2 ERR. LED OFF request		CH2 ERR. clear request		○			
Y(n+1)0	Initialization request		Modem initialization request (standby request)		○			
Y(n+1)1	Connection request		Connection request		○			
Y(n+1)2	Modem disconnection request		Modem disconnection request		○			
Y(n+1)3	Use prohibited		Use prohibited		○			
Y(n+1)4	Notification-issued request		Notification issued request		○			
Y(n+1)5	Use prohibited		Use prohibited		○			
Y(n+1)6	Use prohibited		Use prohibited		○			
Y(n+1)7	EEPROM read request		Flash ROM read request		○			
Y(n+1)8	EEPROM write request		Flash ROM write request		○			
Y(n+1)9	EEPROM system parameters write request		Flash ROM system setting write request		○			
Y(n+1)A	Use prohibited		Use prohibited		○			
Y(n+1)B	Use prohibited		Use prohibited		○			
Y(n+1)C	System parameters default request		System setting default request		○			
Y(n+1)D	Use prohibited		Use prohibited		○			
Y(n+1)E	Use prohibited		Use prohibited		○			
Y(n+1)F	Use prohibited		Use prohibited		○			

2.5.2 Buffer memory address comparison

(1) Between AnS series and L series

Buffer memory address assignments are incompatible between AnS series and L series.
Create a new sequence program.

The following table lists the default address assignments for the areas used for initial setting and data communications.

○ : Compatible, △ : Partial change required, × : Incompatible

Address		AnS series Name	Compatibility	Precautions for replacement
Hexadecimal	Decimal	A1SJ71UC24-R2 A1SJ71UC24-R4		
0 _H	0	No-protocol send data length storage area	△	In the L series, this area is assigned to the addresses 400 _H , 800 _H (1024, 2048).
1 _H to 7F _H	1 to 127	Send data storage area	△	In the L series, this area is assigned to the addresses starting from 401 _H , 801 _H (1025, 2049).
80 _H	128	No-protocol received data length storage area	△	In the L series, this area is assigned to the addresses 600 _H , A00 _H (1536, 2560).
81 _H to FF _H	129 to 255	Received data storage area	△	In the L series, this area is assigned to the addresses starting from 601 _H , A01 _H (1537, 2561).
100 _H to to	256 to to	Area to specify completed code in no-protocol mode	△	In the L series, this area is assigned to the addresses A5 _H , 145 _H (165, 325).
103 _H	259	Area to specify word or byte units in no-protocol mode	△	In the L series, this area is assigned to the addresses 96 _H , 136 _H (150, 310). ^{*1}
104 _H	260	Area to specify head address of send buffer memory for no-protocol mode	△	In the L series, this area is assigned to the addresses A2 _H , 142 _H (162, 322). ^{*1}
105 _H	261	Area to specify send buffer size for no-protocol mode	△	In the L series, this area is assigned to the addresses A3 _H , 143 _H (163, 323). ^{*1}
106 _H	262	Area to specify head address of receive buffer memory for no-protocol mode	△	In the L series, this area is assigned to the addresses A6 _H , 146 _H (166, 326). ^{*1}
107 _H	263	Area to specify receive buffer size for no-protocol mode	△	In the L series, this area is assigned to the addresses A7 _H , 147 _H (167, 327). ^{*1}
108 _H	264	Area to specify receive completed data length in no-protocol mode	△	In the L series, this area is assigned to the addresses A4 _H , 144 _H (164, 324). ^{*1}
109 _H	265	Area to specify head address of on-demand buffer memory	△	In the L series, this area is assigned to the addresses A0 _H , 140 _H (160, 320). ^{*1}
10A _H	266	Area to specify on-demand data length	△	In the L series, this area is assigned to the addresses A1 _H , 141 _H (161, 321). ^{*1}
10B _H to DFF _H	267 to 3583	Area to specify RS-232C CD terminal check	△	In the L series, this area is assigned to the addresses 97 _H , 137 _H (151, 311). ^{*1} In the L series, 10C _H (152) and subsequent addresses are used for various applications.

*1 Configure initial settings using the utility package (GX Configurator-SC).
If GX Works2 is used, configure initial settings under intelligent function module settings.

(2) QnAS series

The following table lists the default address assignments for the areas used for initial setting and data communications.

○ : Compatible, △ : Partial change required, × : Incompatible

Address		Name		Compatibility	Precautions for replacement
Hexadecimal	Decimal	QnAS series A1SJ71QC24N1 A1SJ71QC24N1-R2	L series LJ71C24 LJ71C24-R2		
0 _H	0	System setting area	LED and communication error clear	-	
		CH1 LED OFF, communication error clear request area	CH1 LED OFF, communication error clear request	○	
to	to	to	to	○	
2E _H	46	Areas for modem functions (For initial setting)	Areas for modem functions-1 (For initial setting)	○	
to	to				
38 _H	56				
39 _H	57	System area (Use prohibited)	System area (Use prohibited)	○	
to	to	to	to	○	
8F _H	143	System area (Use prohibited)	System area (Use prohibited)	○	
90 _H , 130 _H	144, 304	Areas for mode switching	Areas for mode switching	○	
91 _H , 131 _H	145, 305				
92 _H , 132 _H	146, 306	System area (Use prohibited)	RS and DTR signal status designation	△	Use the default value.
93 _H , 133 _H	147, 307	DTR/DSR, DC control designation	DTR/DSR, DC control designation	○	
94 _H , 134 _H	148, 308	DC1/DC3 code designation	DC1/DC3 code designation	○	
95 _H , 135 _H	149, 309	DC2/DC4 code designation	DC2/DC4 code designation	○	
96 _H , 136 _H	150, 310	Word/byte designation	Word/byte units designation	○	
97 _H , 137 _H	151, 311	RS-232 CD terminal check designation	CD terminal check designation (for RS-232)	○	
to	to	to	to	○	
A0 _H , 140 _H	160, 320	On-demand, buffer memory head address designation	On-demand, buffer memory head address designation	○	
A1 _H , 141 _H	161, 321	On-demand, data length designation	On-demand, data length designation	○	
A2 _H , 142 _H	162, 322	Send buffer memory head address designation	Transmission buffer memory head address designation	○	
A3 _H , 143 _H	163, 323	Send buffer memory length designation	Transmission buffer memory length designation	○	
A4 _H , 144 _H	164, 324	Received data count designation	Received data count designation	○	
A5 _H , 145 _H	165, 325	Receive complete code designation	Receive complete code designation	○	
A6 _H , 146 _H	166, 326	Receive buffer memory head address designation	Receive buffer memory head address designation	○	
A7 _H , 147 _H	167, 327	Receive buffer memory length designation	Receive buffer memory length designation	○	
to	to	to	to	○	
200 _H	512	System information area	System information area	○	
to	to				
220 _H	544				
221 _H	545	Areas for modem functions	Areas for modem functions	○	
to	to				
23D _H	573				
23E _H	574	System information area	System area (Use prohibited)	-	
to	to				
24E _H	590	System area (Use prohibited)		○	
24F _H	591		Station No. setting check	○	
to	to	to	to	○	
3FF _H	1023	System area (Use prohibited)	System area (Use prohibited)	○	

○: Compatible, △: Partial change required, ×: Incompatible

Address		Name		Compatibility	Precautions for replacement
Hexadecimal	Decimal	QnAS series	L series		
		A1SJ71QC24N1 A1SJ71QC24N1-R2	LJ71C24 LJ71C24-R2		
400 _H	1024	CH1 Send/receive buffer memory	CH1 Transmission/receive area	-	
401 _H	1025	Send data count designation	Transmission data count designation	○	
to	to	Send data designation	Transmission data designation	○	
5FF _H	1535				
600 _H	1536	Receive data count designation	Receive data count designation	○	
601 _H	1537				
to	to	Receive data storage	Receive data storage	○	
7FF _H	2047				
800 _H	2048	CH2 send/receive buffer memory	CH2 Transmission/receive area	-	
		Send data count designation	Transmission data count designation	○	
801 _H	2049				
to	to	Send data designation	Transmission data designation	○	
9FF _H	2559				
A00 _H	2560	Receive data count designation	Receive data count designation	○	
A01 _H	2561				
to	to	Receive data storage	Receive data storage	○	
BFF _H	3071				
C00 _H	3072				
to	to	User area	User setting area	○	
1AFF _H	6911				
1B00 _H	6912				
to	to	User frame registration	User registration data	○	
1FF6 _H	8182				
1FF7 _H	8183				
to	to	System area(Use prohibited)	System area (Use prohibited)	○	
1FFF _H	8191				
2000 _H	8192		Flash ROM write allow/prohibit designation		
2001 _H	8193				
to	to		(Areas for new functions)	△	Sequence programs need to be added depending on the functions used.
7FFF _H	32767				

2.6 Reuse of Existing Programs

2.6.1 Reuse of AnS series programs

Data communications between the CPU module and external devices and between CPU modules that have been performed by the AnS series computer link modules can also be performed using the L series serial communication modules.

The following summarizes how to utilize AnS series computer link module programs for the L series serial communication modules after module replacement.

Item	Device	Precautions	Remarks
Initial setting	CPU module	[Initial settings using the utility package] Make initial settings using the utility package (GX Configurator-SC). [Deleting the initial setting program] Delete the initial setting program. [Setting the sum check code of the bidirectional protocol] To add sum check codes to the messages in bidirectional protocol communications, configure switch settings in PLC parameters using GX Works2.	Refer to the MELSEC-L Serial Communication Module User's Manual (Basic).
Communication using dedicated protocol (MC protocol communication)	CPU module	[Access to another station] When accessing other station's CPU module via MELSECNET/H, set "Valid module during other station access" in network parameters using GX Works2. [Data transmission by the on-demand function] Change to a sequence program that uses the dedicated instruction (ONDEMAND).	<ul style="list-style-type: none"> Refer to the GX Works2 Version 1 Operating Manual (Common). Refer to the MELSEC-L Serial Communication Module User's Manual (Basic). Refer to the MELSEC-Q/L MELSEC Communication Protocol Reference Manual.
	Communication target device	[Accessing the CPU module] The applicable commands, accessible device ranges, and access to another station are restricted. ^{**12} [Access to another station] Another station cannot be accessed via the data link system (MELSECNET(II), MELSECNET/B).	
Nonprocedural communication (Nonprocedural protocol communication)	CPU module	[Transmission/reception of data] Change to a sequence program that uses the dedicated instructions (INPUT, OUTPUT).	Refer to the MELSEC-L Serial Communication Module User's Manual (Basic).
	Communication target device	[Transmission of data] When receiving data by the receive end code on the CPU module side, transmit the end code data (default: CR+LF (codes: 0D _H , 0A _H)) at the end of the data to be transmitted to the CPU module. ^{**3}	
Bidirectional communication (Bidirectional protocol communication)	CPU module	[Transmission/reception of data] Change to a sequence program that uses the dedicated instructions (BIDIN, BIDOUT).	
Transmission using printer function	CPU module	[Printing messages on a printer] When messages ^{**4} were being printed on a printer, create a transmission program using user frames of the L series serial communication module. ^{**5} Delete programs that use the regular printer function.	Refer to the MELSEC-Q/L Serial Communication Module User's Manual (Application).
Others	CPU module	[Assignment of I/O signals] There is no compatibility in the I/O signal (X/Y) assignments between the AnS and L series. Check the I/O signals (X/Y) in use, and correct the program.	Refer to the MELSEC-L Serial Communication Module User's Manual (Basic).
	CPU module and communication target device	[Assignment of buffer memory areas] There is no compatibility in the buffer memory area assignments between the AnS and L series. Check the target buffer memory areas of the data to be read/written and their addresses, and correct the program.	

- *1 External devices can access only the device memory in the CPU module.
 The accessible device range is the same as that of the AnS series CPU module.
 The following devices cannot be accessed from external devices:
 - Devices newly added to the LCPU
 - Latch relay (L) and step relay (S)
 - * In the LCPU, the latch relay (L) and step relay (S) are devices separate from the internal relay (M). However, external devices access the internal relay (M) when either of the latch relay (L) or step relay (S) is specified.
 - File register (R)
 To access memories other than device memory, use new commands for L series serial communication modules.
 (Create a new program.)
- *2 The following devices shall be accessed for the special relay (M9000 or later) and special register (D9000 or later):
 - When D9000 to D9255 are specified: SD1000 to SD1255
 - When D9000 to D9255 are specified: SM1000 to SM1255
- *3 Registering a receive end code to the L series serial communication module enables data transmission from external devices in the same way that the AnS series computer link module did.
- *4 User frames of the L series serial communication modules are equivalent to messages handled by the AnS series computer link modules.
- *5 Messages (user frames) can be registered using the utility package (GX Configurator-SC).
 Messages are transmitted by using the dedicated instruction (PRR). If GX Works2 is used, messages can be transmitted using its intelligent function module setting.

2.6.2 Reuse of QnAS series programs

Data communications between the CPU module and external devices and between CPU modules that have been performed by the QnAS series serial communication modules can also be performed using the L series serial communication modules.

The following summarizes how to utilize QnAS series serial communication module programs for the L series serial communication modules after module replacement.

Item	Device	Precautions	Remarks
Communication by link dedicated instruction	CPU module	[Communication by link dedicated instruction] There is no function that sends/receives data to/from the CPU module on another station (multidrop connection) using link dedicated instructions. The communication method needs to be changed (e.g. communication over CC-Link network). Delete the data communication program using the link dedicated instruction.	
Others	Communication target device	[Data communications via RS-422/485 interface] The precautions for data communications via RS-422/485 interface are the same as those for the QnAS series serial communication modules. Check operation of the RS-422/485 interface of the CPU module, and adjust the timing by inserting a waiting time, as needed.	Refer to the MELSEC-L Serial Communication Module User's Manual (Basic).

2.7 Other Precautions

This section describes other precautions for module replacement.

(1) Processing time

The processing time for data communications differs between the AnS/QnAS series and L series modules.

For this reason, some data communications timing may be also different. Adjust the timing by inserting a waiting time, as needed.

For details on processing time, refer to the manual for the module used.

(2) Switch settings

To use L series serial communication modules, set the operation mode, station number, and transmission specifications in the following parameter setting window using GX Works2:

- "Switch setting for intelligent function module" window

The L series serial communication modules do not have switches for setting the mode, station number, and transmission specifications.

(3) Data communications via RS-422/485 interface

The precautions for data communications via RS-422/485 interface are the same as those for the QnAS series serial communication modules.

If external devices may receive the wrong data, attach a pullup/pulldown transistor to the external devices.

2.8 Program Examples

This section provides modification examples of the nonprocedural communications program for the AnS series computer link module to the one for L series serial communication module. Program modification is required when replacing AnS series programmable controller systems with L series programmable controller systems.

When applying the program examples introduced in this section to the actual system, ensure applicability and confirm that it will not cause system control problems.

(1) Program example of AnS series computer link module

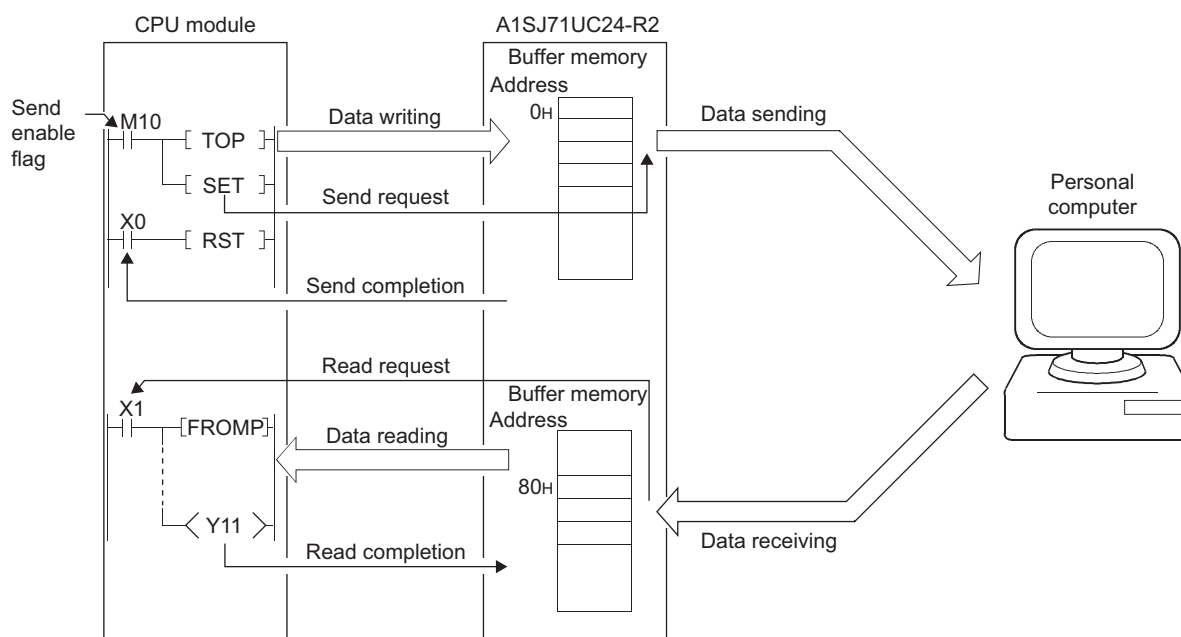

(When using FROM/TO instruction)

(a) When application instructions (FROM/TO) are used

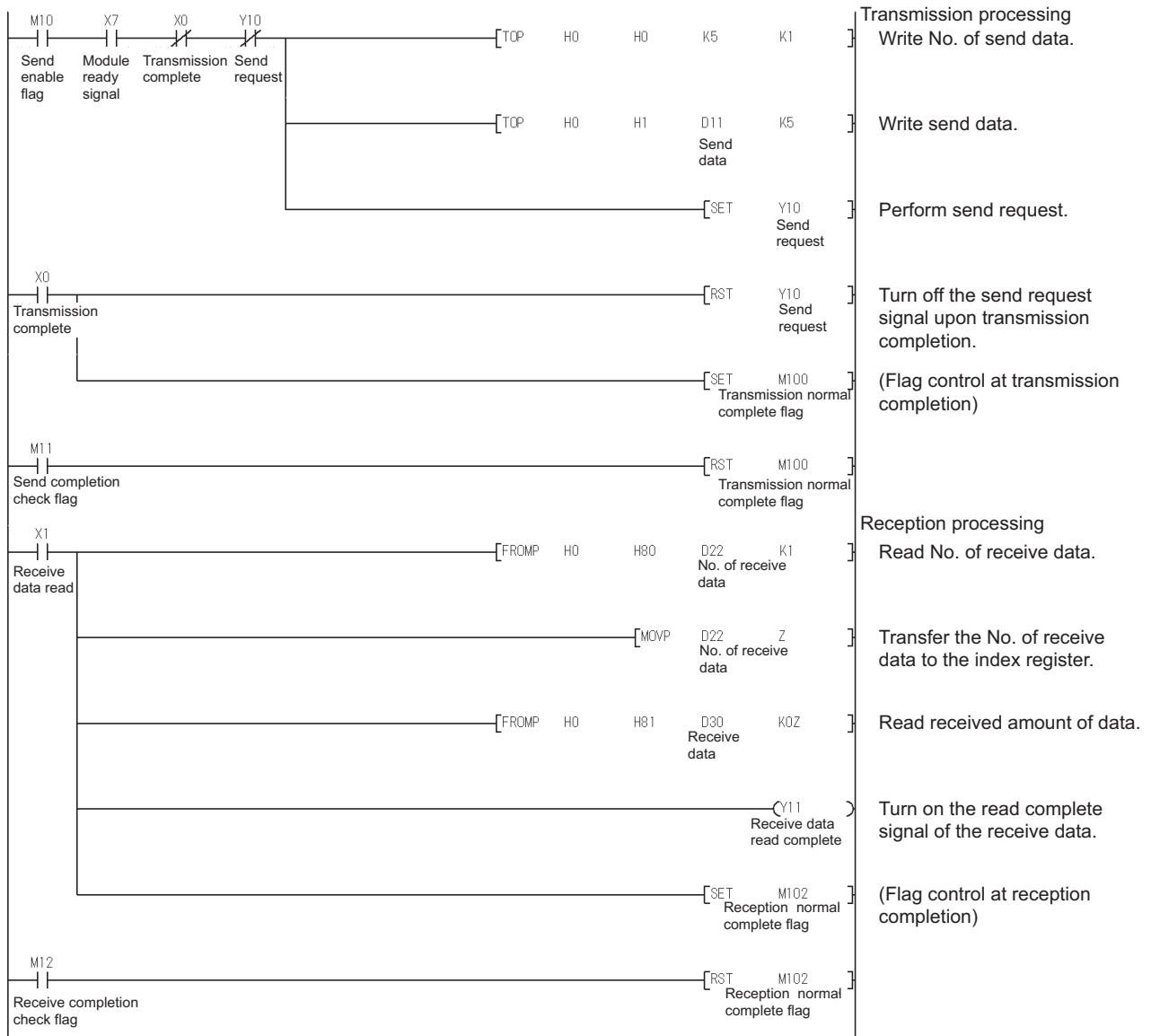

(b) When dedicated instructions (PRN/INPUT) are used

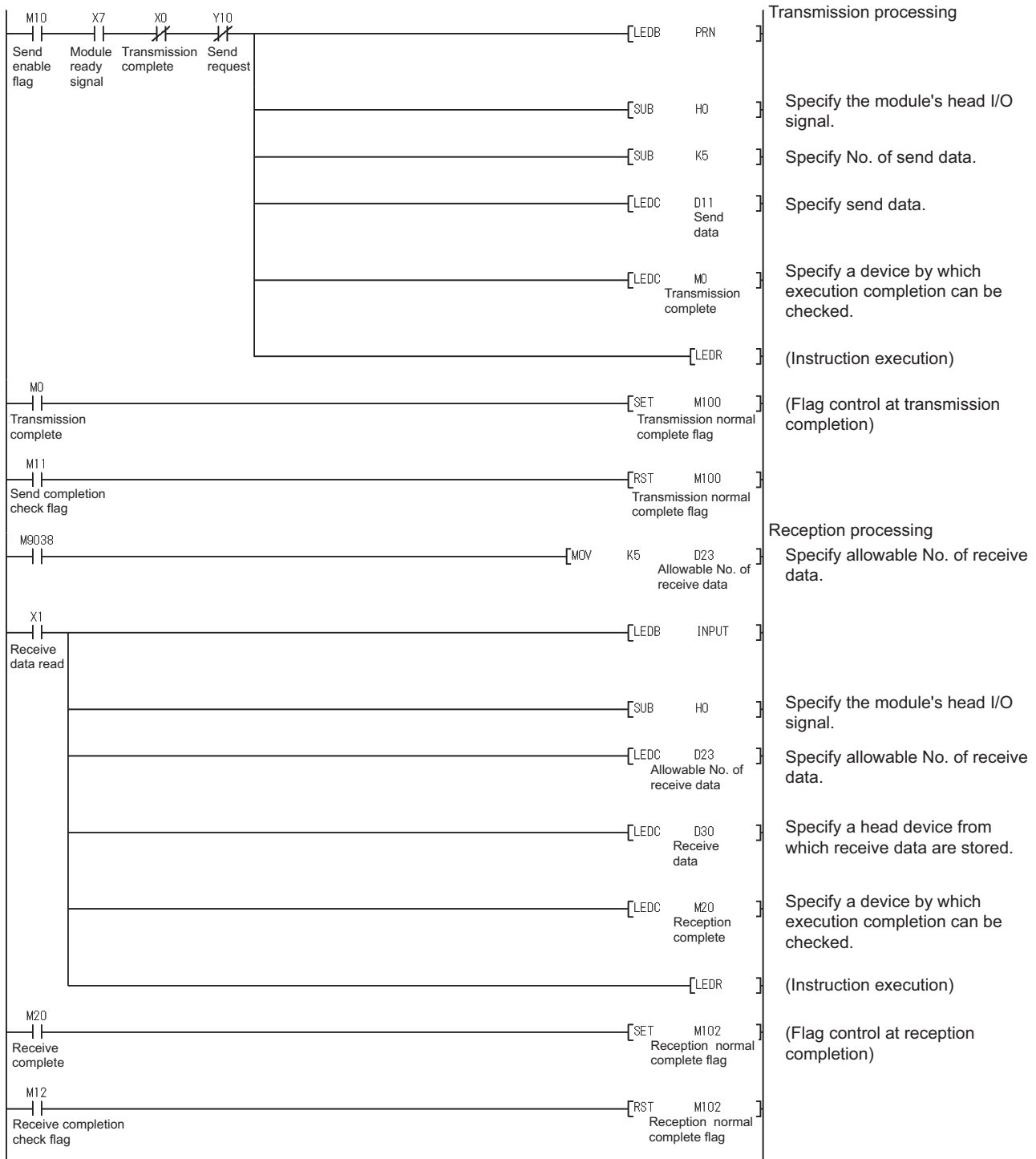

(2) Program example of L series serial communication module

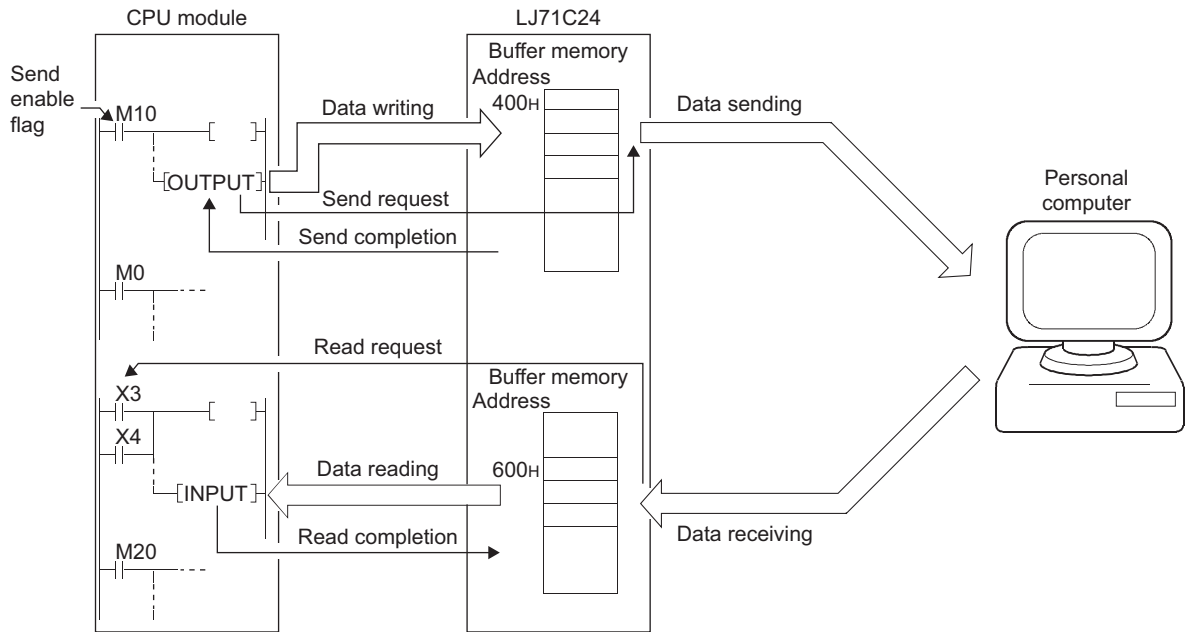

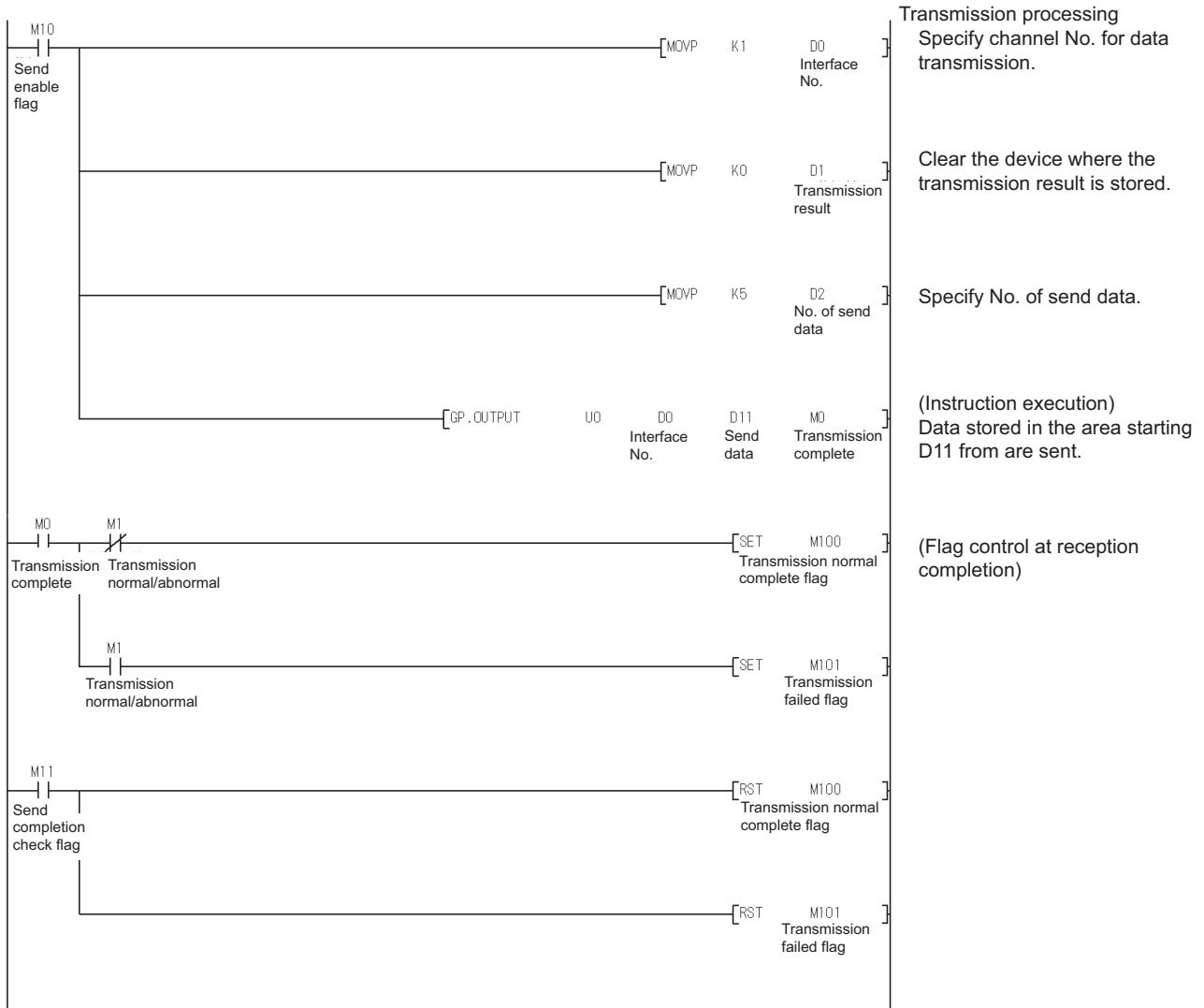

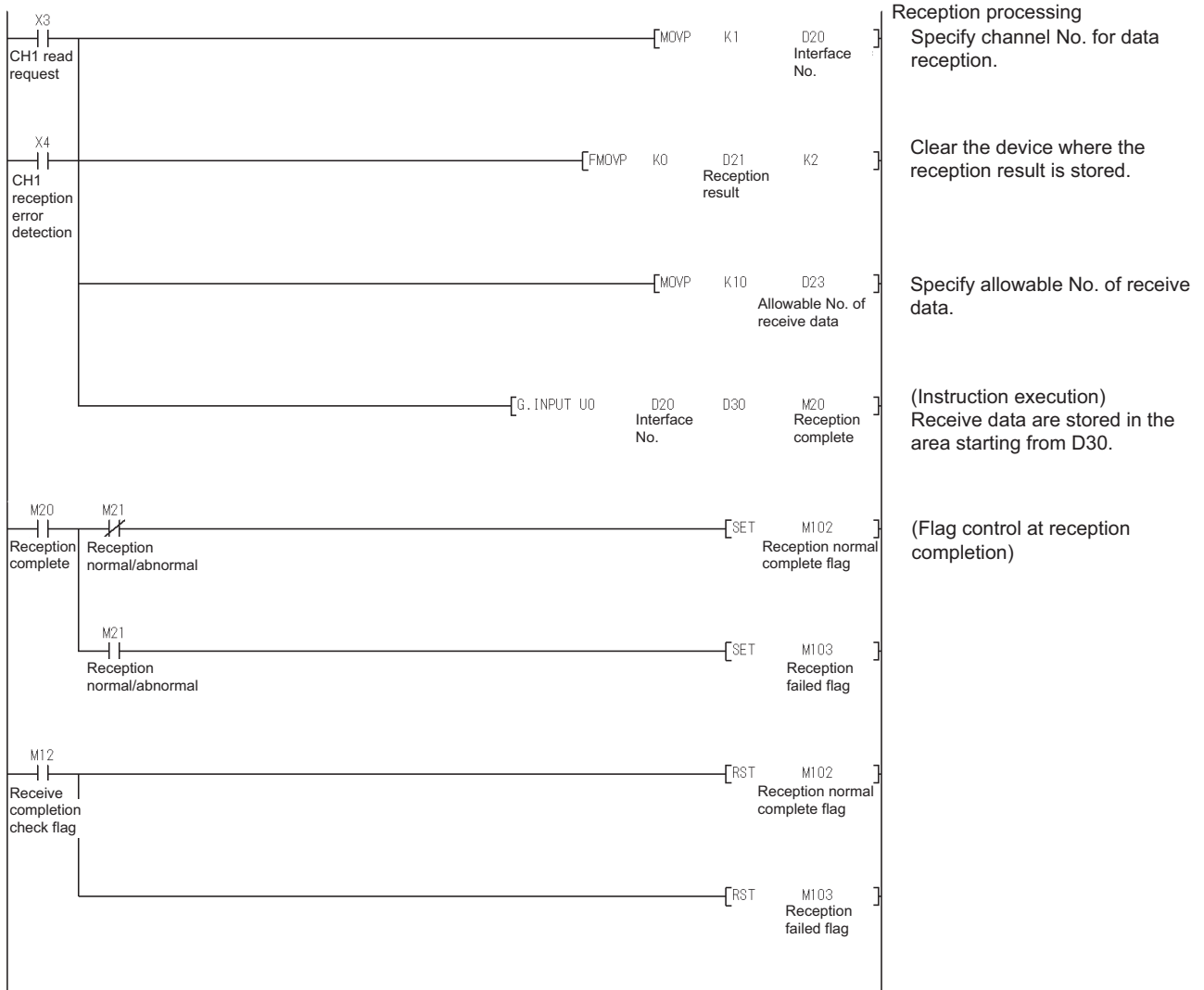

3 ETHERNET INTERFACE MODULE REPLACEMENT

3.1 List of Ethernet Interface Modules to be Replaced

(1) Transition from AnS series to L series

AnS series	Alternative model
A1SJ71E71N3-T	LJ71E71-100
A1SJ71E71N-B5	
A1SJ71E71N-B2	

(2) Transition from QnAS series to L series

QnAS series	Alternative model
A1SJ71QE71N3-T	LJ71E71-100
A1SJ71QE71N-B5	
A1SJ71QE71N-B2	

3.2 Performance Specifications Comparison

3.2.1 Module performance comparison

(1) Comparison between AnS series and L series

(a) Comparison between A1SJ71E71N3-T (10BASE-T)

○ : Compatible, △ : Partial change required, × : Incompatible

Item	Specifications		Compatibility	Precautions for replacement	
	AnS series	L series			
	A1SJ71E71N3-T	LJ71E71-100			
Transmission specifications	Transmission speed	10Mbps	100Mbps/10Mbps	○	
	Interface	RJ45	RJ45 (AUTO MDI/MDI-X)	△	
	Communication mode	Half-duplex	Full duplex/Half-duplex	○	
	Transmission method	Base band		○	
	Maximum segment length	100m*1		○	
	Maximum number of nodes/connection	Cascade connection: Up to 4 *2		○	Up to two modules can be connected in a cascade connection when using at 100 Mbps. *2
Transfer data storage memory	Number of allowable simultaneously open connections	8 connections	16 connections	○	
	Fixed buffer	1k word × 8	1k word × 16	△	Change the sequence program as buffer memory assignments differ. (Refer to Section 3.6.2.)
	Random access buffer	3k words × 2	6k words × 1	△	
No. of occupied I/O points	32 points/slot (I/O assignment: special 32 points)	32 points (I/O assignment: intelli 32 points)	○		

*1 Length between hub and node

*2 This is the number of nodes that can be connected when a repeater hub is used. For the number of nodes that can be connected when a switching hub is used, contact the manufacturer of the switching hub used.

(b) Comparison between A1SJ71E71N-B5 (10BASE5)

○ : Compatible, △ : Partial change required, × : Incompatible

Item	Specifications		Compatibility	Precautions for replacement
	AnS series	L series		
	A1SJ71E71N-B5	LJ71E71-100		
Transmission specifications	Transmission speed	10Mbps	Consider converting 10BASE5 to 10BASE-T.	×
	Communication mode	Half-duplex		×
	Transmission method	Base band		×
	Max. distance between nodes	2500m		×
	Maximum segment length	500m		×
	Maximum number of nodes/connection	100/segment		×
	Minimum node interval	2.5m		×
Transfer data storage memory	Number of allowable simultaneously open connections	8 connections	16 connections	○
	Fixed buffer	1k word × 8	1k word × 16	△
	Random access buffer	3k words × 2	6k words × 1	△
No. of occupied I/O points		32 points/slot (I/O assignment: special 32 points)	32 points (I/O assignment: intelli 32 points)	○
12VDC external power supply capacity (Transceiver)		Use a transceiver and AUI cables that satisfy specifications.	Consider converting 10BASE5 to 10BASE-T.	×

(c) Comparison between A1SJ71E71N-B2 (10BASE2)

○ : Compatible, △ : Partial change required, × : Incompatible

Item	Specifications		Compatibility	Precautions for replacement
	AnS series	L series		
	A1SJ71E71N-B2	LJ71E71-100		
Transmission specifications	Transmission speed	10Mbps	Consider converting 10BASE2 to 10BASE-T.	×
	Communication mode	Half-duplex		×
	Transmission method	Base band		×
	Max. distance between nodes	925m		×
	Maximum segment length	185m		×
	Maximum number of nodes/connection	30/segment		×
	Minimum node interval	0.5m		×
Transfer data storage memory	Number of allowable simultaneously open connections	8 connections	16 connections	○
	Fixed buffer	1k word × 8	1k word × 16	△
	Random access buffer	3k words × 2	6k words × 1	△
No. of occupied I/O points		32 points/slot (I/O assignment: special 32 points)	32 points (I/O assignment: intelli 32 points)	○

(2) Comparison between QnAS series and L series

(a) Comparison between A1SJ71QE71N3-T (10BASE-T)

○ : Compatible, △ : Partial change required, × : Incompatible

Item	Specifications		Compatibility	Precautions for replacement	
	QnAS series	L series			
	A1SJ71QE71N3-T	LJ71E71-100			
Transmission specification	Transmission speed	10Mbps	100Mbps/10Mbps	○	
	Interface	RJ45	RJ45 (AUTO MDI/MDI-X)	△	
	Communication mode	Half-duplex	Full duplex/Half-duplex	○	
	Transmission method	Base band		○	
	Maximum segment length	100m ^{*1}		○	
	Maximum number of nodes/connection	Cascade connection: Up to 4 ^{*2}		○	Up to two modules can be connected in a cascade connection when using at 100 Mbps. ^{*2}
Transfer data storage memory	Number of allowable simultaneously open connections	8 connections	16 connections	○	
	Fixed buffer	1k word × 8	1k word × 16	○	
	Random access buffer	6k words × 1		○	
No. of E ² PROM writes	Max. 100,000 times on same area in E ² PROM	-		△	No E ² PROM (Refer to Section 3.8.)
No. of occupied I/O points	32 points/slot (I/O assignment: special 32 points)	32 points (I/O assignment: intelli 32 points)		○	

*1 Length between hub and node

*2 This is the number of nodes that can be connected when a repeater hub is used. For the number of nodes that can be connected when a switching hub is used, contact the manufacturer of the switching hub used.

(b) Comparison between A1SJ71QE71N-B5 (10BASE5)

○ : Compatible, △ : Partial change required, × : Incompatible

Item	Specifications		Compatibility	Precautions for replacement	
	QnAS series	L series			
	A1SJ71QE71N-B5	LJ71E71-100			
Transmission specifications	Transmission speed	10Mbps	Consider converting 10BASE5 to 10BASE-T.	×	
	Communication mode	Half-duplex		×	
	Transmission method	Base band		×	
	Max. distance between nodes	2500m		×	
	Maximum segment length	500m		×	
	Maximum number of nodes/connection	100/segment		×	
	Minimum node interval	2.5m		×	
Transfer data storage memory	Number of allowable simultaneously open connections	8 connections	16 connections	○	
	Fixed buffer	1k word × 8	1k word × 16	○	
	Random access buffer	6k words × 1		○	
No. of E ² PROM writes	Max. 100,000 times on same area in E ² PROM	-		△	No E ² PROM (Refer to Section 3.8.)
No. of occupied I/O points	32 points/slot (I/O assignment: special 32 points)	32 points (I/O assignment: intelli 32 points)		○	
12VDC external power supply capacity (Transceiver)	Use a transceiver and AUI cables that satisfy specifications.	Consider converting 10BASE5 to 10BASE-T.		○	

(c) Comparison between A1SJ71QE71N-B2 (10BASE2)

○ : Compatible, △ : Partial change required, × : Incompatible

Item	Specifications		Compatibility	Precautions for replacement
	QnAS series	L series		
	A1SJ71QE71N-B2	LJ71E71-100		
Transmission specifications	Transmission speed	10Mbps	Consider converting 10BASE2 to 10BASE-T.	×
	Communication mode	Half-duplex		×
	Transmission method	Base band		×
	Max. distance between nodes	925m		×
	Maximum segment length	185m		×
	Maximum number of nodes/connection	30/segment		×
	Minimum node interval	0.5m		×
Transfer data storage memory	Number of allowable simultaneously open connections	8 connections	16 connections	○
	Fixed buffer	1k word × 8	1k word × 16	○
	Random access buffer	6k words × 1		○
No. of E ² PROM writes	Max. 100,000 times on same area in E ² PROM	–		△ No E ² PROM (Refer to Section 3.8.)
No. of occupied I/O points	32 points/slot (I/O assignment: special 32 points)	32 points (I/O assignment: intelli 32 points)		○

3.2.2 Cable specifications comparison

The L series does not support 10BASE5 and 10BASE2 of the Ethernet standards. Consider converting 10BASE5 and 10BASE2 to 10BASE-T using a media converter.

If 10BASE-T has been used in the AnS/QnAS series system, the connected devices such as hubs^{*1} or cables can be used without modification.

For details on the connection devices, refer to the MELSEC-L Ethernet Interface Module User's Manual (Basic).

*1 When connecting a hub that does not have the auto-negotiation function
On a connection with a hub that does not have the auto-negotiation function, set the hub side to the half-duplex communication mode.

3.3 Functional Comparison

(1) Comparison between AnS series and L series

○ : Compatible, △ : Partial change required, × : Incompatible

Item	Description		Compatibility	Precautions for replacement
	AnS series	L series		
	A1SJ71E71N3-T A1SJ71E71N-B5 A1SJ71E71N-B2	LJ71E71-100		
Initial processing	The state in which data communications with an external device is possible is set.		△	Set in the GX Works2 network parameters. *1 (Delete the sequence program of the section corresponding to the function.) (Refer to Section 3.9.)
Open processing	The communications line for performing data communications with external devices is connected.		△	Change to a sequence program that uses the dedicated instructions (OPEN, CLOSE). *5 (Refer to Section 3.9.)
Communications using fixed buffer (procedural, nonprocedural)	The fixed buffer on the Ethernet interface module is used to send/receive the desired data between the programmable controller CPU and external devices.		△	Change to a sequence program that uses the dedicated instructions (BUFSND, BUFRCV). (Refer to Section 3.9.)
Communications using random access buffer	Data is read/written to the random access buffer of the Ethernet interface module from multiple external devices.		△	Change the sequence program as buffer memory assignments differ. (Refer to Section 3.6.2.)
Read/write communications of programmable controller CPU internal data	Programmable controller CPU data is read/written to and from external devices.		△	Some of the commands and device ranges are restricted. (Refer to Section 3.7.)
Broadcast communication	Data is sent/received to all external devices on the same Ethernet network as the Ethernet interface module by UDP/IP-based data communications. (broadcast)		○	
Communications while the programmable controller CPU is stopped	Data communications can be continued when the programmable controller CPU enters a stop state. (during passive open processing)		△	Set in the GX Works2 network parameters. *2 (Delete the sequence program of the section corresponding to the function.)
Router relay function	Data communications is performed via a router and a gateway.		△	Set in the GX Works2 network parameters. *3 (Delete the sequence program of the section corresponding to the function.)
Existence check of external device	Whether or not the external device is operating normally after the connection is established (in open processing) is checked.		△	Change to a sequence program that uses the dedicated instructions (OPEN). *5
Communications using pairing open	The connection is opened with connection for reception and connection for transmission as a single pair. (for fixed buffer communications)		△	Change to a sequence program that uses the dedicated instructions (OPEN). *4*5
Unit of timer set values for data communications	Set the unit (500ms/2s) of timer values	Fixed to 500ms	△	Set in the GX Works2 network parameters. (Delete the sequence program of the section corresponding to the function.) The unit of timer set values is 500ms.

***1 Initial processing**

The L series performs initial processing by setting the following items in the GX Works2 network parameters.

- Settings from "Network Type" to "Mode"
- "Operation Setting"
- "Initial Setting"

There is no need for a sequence program for initial processing/end processing.

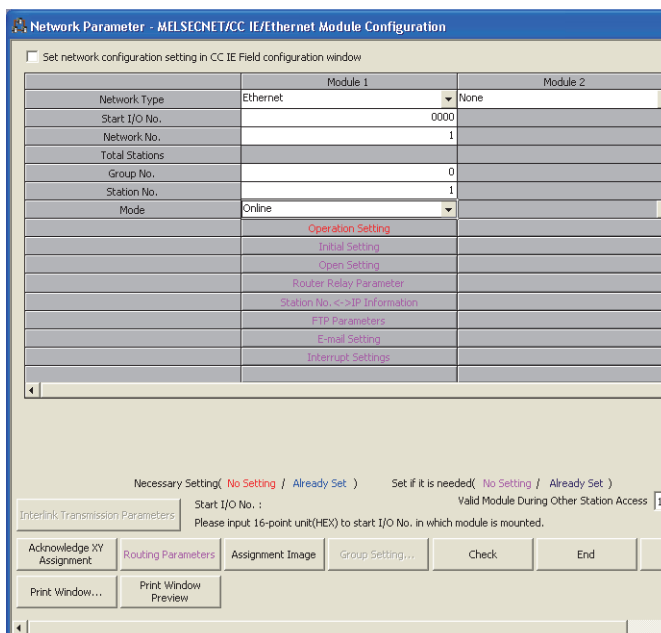

***2 Communications while the programmable controller CPU is stopped**

By setting "Operation Setting" - "Initial Timing" to "Always wait for OPEN", the L series can perform communications while the programmable controller CPU is stopped.

For connections for which passive open and communications during a stop are set to enabled, it is not necessary to use a sequence program for communications during a stop/open processing/close processing.

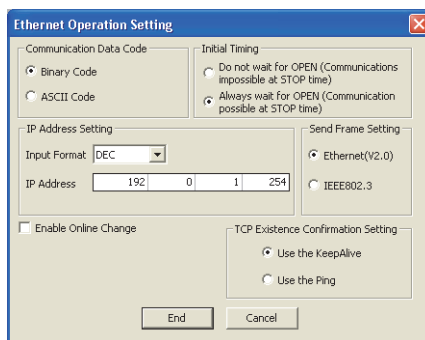

***3 Router relay function**

The L series sets the router relay function at "Network Parameter" - "Router Relay Parameter" on GX Works2.

There is no need for a sequence program for the router relay function.

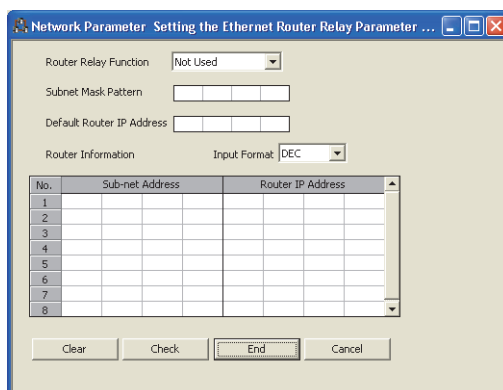

- *4 Communications using pairing open
 On the L series, the pairing open setting of connection No.8 and 16 is not possible.
 (The AnS series supported the pairing open setting of connection No. 8 for receiving and connection No. 1 for sending.)
 When the pairing open setting of connection No.8 has been made, change the sequence program.
 On the L series, the pairing open settings of connection No.1 to 7, and 9 to 15 are possible.
- *5 Open processing
 When "Operation Setting" - "Initial Timing" in GX Works2 is set to "Always wait for OPEN", the sequence program using dedicated instruction (OPEN/CLOSE) is not required.

(2) Comparison between QnAS series and L series

○ : Compatible, △ : Partial change required, × : Incompatible

Item		Description		Compatibility	Precautions for replacement
		QnAS series	L series		
		A1SJ71QE71N3-T A1SJ71QE71N-B5 A1SJ71QE71N-B2	LJ71E71-100		
Initial processing	Sequence program	The state in which data communications with an external device is possible is set.		△	Some communications are restricted. *1
	GX Works2 network parameters			○	
Open processing		The communications line for performing data communications with external devices is connected.		○	
Communications using fixed buffer (procedural, nonprocedural)		The fixed buffer on the Ethernet interface module is used to send/receive the desired data between the programmable controller CPU and external devices.		○	
Communications using random access buffer		Data is read/written to the random access buffer of the Ethernet interface module from multiple external devices.		○	
Read/write communications of programmable controller CPU internal data		Programmable controller CPU data is read/written to and from external devices.		△	Some of the commands and device ranges are restricted. (Refer to Section 3.7.)
Communications using data link instructions		Use data link instructions to read/write programmable controller CPU data of other stations via Ethernet.		○	
File transfer (FTP server functions)		Use FTP commands to read/write individual files from external devices.		△	The default log-in name and password have been changed from "AJ71QE71" to "LJ71E71", so set the log-in name again.
Broadcast communication		Data is sent/received to all external devices on the same Ethernet network as the Ethernet interface module by UDP/IP-based data communications. (broadcast)		○	
Communications while the programmable controller CPU is stopped		Data communications can be continued when the programmable controller CPU enters a stop state. (during passive open processing)		△	Delete the sequence program of the section corresponding to the function, and set in the GX Works2 network parameters. *2
MELSECNET/H, MELSECNET/10 relay exchange		On a network system comprising a mixture of Ethernet and MELSECNET/H or MELSECNET/10, or a network system that relays through multiple Ethernets, data communications is performed via these multiple networks.		△	Some communications are restricted. *3
Router relay function		Data communications is performed via a router and a gateway.		○	
Existence check of external device		Whether or not the external device is operating normally after the connection is established (in open processing) is checked.		○	
Communications using pairing open		The connection is opened with connection for reception and connection for transmission as a single pair. (for fixed buffer communications)		△	Some communications are restricted. *4
Parameter registration to E ² PROM		Saves parameters to E ² PROM.	–	△	No E ² PROM (Refer to Section 3.8.)

- *1 Initial processing using a sequence program
 - All of the items such as data code setting that were set on the QnA series exchange condition setting switch operate in an OFF state.
To change the communication conditions, add the sequence program for re-initial processing.
 - As the network number and station number cannot be set, the Ethernet interface module cannot be connected with MELSOFT products such as GX Works2.
To perform the above, perform initial processing by GX Works2 network parameters.

- *2 Communications while the programmable controller CPU is stopped
By setting "Operation Setting" - "Initial Timing" to "Always wait for OPEN", the L series can perform communications while the programmable controller CPU is stopped.
For connections for which passive open and communications during a stop are set to enabled, it is not necessary to use a sequence program for communications during a stop/open processing/close processing.

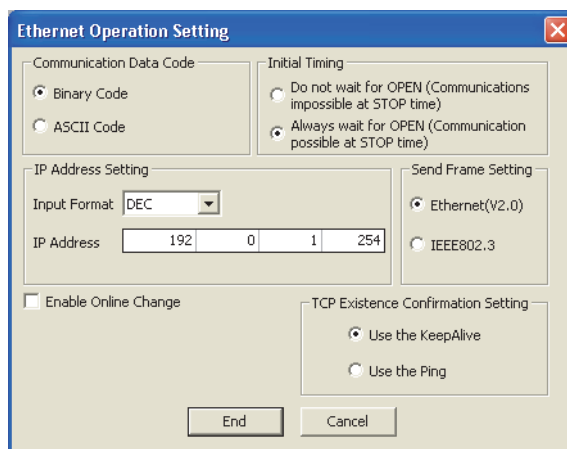

- *3 MELSECNET/H, MELSECNET/10 relay exchange
On the L series, Ethernet parameters (network number and station number) using the EPRSET instruction cannot be set. When the EPRSET instruction is in use, delete the sequence program of the corresponding section, and set the Ethernet parameters in the GX Works2 network parameters.
- *4 Communications using pairing open
On the L series, the pairing open setting of connection No.8 and 16 is not possible.
(The QnAS series supported the pairing open setting of connection No. 8 for receiving and connection No. 1 for sending.)
When the pairing open setting of connection No.8 has been made, change the sequence program.
On the L series, the pairing open settings of connection No.1 to 7, and 9 to 15 are possible.

3.4 Switch Setting Comparison

(1) Comparison between AnS series and L series

○ : Compatible, △ : Partial change required, × : Incompatible

Switch name		Description		Compatibility	Precautions for replacement	
		AnS series	L series			
		A1SJ71E71N3-T A1SJ71E71N-B5 A1SJ71E71N-B2	LJ71E71-100			
Operation mode setting switch		Selects the operation mode. 0: Online 1: Offline 2: Test 1 (self-loopback test) 3: Test 2 (RAM test) 4: Test 3 (ROM test)	–	△	Set in the GX Works2 network parameters. (1) in *1)	
Exchange condition setting switch	SW1	Selection of line processing at a TCP timeout error	Selects line processing when a TCP ULP timeout error occurs. OFF: Closes the line ON: Does not close the line	–	△	Closes the line when a TCP ULP timeout error occurs.
	SW2	Data code setting	Selects the communications data code type. OFF: Binary code ON: ASCII code	–	△	Set in the GX Works2 network parameters. (2) in *1)
	SW7	CPU communications timing setting	Selects write during RUN enable/disable. OFF: Write during RUN disabled ON: Write during RUN enabled	–	△	Set in the GX Works2 network parameters. (3) in *1)
	SW8	Initial timing	Selects the initial processing startup timing. OFF: Quick start ON: Normal start	–	△	A quick start is performed (Initial processing starts up with no delay time.)

*1 GX Works2 network parameters

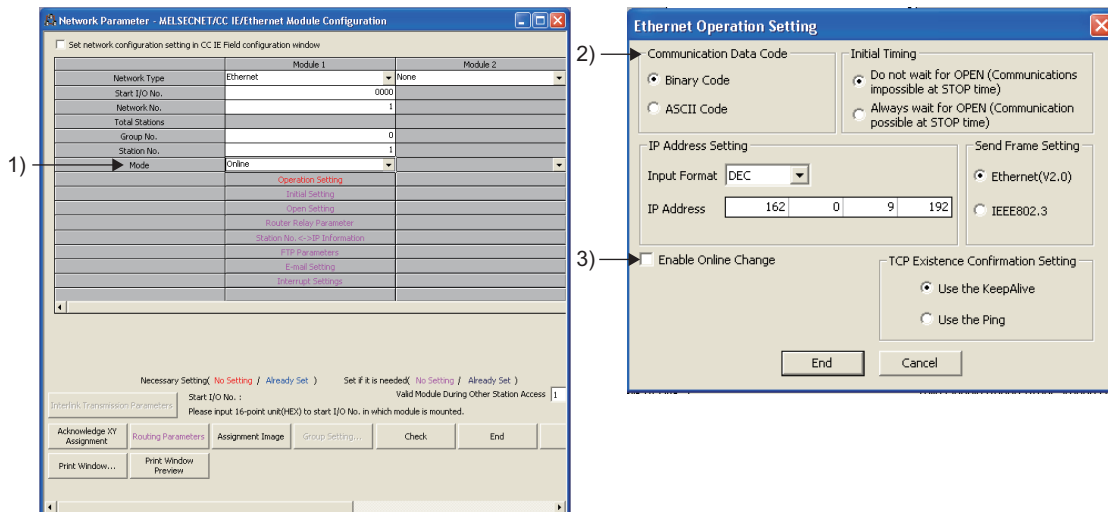

(2) Comparison between QnAS series and L series

○ : Compatible, △ : Partial change required, × : Incompatible

Switch name			Description		Compatibility	Precautions for replacement
			QnAS series	L series		
			A1SJ71QE71N3-T A1SJ71QE71N-B5 A1SJ71QE71N-B2	LJ71E71-100		
Operation mode setting switch			Selects the operation mode. 0: Online 1: Offline 2: Test 1 (self-loopback test) 3: Test 2 (RAM test) 4: Test 3 (ROM test) 5: Test 4 (E ² PROM test)	-	△	Set in the GX Works2 network parameters. (1) in *1)
Exchange condition setting switch	SW1	Selection of line processing at a TCP timeout error	Selects line processing when a TCP ULP timeout error occurs. OFF: Closes the line ON: Does not close the line	-	△	Closes the line when a TCP ULP timeout error occurs.
	SW2	Data code setting	Selects the communications data code type. OFF: Binary code ON: ASCII code	-	△	Set in the GX Works2 network parameters. (2) in *1)
	SW3	Automatic startup mode setting	Selects the startup method when a module is started. OFF: Operation follows Y19 ON: Operation regardless of Y19	-	△	Operation follows the setting of Y19.*2
	SW7	CPU communications timing setting	Selects write during RUN enable/disable. OFF: Write during RUN disabled ON: Write during RUN enabled	-	△	Set in the GX Works2 network parameters. (3) in *1)
	SW8	Initial timing	Selects the initial processing startup timing. OFF: Quick start ON: Normal start	-	△	A quick start is performed (Initial processing starts up with no delay time.)

*1 GX Works2 network parameters

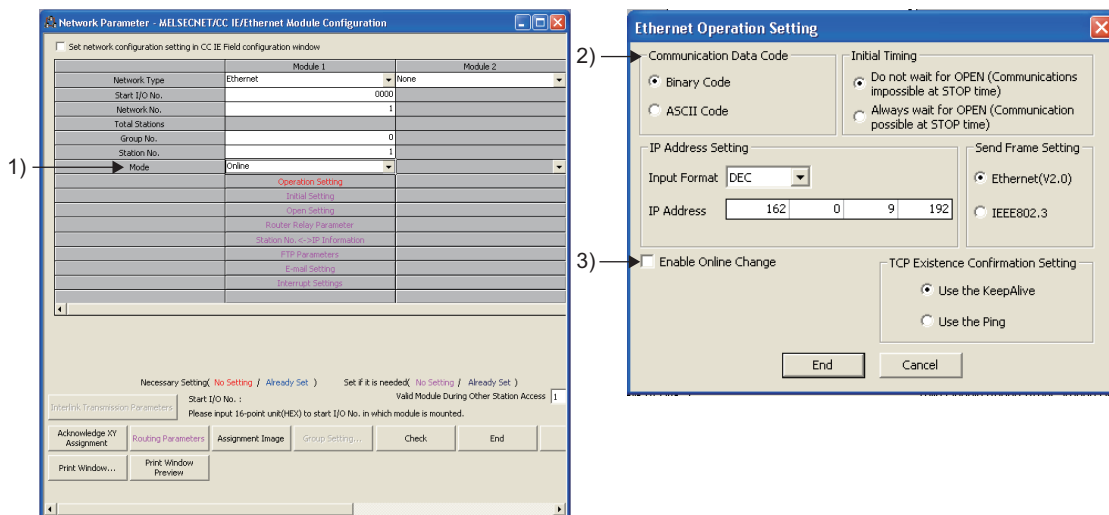

*2 When performing initial processing using GX Works2 network parameters, initial processing is executed automatically. (There is no need for a sequence program for initial processing/end processing.)

3.5 Parameter Comparison

(1) Comparison between AnS series and L series

On the AnS series, the parameters of the Ethernet interface module are set in the buffer memory. On the L series, however, the parameters are set using GX Works2 network parameters. Therefore, there is no compatibility between the parameters of the AnS series and the L series. When replacing the AnS series with the L series, delete the parameter settings of the AnS series and set new parameters on GX Works2.

(2) Comparison between QnAS series and L series

○ : Compatible, △ : Partial change required, × : Incompatible

Parameter name	Description		Compatibility	Precautions for replacement
	QnAS series	L series		
	A1SJ71QE71N3-T A1SJ71QE71N-B5 A1SJ71QE71N-B2	LJ71E71-100		
Network parameter	Network type		○	
	Start I/O No.		○	
	Network No.		○	
	Group No.		○	
	Station No.		○	
	-	Mode	△	On the QnAS series, the mode was set on the operation mode setting switch.
	IP address setting	Operational setting	○	
	-	Initial settings	△	On the QnAS series, the setting was set in the sequence program.
	-	Open settings	△	
	Station No. <-> IP information		○	
	FTP Parameters		○	
	Router relay parameter		○	
	Routing parameter		○	

3.6 Program Comparison

3.6.1 I/O signal

(1) Comparison between AnS series and L series

○ : Compatible, △ : Partial change required, × : Incompatible

Input signal	Signal name		Compatibility	Precautions for replacement
	AnS series	L series		
	A1SJ71E71N3-T A1SJ71E71N-B5 A1SJ71E71N-B2	LJ71E71-100		
Xn0	Transmission normal end or reception end (For connection No.1)		○	
Xn1	Transmission error detection or reception error detection (For connection No.1)		○	
Xn2	Transmission normal end or reception end (For connection No.2)		○	
Xn3	Transmission error detection or reception error detection (For connection No.2)		○	
Xn4	Transmission normal end or reception end (For connection No.3)		○	
Xn5	Transmission error detection or reception error detection (For connection No.3)		○	
Xn6	Transmission normal end or reception end (For connection No.4)		○	
Xn7	Transmission error detection or reception error detection (For connection No.4)		○	
Xn8	Transmission normal end or reception end (For connection No.5)		○	
Xn9	Transmission error detection or reception error detection (For connection No.5)		○	
XnA	Transmission normal end or reception end (For connection No.6)		○	
XnB	Transmission error detection or reception error detection (For connection No.6)		○	
XnC	Transmission normal end or reception end (For connection No.7)		○	
XnD	Transmission error detection or reception error detection (For connection No.7)		○	
XnE	Transmission normal end or reception end (For connection No.8)		○	
XnF	Transmission error detection or reception error detection (For connection No.8)		○	
X(n+1)0	Open end (For connection No.1)		○	
X(n+1)1	Open end (For connection No.2)		○	
X(n+1)2	Open end (For connection No.3)		○	
X(n+1)3	Open end (For connection No.4)		○	
X(n+1)4	Open end (For connection No.5)		○	
X(n+1)5	Open end (For connection No.6)		○	
X(n+1)6	Open end (For connection No.7)		○	
X(n+1)7	Open end (For connection No.8)		○	
X(n+1)8	Open error detection		○	
X(n+1)9	Initial normal end		○	
X(n+1)A	Initial error end		○	
X(n+1)B	Use prohibited		○	
X(n+1)C	COM. ERR LED ON		○	
X(n+1)D	Use prohibited		○	
X(n+1)E			○	
X(n+1)F	Watchdog timer error detection		○	

○ : Compatible, △ : Partial change required, × : Incompatible

Output signal	Signal name		Compatibility	Precautions for replacement
	AnS series	L series		
	A1SJ71E71N3-T A1SJ71E71N-B5 A1SJ71E71N-B2	LJ71E71-100		
Yn0	Transmission request or reception end check (For connection No.1)		○	
Yn1	Transmission request or reception end check (For connection No.2)		○	
Yn2	Transmission request or reception end check (For connection No.3)		○	
Yn3	Transmission request or reception end check (For connection No.4)		○	
Yn4	Transmission request or reception end check (For connection No.5)		○	
Yn5	Transmission request or reception end check (For connection No.6)		○	
Yn6	Transmission request or reception end check (For connection No.7)		○	
Yn7	Transmission request or reception end check (For connection No.8)		○	
Yn8	Open request (For connection No.1)		○	
Yn9	Open request (For connection No.2)		○	
YnA	Open request (For connection No.3)		○	
YnB	Open request (For connection No.4)		○	
YnC	Open request (For connection No.5)		○	
YnD	Open request (For connection No.6)		○	
YnE	Open request (For connection No.7)		○	
YnF	Open request (For connection No.8)		○	
Y(n+1)0	Use prohibited		○	
Y(n+1)1			○	
Y(n+1)2			○	
Y(n+1)3			○	
Y(n+1)4			○	
Y(n+1)5			○	
Y(n+1)6			○	
Y(n+1)7	COM. ERR LED OFF request		○	
Y(n+1)8	Use prohibited		○	
Y(n+1)9	Initial request		○	
Y(n+1)A	Use prohibited		○	
Y(n+1)B			○	
Y(n+1)C	Buffer memory channel switching	Use prohibited	△	Buffer memory channel setting is not required. Delete the sequence program of the section corresponding to the function.
Y(n+1)D	Use prohibited		○	
Y(n+1)E			○	
Y(n+1)F			○	

(2) Comparison between QnAS series and L series

○ : Compatible, △ : Partial change required, × : Incompatible

Input signal	Signal name		Compatibility	Precautions for replacement
	QnAS series	L series		
	A1SJ71QE71N3-T A1SJ71QE71N-B5 A1SJ71QE71N-B2	LJ71E71-100		
Xn0	Transmission normal end or reception end (For connection No.1)		○	
Xn1	Transmission error detection or reception error detection (For connection No.1)		○	
Xn2	Transmission normal end or reception end (For connection No.2)		○	
Xn3	Transmission error detection or reception error detection (For connection No.2)		○	
Xn4	Transmission normal end or reception end (For connection No.3)		○	
Xn5	Transmission error detection or reception error detection (For connection No.3)		○	
Xn6	Transmission normal end or reception end (For connection No.4)		○	
Xn7	Transmission error detection or reception error detection (For connection No.4)		○	
Xn8	Transmission normal end or reception end (For connection No.5)		○	
Xn9	Transmission error detection or reception error detection (For connection No.5)		○	
XnA	Transmission normal end or reception end (For connection No.6)		○	
XnB	Transmission error detection or reception error detection (For connection No.6)		○	
XnC	Transmission normal end or reception end (For connection No.7)		○	
XnD	Transmission error detection or reception error detection (For connection No.7)		○	
XnE	Transmission normal end or reception end (For connection No.8)		○	
XnF	Transmission error detection or reception error detection (For connection No.8)		○	
X(n+1)0	Open end (For connection No.1)		○	
X(n+1)1	Open end (For connection No.2)		○	
X(n+1)2	Open end (For connection No.3)		○	
X(n+1)3	Open end (For connection No.4)		○	
X(n+1)4	Open end (For connection No.5)		○	
X(n+1)5	Open end (For connection No.6)		○	
X(n+1)6	Open end (For connection No.7)		○	
X(n+1)7	Open end (For connection No.8)		○	
X(n+1)8	Open error detection		○	
X(n+1)9	Initial normal end		○	
X(n+1)A	Initial error end		○	
X(n+1)B	Use prohibited		○	
X(n+1)C	COM. ERR LED ON		○	
X(n+1)D	E ² PROM read complete	Use prohibited	△	No E ² PROM (Refer to Section 3.8.)
X(n+1)E	E ² PROM write complete		△	
X(n+1)F	Watchdog timer error detection		○	

○ : Compatible, △ : Partial change required, × : Incompatible

Output signal	Signal name		Compatibility	Precautions for replacement
	QnAS series	L series		
	A1SJ71QE71N3-T A1SJ71QE71N-B5 A1SJ71QE71N-B2	LJ71E71-100		
Yn0	Transmission request or reception end check (For connection No.1)		○	
Yn1	Transmission request or reception end check (For connection No.2)		○	
Yn2	Transmission request or reception end check (For connection No.3)		○	
Yn3	Transmission request or reception end check (For connection No.4)		○	
Yn4	Transmission request or reception end check (For connection No.5)		○	
Yn5	Transmission request or reception end check (For connection No.6)		○	
Yn6	Transmission request or reception end check (For connection No.7)		○	
Yn7	Transmission request or reception end check (For connection No.8)		○	
Yn8	Open request (For connection No.1)		○	
Yn9	Open request (For connection No.2)		○	
YnA	Open request (For connection No.3)		○	
YnB	Open request (For connection No.4)		○	
YnC	Open request (For connection No.5)		○	
YnD	Open request (For connection No.6)		○	
YnE	Open request (For connection No.7)		○	
YnF	Open request (For connection No.8)		○	
Y(n+1)0	E ² PROM read request	Use prohibited	△	No E ² PROM (Refer to Section 3.8.)
Y(n+1)1	E ² PROM write request		△	
Y(n+1)2	Use prohibited		○	
Y(n+1)3			○	
Y(n+1)4			○	
Y(n+1)5			○	
Y(n+1)6			○	
Y(n+1)7			COM. ERR LED OFF request	
Y(n+1)8	Use prohibited		○	
Y(n+1)9	Initial request		○	
Y(n+1)A	Use prohibited		○	
Y(n+1)B			○	
Y(n+1)C			○	
Y(n+1)D			○	
Y(n+1)E			○	
Y(n+1)F			○	

3.6.2 Buffer memory

(1) Comparison between AnS series and L series

There is no compatibility in the buffer memory assignments between the AnS series and the L series. Make a new sequence program.

○ : Compatible, △ : Partial change required, × : Incompatible

AnS series			Compatibility	Precautions for replacement
Buffer memory address		Buffer memory name		
HEX	DEC	A1SJ71E71N3-T A1SJ71E71N-B5 A1SJ71E71N-B2		
0 to 1 _H	0 to 1	Local station IP address	△	Set in GX Works2 network parameters.
2 _H	2	Special function setting	△	
3 _H	3	Timer setting time units	△	Not used on the L series.
4 to 5 _H	4 to 5	System area (Use prohibited)	–	
6 _H	6	TCP Maximum Segment transmission setting	△	1E _H (30) is used on the L series.
7 _H	7	Destination existence check start interval timer value	△	Set in GX Works2 network parameters.
8 _H	8	Destination existence check interval timer value	△	
9 _H	9	Destination existence check, No. of retries	△	
A _H	10	TCP ULP timeout value	△	
B _H	11	TCP zero window timer value	△	
C _H	12	TCP retransmit timer value	△	
D _H	13	TCP end timer value	△	
E _H	14	IP reassembly timer value	△	
F _H	15	Response monitoring timer value	△	
10 to 17 _H	16 to 23	Application setting area (Connection No.1 to 8)	△	
18 to 4F _H	24 to 79	Exchange address settings area (Connection No.1 to 8)	△	
50 _H	80	Initial error code	△	69 _H (105) is used on the L series.
51 to 52 _H	81 to 82	Local station IP address	△	6A to 6B _H (106 to 107) is used on the L series.
53 to 55 _H	83 to 85	Local station Ethernet address	△	6C to 6E _H (108 to 110) is used on the L series.
56 to 58 _H	86 to 88	System area (Use prohibited)	–	
59 to A8 _H	89 to 168	Information for each connection (Connection No.1 to 8)	△	78 to C7 _H (120 to 199) is used on the L series.
A9 to B3 _H	169 to 179	Error log 1 to 11	△	E5 to 174 _H (229 to 372) is used on the L series.
B4 to 16F _H	180 to 367	System area (Use prohibited)	–	
170 to 1A3 _H	368 to 419	Status information by protocol type	△	178 to 1E1 _H (376 to 481) is used on the L series.
1A4 to 1BF _H	420 to 447	System area (Use prohibited)	–	
1C0 to 1C1 _H	448 to 449	Subnet mask field	△	Set in GX Works2 network parameters.
1C2 to 1C3 _H	450 to 451	Default router IP address	△	
1C4 _H	452	No. of registered routers	△	
1C5 to 1D8 _H	453 to 472	Setting of router 1 to 5	△	
1D9 to 1EF _H	473 to 495	System area (Use prohibited)	–	
1F0 _H	496	Communication specification during STOP	△	Not used on the L series.
1F1 to 1FF _H	497 to 511	System area (Use prohibited)	–	
200 to 11FF _H	512 to 4607	Fixed buffer No.1 to 8	△	680 to 267F _H (1664 to 9855) is used on the L series.
1200 to 1DFF _H	4608 to 7679	Random access buffer	△	2680 to 3E7F _H (9856 to 15999) is used on the L series.

(2) Comparison between QnAS series and L series

The buffer memory assignment of the QnAS series is compatible with that of the L series.
The sequence program of the QnAS series can be used as is.

○ : Compatible, △ : Partial change required, × : Incompatible

Buffer memory address		Buffer memory name		Compatibility	Precautions for replacement
HEX	DEC	QnAS series	L series		
		A1SJ71QE71N3-T A1SJ71QE71N-B5 A1SJ71QE71N-B2	LJ71E71-100		
0 to 1 _H	0 to 1	Local station IP address		○	
2 to 3 _H	2 to 3	System area (Use prohibited)		○	
4 _H	4	Special function setting		○	
5 to A _H	5 to 10	System area (Use prohibited)		○	
B to 13 _H	11 to 19	Monitoring timer		○	
14 _H	20	Automatically open UDP port No.		○	
15 to 1D _H	21 to 29	System area (Use prohibited)		○	
1E _H	30	TCP Maximum Segment transmission setting		○	
1F _H	31	System area (Use prohibited)	Exchange condition setting	○	
20 to 27 _H	32 to 39	Application setting area (Connection No.1 to 8)		○	
28 to 5F _H	40 to 95	Exchange address settings area (Connection No.1 to 8)		○	
60 to 66 _H	96 to 102	System area (Use prohibited)		○	
67 _H	103	Communication specification during STOP	System area (Use prohibited)	△	Delete the sequence program.
68 _H	104	E ² PROM parameter portion specification		△	
69 _H	105	Initial error code		○	
6A to 6B _H	106 to 107	Local station IP address		○	
6C to 6E _H	108 to 110	Local station Ethernet address		○	
6F _H	111	System area		○	
70 _H	112	E ² PROM register status	System area (Use prohibited)	△	Delete the sequence program.
71 _H	113	Parameter use status		△	
72 _H	114	E ² PROM read result		△	
73 _H	115	E ² PROM write result		△	
74 _H	116	Automatically open UDP port No.		○	
75 _H	117	System area (Use prohibited)		○	
76 _H	118	Network No./Station No.		○	
77 _H	119	Group No.		○	
78 to C7 _H	120 to 199	Information for each connection (Connection No.1 to 8)		○	
C8 _H	200	LED ON status (Left side)	LED ON status	△	Check the LED ON status at C8 _H (200).
C9 _H	201	LED ON status (Right side)	Hub connection status area	△	
CA _H	202	Operation mode setting switch status		○	
CB _H	203	Exchange condition setting switch status	GX Works2 setting status	△	Stores the setting status of the GX Works2 network parameters.
CC _H	204	System area (Use prohibited)		○	
CD _H	205	RECV instruction execution request		○	
CE _H	206	System area (Use prohibited)		○	
CF to DF _H	207 to 223	Data link command execution result by channel		△	Stores the execution result of the ZNRD, ZNWR instructions.
E0 to E2 _H	224 to 226	System area (Use prohibited)		○	
E3 _H	227	No. of errors generated		○	
E4 _H	228	Error log write pointer		○	
E5 to 174 _H	229 to 372	Error log block 1 to 16		○	
175 to 177 _H	373 to 375	System area (Use prohibited)		○	

○: Compatible, △: Partial change required, ×: Incompatible

Buffer memory address		Buffer memory name		Compatibility	Precautions for replacement
HEX	DEC	QnAS series	L series		
		A1SJ71QE71N3-T A1SJ71QE71N-B5 A1SJ71QE71N-B2	LJ71E71-100		
178 to 1FF _H	376 to 511	Status information by protocol type		△	Some assignments differ. For details, refer to the MELSEC-L Ethernet Interface Module User's Manual (Basic).
200 to 201 _H	512 to 513	Subnet mask field		○	
202 to 203 _H	514 to 515	Default router IP address		○	
204 _H	516	No. of registered routers		○	
205 to 224 _H	517 to 548	Setting of router 1 to 8		○	
225 to 227 _H	549 to 551	System area (Use prohibited)		○	
228 _H	552	Number of conversion table data		○	
229 to 3A8 _H	553 to 936	Conversion information No.1 to 64		○	
3A9 to 3AA _H	937 to 938	Net mask pattern for MELSECNET/10 routing		○	
3AB to 3AF _H	939 to 943	System area (Use prohibited)		○	
3B0 to 67F _H	944 to 1663	FTP setting		△	The default log-in name and password have been changed from "AJ71QE71" to "LJ71E71". Set in GX Works2 network parameters.
680 to 267F _H	1664 to 9855	Fixed buffer No.1 to 8		○	
2680 to 3E7F _H	9856 to 15999	Random access buffer		○	

3.7 Reuse of Existing Programs

(1) AnS series

○ : Compatible, △ : Partial change required, × : Incompatible

Item	Compatibility		Precautions for replacement
	Program (Communication target device)	Sequence program (Ethernet Interface module)	
Communications using fixed buffer (procedural, nonprocedural)	○	△	[Programmable controller side] The sequence program is not compatible as buffer memory assignments differ. Change to a sequence program that uses the dedicated instructions (BUFSND, BUFRVCV).
Communications using random access buffer	○	△	[Programmable controller side] The sequence program is not compatible as buffer memory assignments differ. Check the buffer memory assignments and change the sequence program.
Read/write communications of programmable controller CPU internal data	△	—	[Communication target device side] Some of the commands and device ranges are restricted.*1

*1 Read/write communications of programmable controller CPU internal data

(1) On the L series, some commands (batch read/writer of microcomputer) are not usable.

For details, refer to the MELSEC-Q/L MELSEC Communication Protocol Reference Manual.

(2) Devices of the same name only that exist on the AnS series programmable controller CPU can be read/written within the device ranges of AnACPU.

The following devices cannot be accessed from external devices:

- Devices newly added on by LCPU
- Latch relays (L) and step relays (S)

(In the case of LCPU, the internal relays (M), the latch relays (L) and step relays (S) of other devices can not be specified as target devices to be accessed.)

- File registers (R)

(3) The following devices are accessed on special relays (M9000 onwards) and special registers (D9000 onwards):

- SD1000 to SD1255 are accessed by specifying D9000 to D9255.
- SM1000 to SM1255 are accessed by specifying M9000 to M9255.

(2) QnAS series

○ : Compatible, △ : Partial change required, × : Incompatible

Item	Compatibility		Precautions for replacement
	Program (Communication target device)	Sequence program (Ethernet Interface module)	
Communications using fixed buffer (procedural, nonprocedural)	○	○	
Communications using random access buffer	○	○	
Read/write of programmable controller CPU internal data	△	–	[Communication target device side] Some of the commands and device ranges are restricted.*1
Communications using data link instructions	○	○	
File transfer (FTP server functions)	△	–	[Communication target device side] The default log-in name and password have been changed from "AJ71QE71" to "LJ71E71", so set the log-in name again.

*1 Read/write of programmable controller CPU internal data

(1) Commands relating to file operations on LCPU differ from commands for QnACPU.

For details, refer to the MELSEC communication protocol reference manual.

(2) The program for accessing the programmable controller CPU in the data link system cannot be used.

(The LCPU cannot be connected to MELSECNET (II) and MELSECNET/B.)

3.8 Other Precaution

(1) Parameter registration to E²PROM

As the L series Ethernet interface module does not have an E²PROM, delete the sequence program of the section corresponding to parameter registration to E²PROM.

On the L series Ethernet interface module, set the GX Works2 network parameters to save parameters to the programmable controller CPU.

(2) Initial processing/end processing

Initial processing using GX Works2 network parameters cannot be used jointly with initial processing/end processing using the sequence program.

When using GX Works2 network parameters, delete processing by the sequence program.

(3) Open processing/close processing

Do not use open processing/close processing using I/O signals with open/close processing using dedicated instructions (OPEN/CLOSE) in the same connection.

(4) Passive open processing

The L series Ethernet interface module cannot cancel open requests before an open end after passive open processing is executed.

Perform close processing after an open end.

(5) Communications using fixed buffer

Do not use fixed buffer communication using I/O signals and fixed buffer communication using dedicated instructions (BUFSND/BUFRCV/BUFRCVS) in the same connection.

(6) About processing time

The data communications processing time differs on the AnS/QnAS series modules and L series modules.

For this reason, the data communications timing, etc. also differ.

If necessary, adjust the timing by inserting a wait time, for example.

For actual details on processing times, refer to the manual for the respective module.

(7) Replacement of the 10BASE5/10BASE2 with the 10BASE-T

The AnS/QnAS series 10BASE5/10BASE2 module is required to be also replaced with the L series 10BASE-T module. Note that a media converter is required.

3.9 Program Examples

The following shows a program example at transition from the AnS series to the L series. When applying the program example introduced in this section to an actual program, sufficiently study if there will be any problem in control on the target system.

(1) System configuration

The following shows the system configuration used in the program example in this section.

(a) AnS series

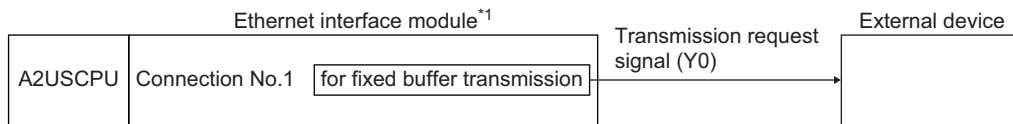

(b) L series

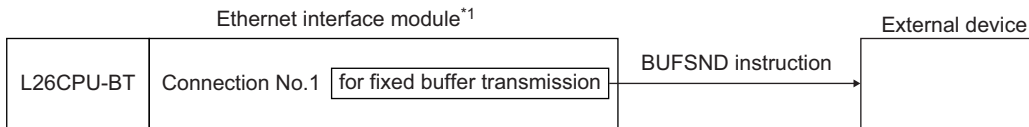

*1 The I/O signals of the Ethernet interface module shall be X/Y0 to X/Y1F.

3.9.1 Initial processing

The following shows a program example for performing initial processing.

(1) AnS series

The AnS series performs initial processing by writing parameters for initial processing by the sequence program to buffer memory and turning the initial request signal (Y19) ON.

(a) Program conditions

The following shows a program example for performing initial processing when the communication start instruction (X40) is turned ON.

Set the parameters for initial processing as follows. (Otherwise, use default values.)

Buffer memory address	Item	Set value
DEC (HEX)		
0 to 1(0 to 1 _H)	Local station IP address	A20009C0 _H (162.0.9.192)

(b) Program example

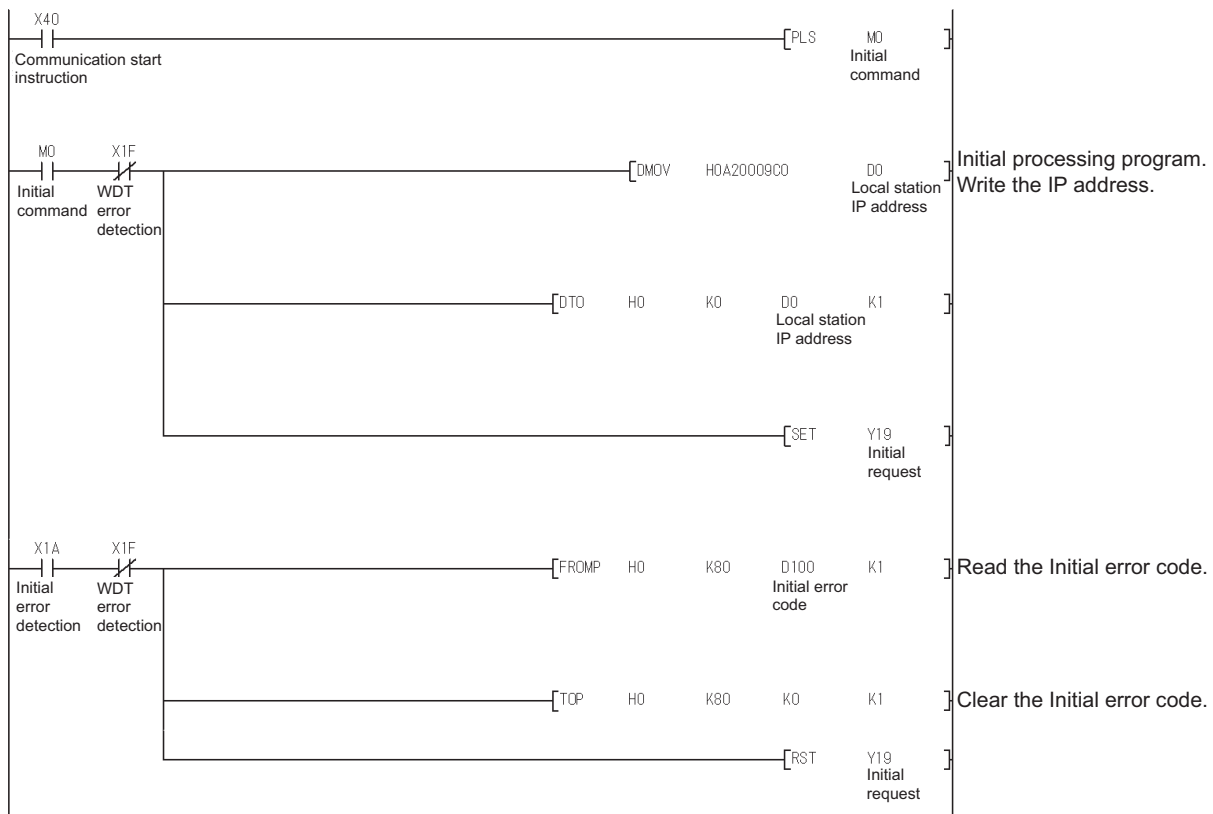

☒ Point

On the L series, the parameter for initial processing is set using GX Works2 network parameters. When replacing the AnS series with the L series, refer to (1)(b) to delete the program where the parameter for initial processing is set and set the parameter using GX Works2 network parameters.

(2) L series

The L series performs initial processing by setting the following items in the GX Works2 network parameters.

- Settings from "Network Type" to "Mode"
- "Operation Setting"
- "Initial Setting"

When replacing the AnS series with the L series, delete the AnS series' sequence program for initial processing.

(a) Program conditions

Set as follows in the GX Works2 network parameters:

IP address: A20009C0H(162.0.9.192)

Other than IP address: Use default values.

(b) Network parameter setting example

1) "Network Parameter - MELSECNET/CC IE/Ethernet Module Configuration"

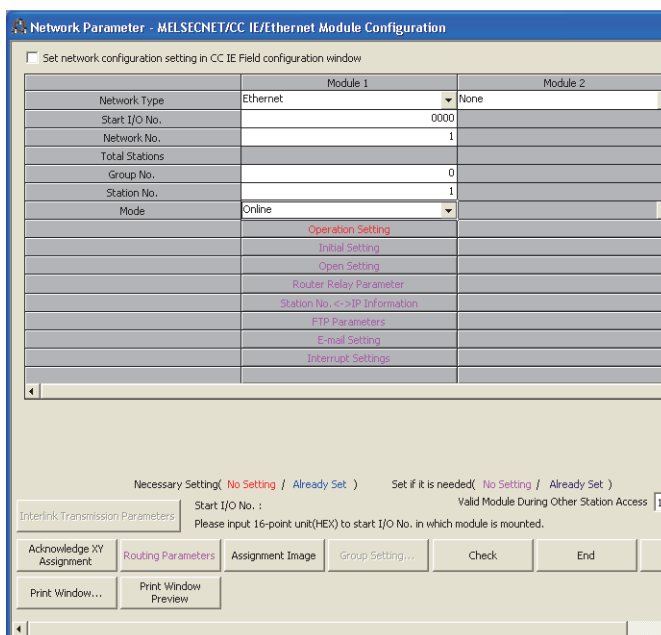

2) "Operation Setting"

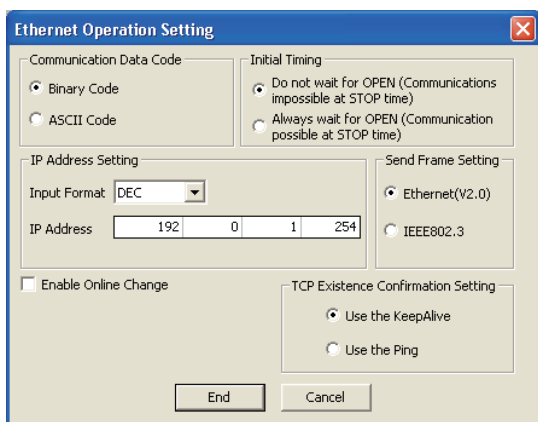

3) "Initial Setting"

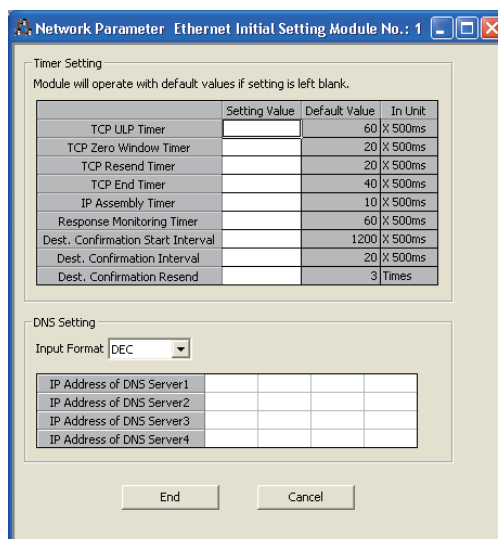

3.9.2 Open/close processing

The following shows a program example for performing open processing/close processing.

(1) AnS series

[Open processing]

The AnS series performs initial processing by writing communication parameters for initial processing by the sequence program to buffer memory and turning Open request signal (Y8) ON.

[Close processing]

The AnS series performs close processing by turning Open request signal (Y8) OFF, or by the close request (FIN) from an external device.

(a) Program conditions

The following shows a program example for performing open processing (unpassive open) on connection No.1 when initial normal end (X19) turns ON.

Set the communication parameters as follows. (Otherwise, use default values.)

Buffer memory address DEC (HEX)	Item	Set value
16 (10 _H)	Connection No.1 application setting area	
	Sets the application of the fixed buffer (b0).	0: Transmission
	Destination existence check setting (b1)	0: No existence check
	Pairing open setting (b7)	0: Not pairing open
	Communication method (protocol)	0: TCP/IP
	Communication protocol setting (b8)	
	Communications using fixed buffer procedure performed/not performed (b9)	0: Performed
24 (18 _H)	Open method setting (b15, b14)	10: Unpassive open
	Host port number (For connection No.1)	500 _H

☒ Point

The open processing and the close processing on the L series have different methods from those on the AnS series.

When replacing the AnS series with the L series, refer to Section 3.9.2 (2) and change the program of the open processing and close processing.

(b) Program example

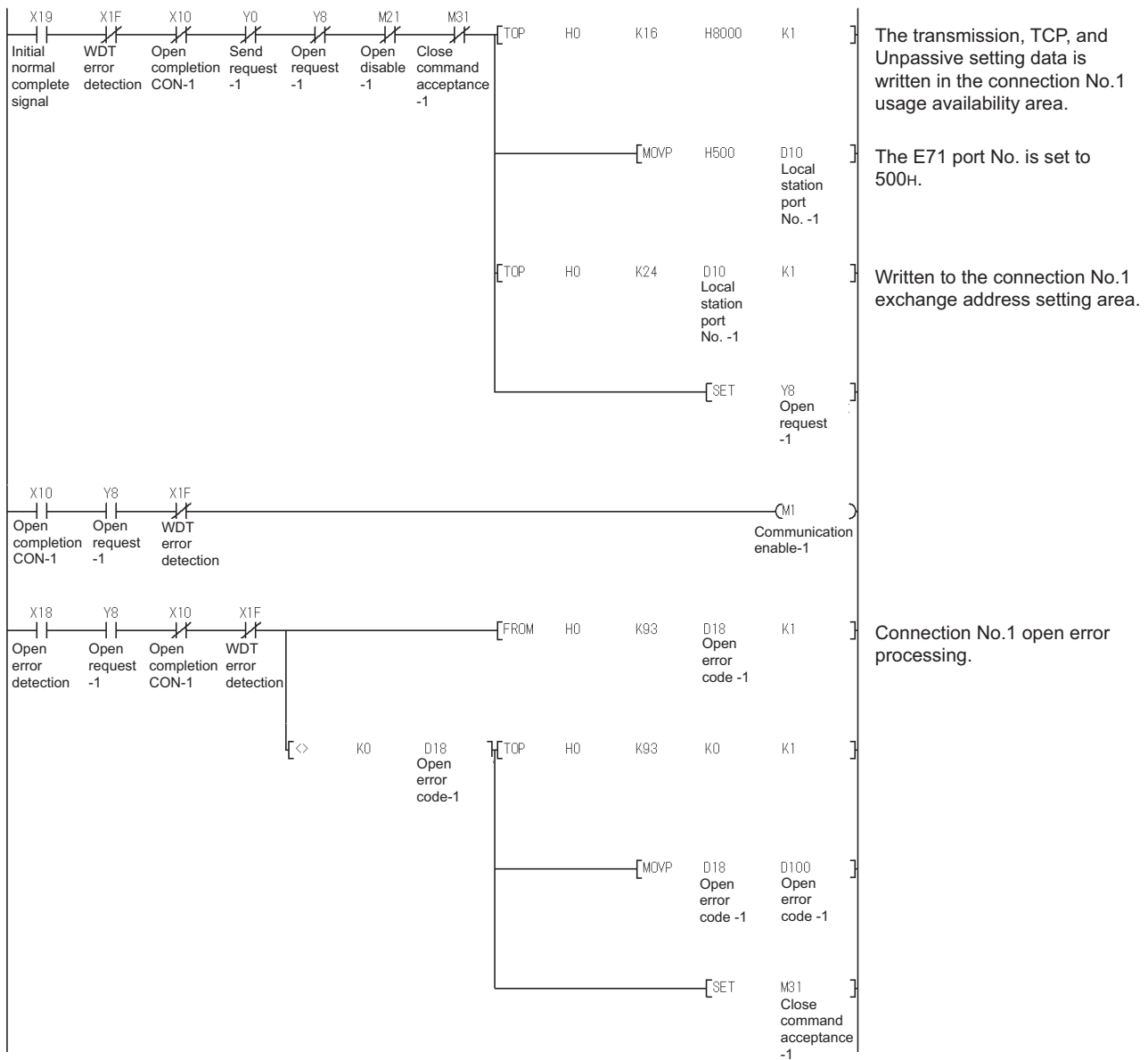

(2) L series

[Open processing]

The L series uses the dedicated instruction (OPEN) to perform open processing.

The communication parameters can be set using one of the following methods:

- In the control data of the dedicated instruction (OPEN)
- On GX Works2, select "Network Parameter" - "Ethernet / CC IE Field" - (Ethernet) - "Open Setting".

[Close processing]

The L series performs close processing by either using the dedicated instruction (CLOSE), or by the close request (FIN) from an external device.

(a) Program conditions

The following shows a program example for performing open processing (unpassive open) on connection No.1 when initial normal end (X19) turns ON with the initial normal end signal (M5000) ON.

Set the communication parameters in "Network Parameter" on GX Works2.

(b) Network parameter setting example

1) "Open Setting"

	Protocol	Open System	Fixed Buffer	Fixed Buffer Communication	Pairing Open	Existence Confirmation	Host Station Port No.	Destination IP Address	Destination Port No.
1	TCP	Unpassive	Send	Procedure Exist	Disable	No Confirm	0500		
2									
3									
4									
5									
6									
7									
8									
9									
10									
11									
12									
13									
14									
15									
16									

(*) IP Address and Port No. will be displayed by the selected format.
Please enter the value according to the selected number.

End Cancel

Point

When replacing the AnS series with the L series, change the open processing/close processing program of the AnS series to that of the L series.

(c) Program example

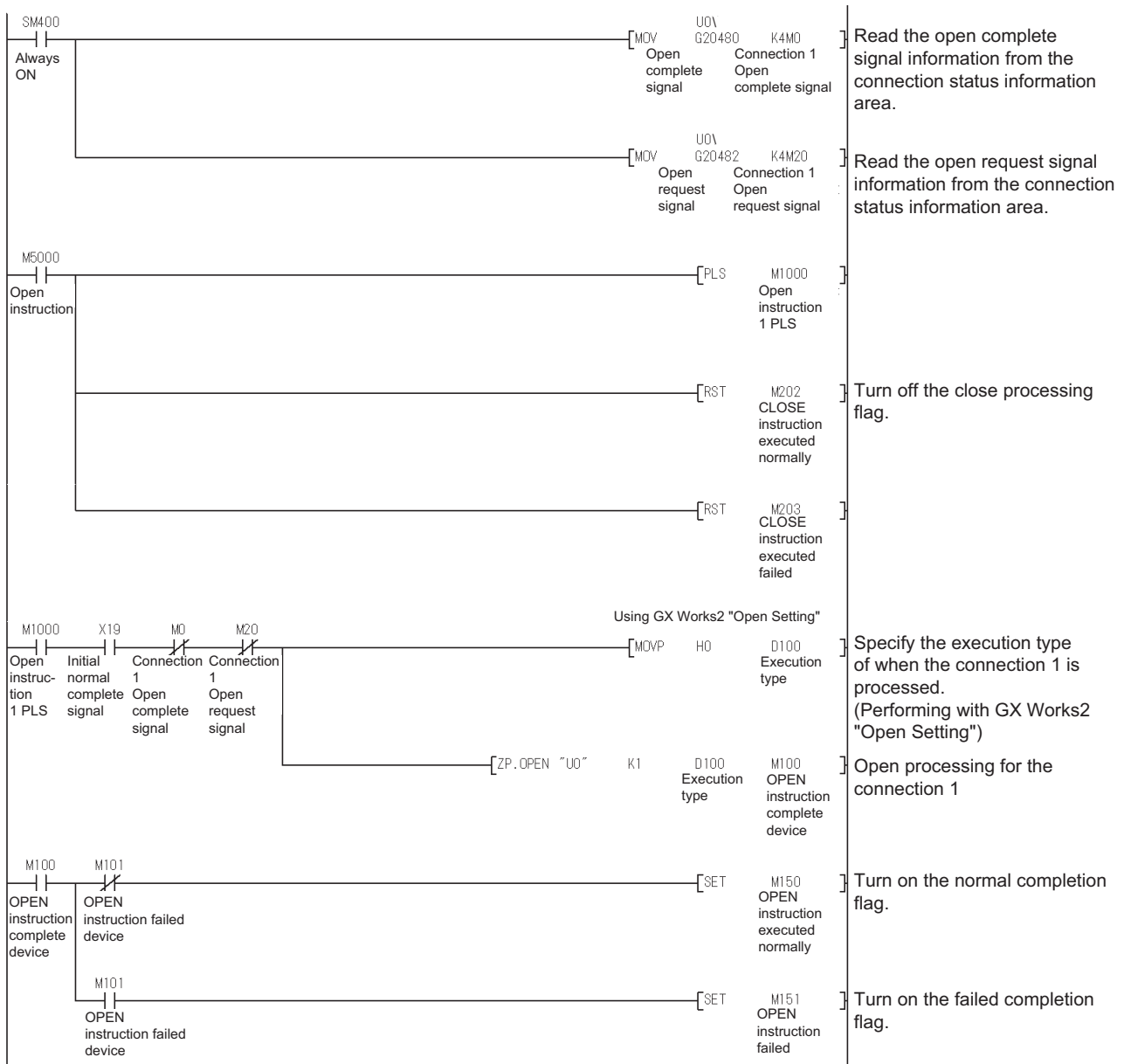

☒ Point

When "Operation Setting" - "Initial Timing" in GX Works2 is set to "Always wait for OPEN", the sequence program for open processing/close processing is not required.

3.9.3 Communication using fixed buffer

The following shows a program example for performing communication using fixed buffer.

(1) AnS series

[Transmission processing]

The AnS series performs data transmission processing to external devices from the fixed buffer by writing the send data to the fixed buffer area by the sequence program, and turning the send request signal (Y0) ON.

[Reception processing]

On the AnS series, the reception completion signal (X0) turns ON when data is received to the fixed buffer area.

The A/AnS series performs data reception processing by reading received data from the fixed buffer area by the sequence program, and turning the reception completion confirmation signal (Y0) ON.

(a) Program conditions

The following shows a program example for performing transmission processing by fixed buffer No.1 when the fixed buffer transmission instruction (X43) is turned ON.

(b) Program example

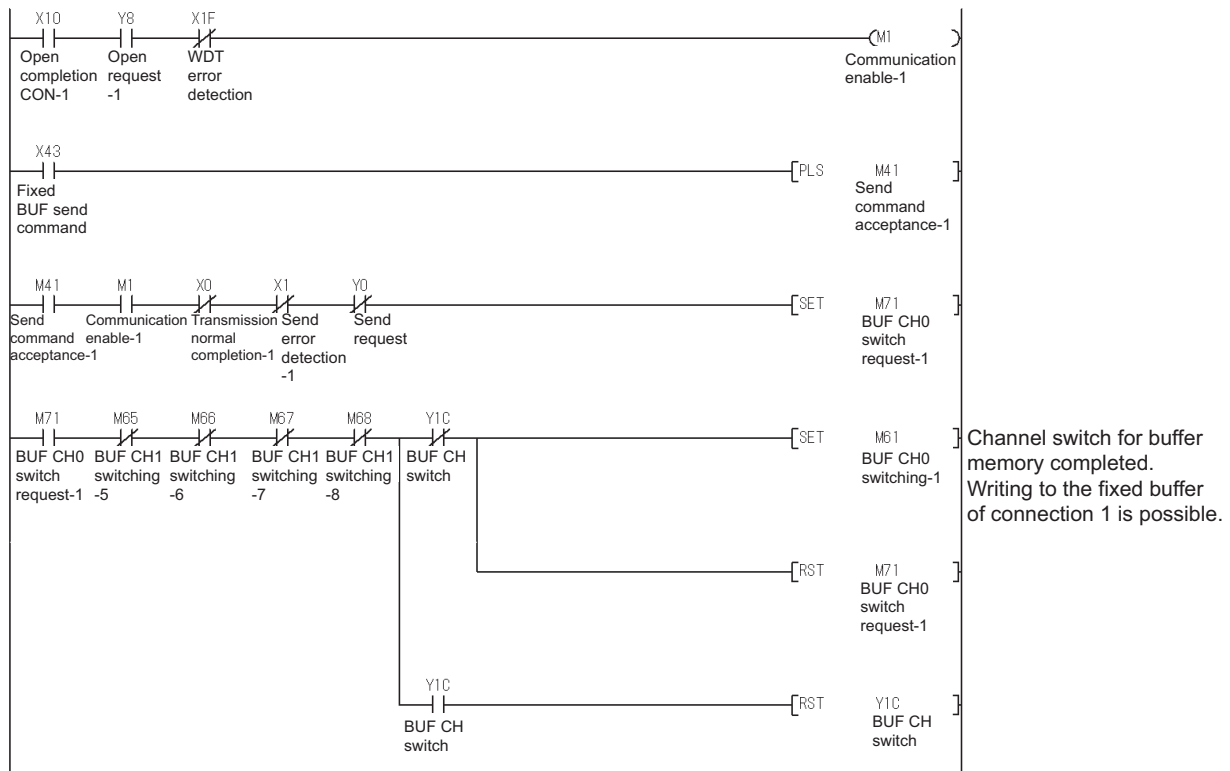

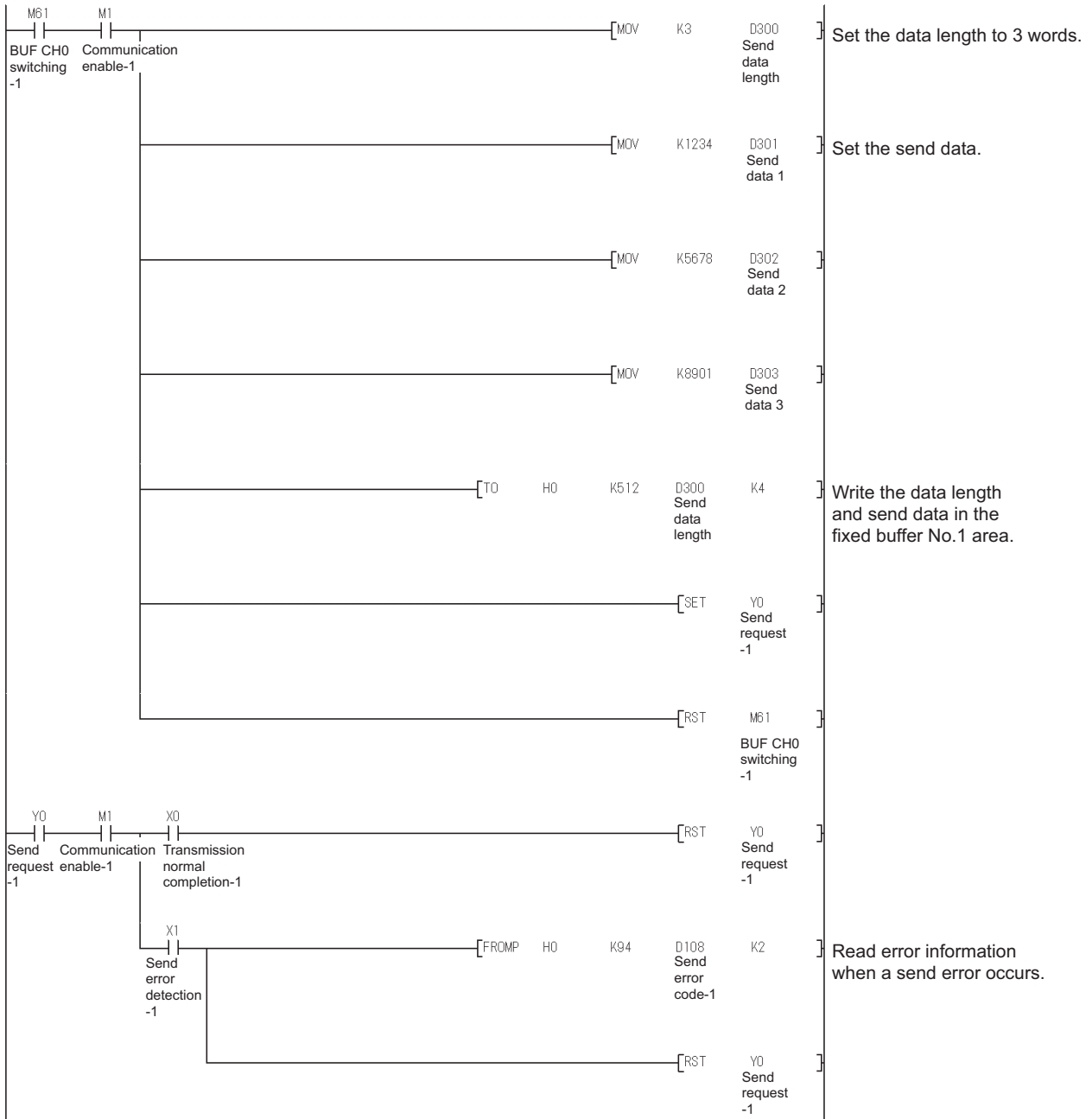

(2) L series

[Transmission processing]

The L series uses the dedicated instruction (BUFSND) to perform data transmission from the fixed buffer to an external device.

[Reception processing]

On the L series, the fixed buffer reception status signal (corresponding bit of address 5005_H) in buffer memory turns ON when data is received to the fixed buffer area.

The L series uses the dedicated instruction (BUFRCV) to perform data reception.

(a) Program conditions

The following shows a program example for performing transmission processing by fixed buffer No.1 when the transmission instruction (M7000) is turned ON.

(b) Program example

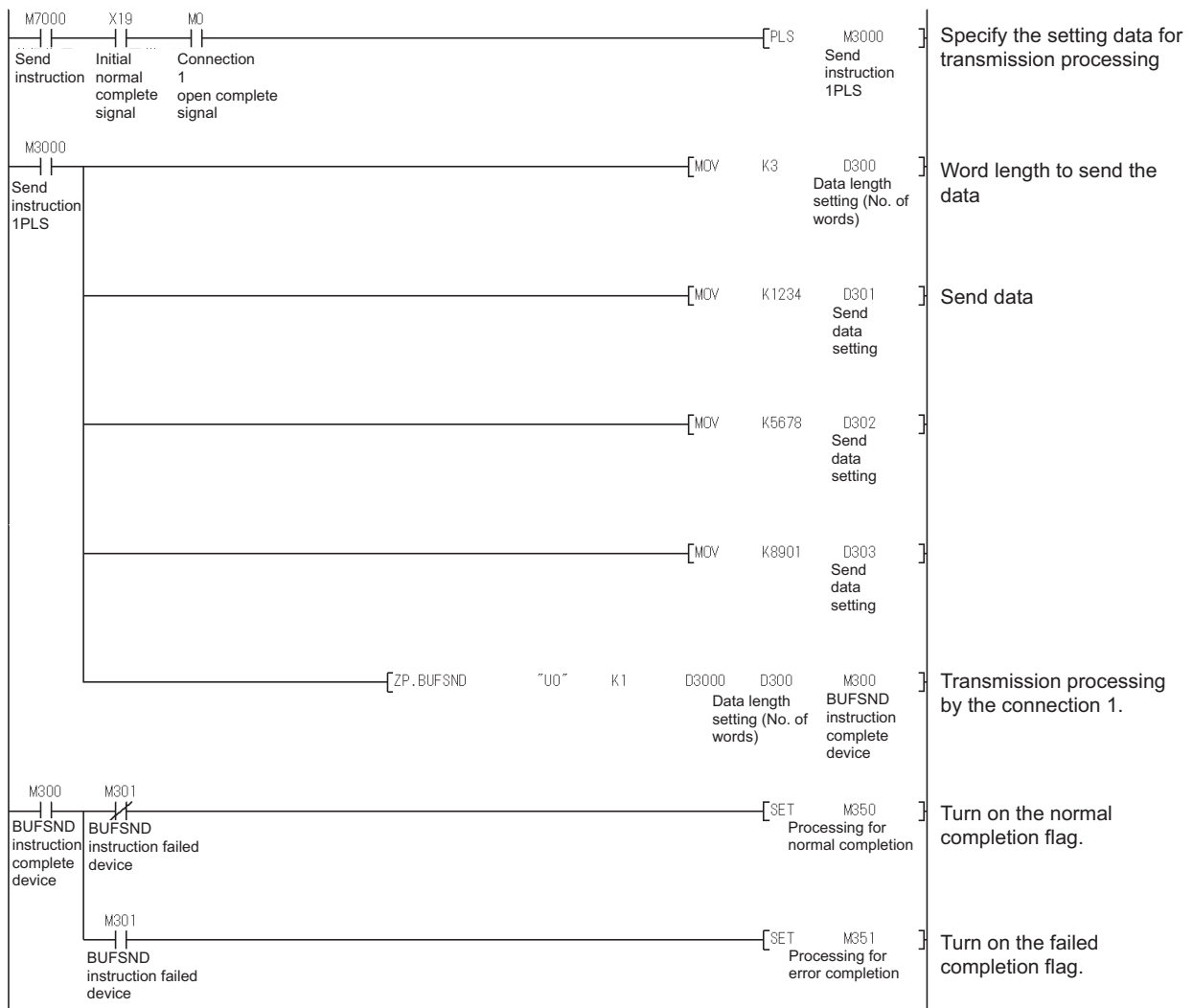

APPENDICES

Appendix 1 External Dimensions

For external dimensions of modules shown in this handbook, refer to the user's manual for each module.

Appendix 2 Spare Parts Storage

- (1) The general specifications of programmable controllers are as follows. Please do not store
- (2) The general specifications of programmable controllers are as follows. Please do not store spare parts under a high temperature or high humidity condition, even within the range guaranteed by the specifications.

Storage ambient temperature	-20 to 75°C
Storage ambient humidity	10 to 90%, no condensation

- (3) Store in a place avoiding direct sunlight.
- (4) Store under condition with less dust or no corrosive gas.
- (5) The battery capacity of an A6BAT or A8BAT battery or a lithium-coin battery (commercially available) for memory card will be decreased by its self-discharging even when not used. Replace it with a new one in 5 years as a guideline.
- (6) For a power supply module, CPU module with built-in power supply, or analog module that use any aluminum electrolytic capacitor, which is indicated in the table below, take the following measures since the characteristics will be deteriorated when the aluminum electrolytic capacitor is left un-energized for a long time.

Product	Model
CPU module (Power supply built-in type)	A1SJHCPU
Power supply module	A1S61PN, A1S62PN, A1S63P
Analog module	A1S64AD, A1S68AD, A1S62DA, A1S68DAI, A1S68DAV, A1S63ADA, A1S66ADA

[Countermeasures for preventing aluminum electrolytic capacitor characteristics deterioration]
Apply the rated voltage to the aluminum electrolytic capacitor for several hours once a year to activate it.
Or, rotate products at the periodic inspection (in every 1 year or two).

[Reference]

The life of an aluminum electrolytic capacitor, even if not used, under a normal temperature decreases approximately at 1/4 speed of the case when it is energized.

Appendix 3 Relevant Manuals

Appendix 3.1 Replacement handbooks

(1) Transition guides

No.	Manual name	Manual number	Transition target	
			A (large)	AnS (small)
1	MELSEC-A/QnA Series Transition Guide	L-08077E	○	×
2	MELSEC-AnS/QnAS (Small Type) Series Transition Guide	L08236E	×	○

(2) Transition handbooks

No.	Manual name	Manual number	Transition target	
			A (large)	AnS (small)
1	Transition from MELSEC-A/QnA (Large Type) Series to Q Series Handbook (Fundamentals)	L-08043ENG	○	×
	Transition from MELSEC-AnS/QnAS (Small Type) Series to Q Series Handbook (Fundamentals)	L-080219ENG	×	○
	Transition from MELSEC-AnS/QnAS (Small Type) Series to L Series Handbook (Fundamentals)	L08258ENG	×	○
2	Transition from MELSEC-A/QnA (Large Type) Series to Q Series Handbook (Intelligent Function Modules)	L-08046ENG	○	×
	Transition from MELSEC-AnS/QnAS (Small Type) Series to Q Series Handbook (Intelligent Function Modules)	L-08220ENG	×	○
	Transition from MELSEC-AnS/QnAS (Small Type) Series to L Series Handbook (Intelligent Function Modules)	L08259ENG	×	○
3	Transition from MELSEC-A/QnA (Large Type), AnS/QnAS (Small Type) Series to Q Series Handbook (Network Modules)	L-08048ENG	○	○
	Transition from MELSEC-AnS/QnAS (Small Type) Series to L Series Handbook (Network Modules)	L08260ENG	×	○
4	Transition from MELSEC-A/QnA (Large Type), AnS/QnAS (Small Type) Series to Q Series Handbook (Communications)	L-08050ENG	○	○
	Transition from MELSEC-AnS/QnAS (Small Type) Series to L Series Handbook (Communications)	L08261ENG	×	○
5	Transition from MELSEC-A0J2H Series to Q Series Handbook	L-08060ENG	○	○
6	Transition from MELSECNET/MINI-S3, A2C(I/O) to CC-Link Handbook	L-08061ENG	○	○
7	Transition from MELSEC-I/OLINK to CC-Link/LT Handbook	L-08062ENG	○	○
8	Transition of CPUs in MELSEC Redundant System Handbook (Transition from Q4ARCPU to QnPRHCPU)	L-08117ENG	○	×

(3) Transition examples manual

No.	Manual name	Manual number	Transition target	
			A (large)	AnS (small)
1	MELSEC-A/QnA Series Transition Examples	L-08121E	○	○

(4) Others

No.	Manual name	Manual number	Transition target	
			A (large)	AnS (small)
1	Procedures for Replacing Positioning Module AD71 with QD75	FA-A-0060	○	○
2	Precautions for replacing A/QnA (large type) series CPU with Universal model QCPU	FA-A-0068	○	×

Appendix 3.2 A series

No.	Manual name	Manual number	Model code
1	For A Ethernet Interface Module User's Manual	SH-080192	13JR45

Appendix 3.3 AnS series

No.	Manual name	Manual number	Model code
1	Computer Link Module Guidebook	SH-3510	13JE76
2	Computer Link Module (Com. link func./Print. func.) User's Manual	SH-3511	13JE77
3	Computer Link Module (Multidrop function) User's Manual	BCN-P5677	-
4	Type A1SD51S Intelligent communication module User's Manual	IB-66551	13JE90
5	AD51H-BASIC Programming Manual (Command)	SH-080090	13JF63
6	AD51H-BASIC Programming Manual (Debug and Compile)	SH-080091	13JF64

Appendix 3.4 QnAS series

No.	Manual name	Manual number	Model code
1	Computer Link Module Guidebook	SH-3510	13JE76
2	Serial Communications Module User's Manual (Modem Function Additional Version)	IB-66612	13J825
3	For QnA Ethernet Interface Module User's Manual	SH-080146	13JR33

Appendix 3.5 L series

No.	Manual name	Manual number	Model code
1	MELSEC-L Serial Communication Module User's Manual (Basic)	SH-080894ENG	13JZ40
2	MELSEC-Q/L Serial Communication Module User's Manual (Application)	SH-080007	13JL87
3	MELSEC-Q/L MELSEC Communication Protocol Reference Manual	SH-080008	13JF89
4	MELSEC-L Ethernet Interface Module User's Manual (Basic)	SH-081105ENG	13JZ73
5	MELSEC-Q/L Ethernet Interface Module User's Manual (Application)	SH-080010	13JL89
6	MELSEC-Q/L Ethernet Interface Module User's Manual (Web function)	SH-080180	13JR40

WARRANTY

Please confirm the following product warranty details before using this product.

1. Gratis Warranty Term and Gratis Warranty Range

If any faults or defects (hereinafter "Failure") found to be the responsibility of Mitsubishi occurs during use of the product within the gratis warranty term, the product shall be repaired at no cost via the sales representative or Mitsubishi Service Company.

However, if repairs are required onsite at domestic or overseas location, expenses to send an engineer will be solely at the customer's discretion. Mitsubishi shall not be held responsible for any re-commissioning, maintenance, or testing on-site that involves replacement of the failed module.

[Gratis Warranty Term]

The gratis warranty term of the product shall be for one year after the date of purchase or delivery to a designated place.

Note that after manufacture and shipment from Mitsubishi, the maximum distribution period shall be six (6) months, and the longest gratis warranty term after manufacturing shall be eighteen (18) months. The gratis warranty term of repair parts shall not exceed the gratis warranty term before repairs.

[Gratis Warranty Range]

- (1) The range shall be limited to normal use within the usage state, usage methods and usage environment, etc., which follow the conditions and precautions, etc., given in the instruction manual, user's manual and caution labels on the product.
- (2) Even within the gratis warranty term, repairs shall be charged for in the following cases.
 1. Failure occurring from inappropriate storage or handling, carelessness or negligence by the user. Failure caused by the user's hardware or software design.
 2. Failure caused by unapproved modifications, etc., to the product by the user.
 3. When the Mitsubishi product is assembled into a user's device, Failure that could have been avoided if functions or structures, judged as necessary in the legal safety measures the user's device is subject to or as necessary by industry standards, had been provided.
 4. Failure that could have been avoided if consumable parts (battery, backlight, fuse, etc.) designated in the instruction manual had been correctly serviced or replaced.
 5. Failure caused by external irresistible forces such as fires or abnormal voltages, and Failure caused by force majeure such as earthquakes, lightning, wind and water damage.
 6. Failure caused by reasons unpredictable by scientific technology standards at time of shipment from Mitsubishi.
 7. Any other failure found not to be the responsibility of Mitsubishi or that admitted not to be so by the user.

2. Onerous repair term after discontinuation of production

- (1) Mitsubishi shall accept onerous product repairs for seven (7) years after production of the product is discontinued.

Discontinuation of production shall be notified with Mitsubishi Technical Bulletins, etc.
- (2) Product supply (including repair parts) is not available after production is discontinued.

3. Overseas service

Overseas, repairs shall be accepted by Mitsubishi's local overseas FA Center. Note that the repair conditions at each FA Center may differ.

4. Exclusion of loss in opportunity and secondary loss from warranty liability

Regardless of the gratis warranty term, Mitsubishi shall not be liable for compensation of damages caused by any cause found not to be the responsibility of Mitsubishi, loss in opportunity, lost profits incurred to the user by Failures of Mitsubishi products, special damages and secondary damages whether foreseeable or not, compensation for accidents, and compensation for damages to products other than Mitsubishi products, replacement by the user, maintenance of on-site equipment, start-up test run and other tasks.

5. Changes in product specifications

The specifications given in the catalogs, manuals or technical documents are subject to change without prior notice.

Country/Region	Sales office	Tel/Fax
USA	MITSUBISHI ELECTRIC AUTOMATION, INC. 500 Corporate Woods Parkway, Vernon Hills, IL 60061, U.S.A.	Tel : +1-847-478-2100 Fax : +1-847-478-2253
Mexico	MITSUBISHI ELECTRIC AUTOMATION, INC. Mexico Branch Mariano Escobedo #69, Col. Zona Industrial, Tlalnepantla Edo, C.P.54030, Mexico	Tel : +52-55-3067-7500
Brazil	MITSUBISHI ELECTRIC DO BRASIL COMÉRCIO E SERVIÇOS LTDA. Rua Jussara, 1750-Bloco B Anexo, Jardim Santa Cecilia, CEP 06465-070, Barueri-SP, Brasil	Tel : +55-11-4689-3000 Fax : +55-11-4689-3016
Germany	MITSUBISHI ELECTRIC EUROPE B.V. German Branch Gothaer Strasse 8, D-40880 Ratingen, Germany	Tel : +49-2102-486-0 Fax : +49-2102-486-1120
UK	MITSUBISHI ELECTRIC EUROPE B.V. UK Branch Travellers Lane, Hatfield, Hertfordshire, AL10 8XB, U.K.	Tel : +44-1707-28-8780 Fax : +44-1707-27-8695
Ireland	MITSUBISHI ELECTRIC EUROPE B.V. Irish Branch Westgate Business Park, Ballymount, IRL-Dublin 24, Ireland	Tel : +353-1-4198800 Fax : +353-1-4198890
Italy	MITSUBISHI ELECTRIC EUROPE B.V. Italian Branch Centro Direzionale Colleoni-Palazzo Sirio Viale Colleoni 7, 20864 Agrate Brianza(Milano) Italy	Tel : +39-039-60531 Fax : +39-039-6053-312
Spain	MITSUBISHI ELECTRIC EUROPE, B.V. Spanish Branch Carretera de Rubí, 76-80-Apdo. 420, 08173 Sant Cugat del Vallés (Barcelona), Spain	Tel : +34-935-65-3131 Fax : +34-935-89-1579
France	MITSUBISHI ELECTRIC EUROPE B.V. French Branch 25, Boulevard des Bouvets, F-92741 Nanterre Cedex, France	Tel : +33-1-55-68-55-68 Fax : +33-1-55-68-57-57
Czech Republic	MITSUBISHI ELECTRIC EUROPE B.V. Czech Branch Avenir Business Park, Radlicka 751/113e, 158 00 Praha5, Czech Republic	Tel : +420-251-551-470 Fax : +420-251-551-471
Poland	MITSUBISHI ELECTRIC EUROPE B.V. Polish Branch ul. Krakowska 50, 32-083 Balice, Poland	Tel : +48-12-630-47-00 Fax : +48-12-630-47-01
Sweden	MITSUBISHI ELECTRIC EUROPE B.V. (Scandinavia) Fjeliévågen 8, SE-22736 Lund, Sweden	Tel : +46-8-625-10-00 Fax : +46-46-39-70-18
Russia	MITSUBISHI ELECTRIC EUROPE B.V. Russian Branch St. Petersburg office Piskarevsky pr. 2, bld 2, lit "Sch", BC "Benua", office 720; RU-195027 St. Petersburg, Russia	Tel : +7-812-633-3497 Fax : +7-812-633-3499
Turkey	MITSUBISHI ELECTRIC TURKEY A.Ş Ümraniye Branch Serifali Mahallesi Nutuk Sokak No:5, TR-34775 Umraniye, Istanbul, Turkey	Tel : +90-216-526-3990 Fax : +90-216-526-3995
Dubai	MITSUBISHI ELECTRIC EUROPE B.V. Dubai Branch Dubai Silicon Oasis, P.O.BOX 341241, Dubai, U.A.E.	Tel : +971-4-3724716 Fax : +971-4-3724721
South Africa	ADROIT TECHNOLOGIES 20 Waterford Office Park, 189 Witkoppen Road, Fourways, Johannesburg, South Africa	Tel : +27-11-658-8100 Fax : +27-11-658-8101
China	MITSUBISHI ELECTRIC AUTOMATION (CHINA) LTD. No.1386 Hongqiao Road, Mitsubishi Electric Automation Center, Shanghai, China	Tel : +86-21-2322-3030 Fax : +86-21-2322-3000
Taiwan	SETSUYO ENTERPRISE CO., LTD. 6F, No.105, Wugong 3rd Road, Wugu District, New Taipei City 24889, Taiwan, R.O.C.	Tel : +886-2-2299-2499 Fax : +886-2-2299-2509
Korea	MITSUBISHI ELECTRIC AUTOMATION KOREA CO., LTD. 7F-9F, Gangseo Hangang Xi-tower A, 401, Yangcheon-ro, Gangseo-Gu, Seoul 157-801, Korea	Tel : +82-2-3660-9530 Fax : +82-2-3664-8372
Singapore	MITSUBISHI ELECTRIC ASIA PTE. LTD. 307, Alexandra Road, Mitsubishi Electric Building, Singapore 159943	Tel : +65-6473-2308 Fax : +65-6476-7439
Thailand	MITSUBISHI ELECTRIC FACTORY AUTOMATION (THAILAND) CO., LTD. 12th Floor, SV.City Building, Office Tower 1, No. 896/19 and 20 Rama 3 Road, Kwaeng Bangpongpan, Khet Yannawa, Bangkok 10120, Thailand	Tel : +66-2682-6522 Fax : +66-2682-6020
Vietnam	MITSUBISHI ELECTRIC VIETNAM COMPANY LIMITED Hanoi Branch 6-Floor, Detech Tower, 8 Ton That Thuyet Street, My Dinh 2 Ward, Nam Tu Liem District, Hanoi, Vietnam	Tel : +84-4-3937-8075 Fax : +84-4-3937-8076
Indonesia	PT. MITSUBISHI ELECTRIC INDONESIA Gedung Jaya 11th Floor, JL. MH. Thamrin No.12, Jakarta Pusat 10340, Indonesia	Tel : +62-21-3192-6461 Fax : +62-21-3192-3942
India	MITSUBISHI ELECTRIC INDIA PVT. LTD. Pune Branch Emerald House, EL-3, J Block, M.I.D.C Bhosari, Pune-411026, Maharashtra, India	Tel : +91-20-2710-2000 Fax : +91-20-2710-2100
Australia	MITSUBISHI ELECTRIC AUSTRALIA PTY. LTD. 348 Victoria Road, P.O. Box 11, Rydalmere, N.S.W 2116, Australia	Tel : +61-2-9684-7777 Fax : +61-2-9684-7245

Mitsubishi Electric Corporation Nagoya Works is a factory certified for ISO 14001 (standards for environmental management systems) and ISO 9001 (standards for quality assurance management systems)

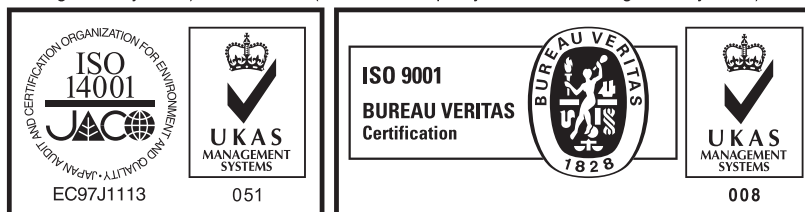

MITSUBISHI ELECTRIC CORPORATION

HEAD OFFICE: TOKYO BUILDING, 2-7-3, MARUNOUCHI, CHIYODA-KU, TOKYO 100-8310, JAPAN
NAGOYA WORKS: 1-14, YADA-MINAMI 5, HIGASHI-KU, NAGOYA, JAPAN